

# **TSUBAKI POWER CYLINDER<sup>®</sup> LINIPOWER JACK<sup>®</sup>**



# Power Cylinder



# Integrated Actuator

# Linipower Jack



## Series lineup

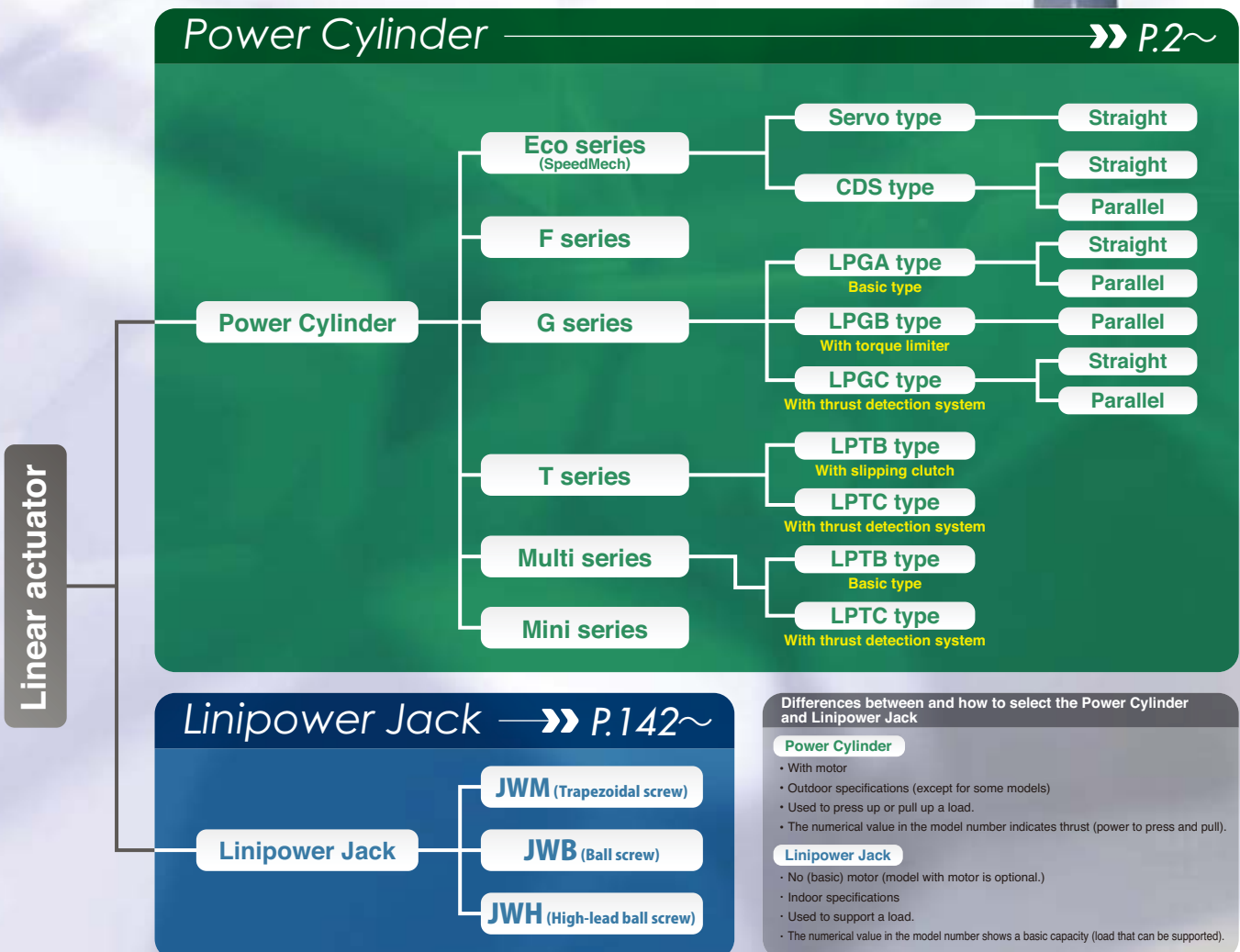





# Power Cylinder

<b>Application</b>	_____	<b>3</b>
<b>Examples of use</b>	_____	<b>5</b>
<b>Basic specifications list</b>	_____	<b>7</b>
<b>Capacity range</b>	_____	<b>9</b>
<b>Eco series</b>	_____	<b>10</b>
<b>F series</b>	_____	<b>52</b>
<b>G series</b>	_____	<b>66</b>
<b>T series</b>	_____	<b>86</b>
<b>Multi series</b>	_____	<b>124</b>
<b>Mini series</b>	_____	<b>134</b>

# Power Cylinder



## APPLICATION SOLUTION

TSUBAKI E&M Power Cylinders were born over 40 years ago, and have been used across a variety of industries by a wide range of customers.

By taking advantage of our accumulated experience, we have continued to develop new products as well as upgrade technologies, and proactively address environmental issues to create our present series.

We will continue to create products which are customer-friendly, taking the environment into consideration.

For pusher/roller conveyor

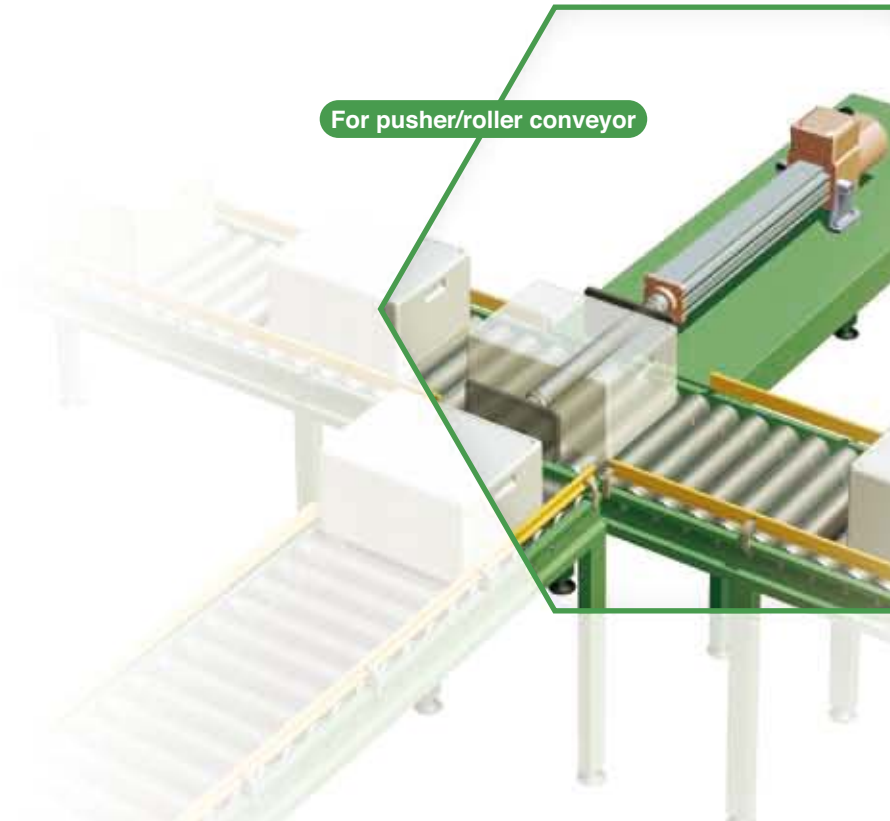



For heat treatment furnace/door opening and closing

LCD TVs



For lifters/pin insertion to fix

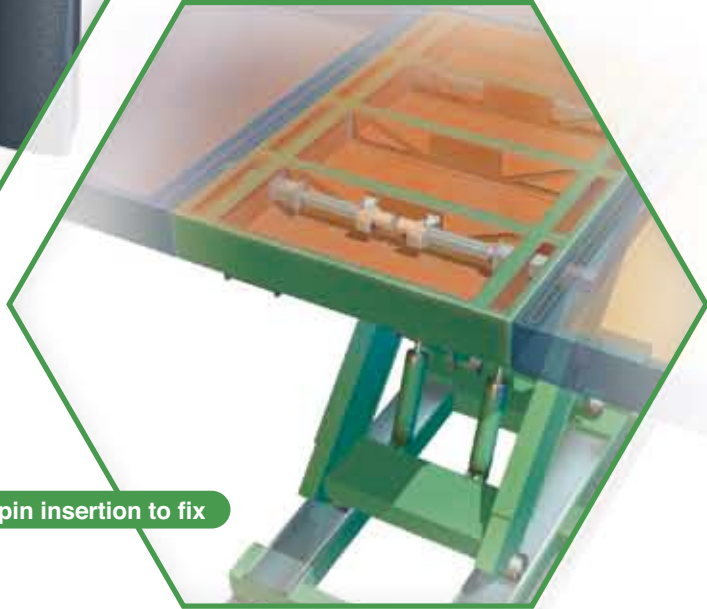

For CT scanning/bed elevation



For machine tools/door opening and closing



# Power Cylinder

## Examples of use

### Opening and closing

Various types of opening and closing can be performed by changing the linear motion of power cylinders into turning force through link mechanisms or by using the linear motion as it is. The G series (GC type) and T series (TC type) that can press at the end are suitable. Those with a position detecting unit are used to indicate the degree of opening.

- Opening and closing of hopper gates
- Opening and closing of switching dampers
- Opening and closing of the lids of drying furnaces, incinerators, various kilns, etc.

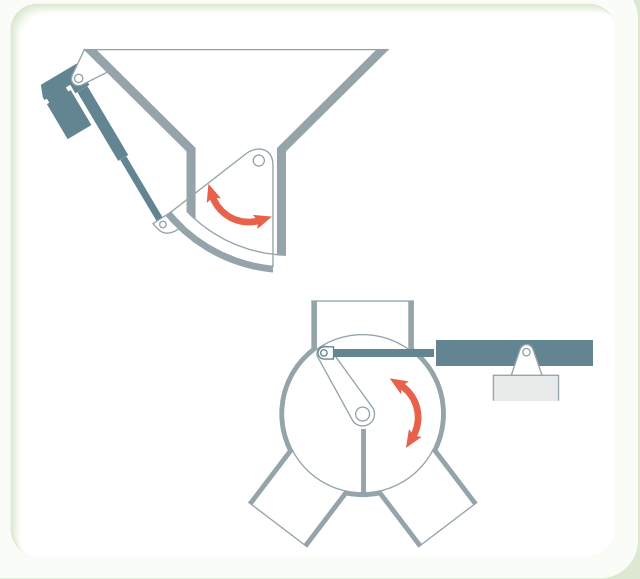

### Elevation

Various types of elevation can be performed by using the linear motion of power cylinders. Power cylinders are effective for holding loads reliably and in synchronization.

- Pantograph type lifting and lowering devices
- Lifting and lowering devices using fixed pulleys and moving pulleys.
- Lifting and lowering devices directly using the linear motion of power cylinders (telescope type)
- Lifting and lowering devices operating multiple power cylinders synchronously

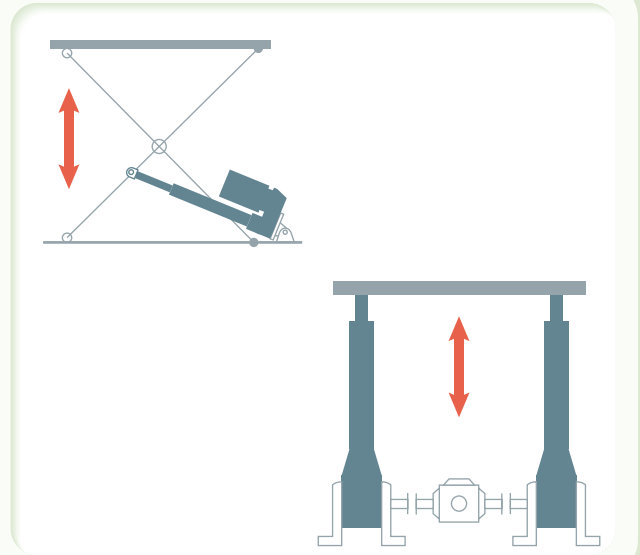

### Turnover

Conveyed objects can be turned over and transferred by the linear motion of power cylinders and simple supporting arrangements. Smooth operation can be performed with little backlash.

- Turnover devices for steel materials and packaged goods
- Lateral turning of wire bobbins
- Turnover of furnaces

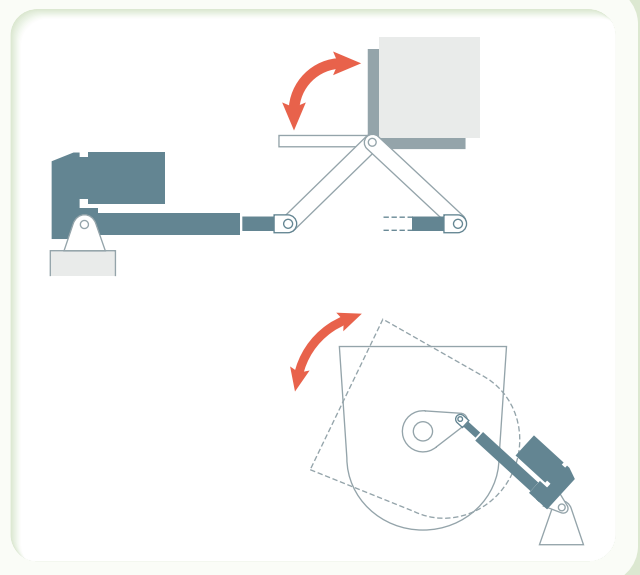

# Handling

Various handling devices can be established by combining power cylinders and link mechanisms. Power cylinders enable reliable fastening.

- Chucking of cotton materials, and chucking and transfer of steel materials
- Handling of various automatic apparatuses

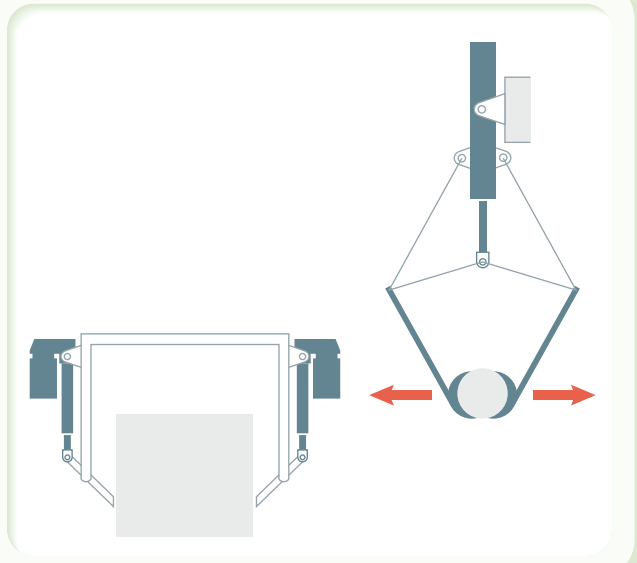

# Stopper

Conveyed objects can be stopped or changed in direction mainly through the link mechanisms in addition to the linear motion of power cylinders. Also, they can be stopped directly by power cylinders.

- Directional adjustments of the flows of conveyed objects on belt conveyors
- Stopper for conveyed objects on roller conveyors
- Stopper for materials in material cutting machines

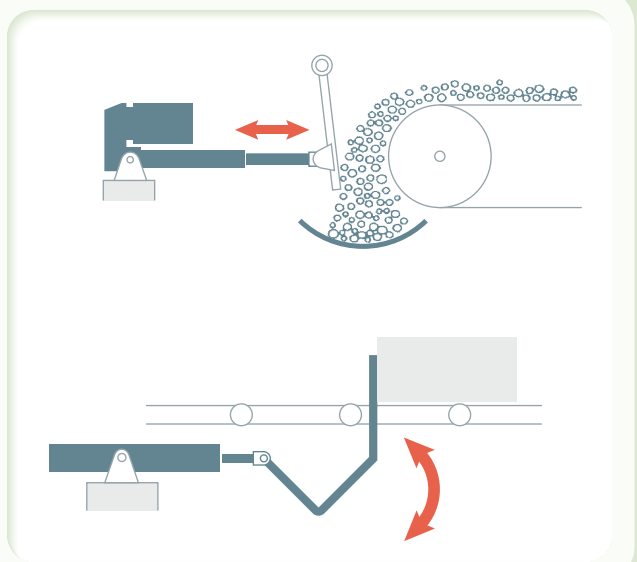

# Positioning

Goods and materials can be moved into place and positioned by using a single or multiple power cylinders. Furthermore, they can be held and fixed in place.

- Positioning of materials, etc., in cutting machines
- Positioning and finishing machines of corrugated cardboard, plated parts, etc.
- Positioning and fixing for taking in and out movable stands in event halls

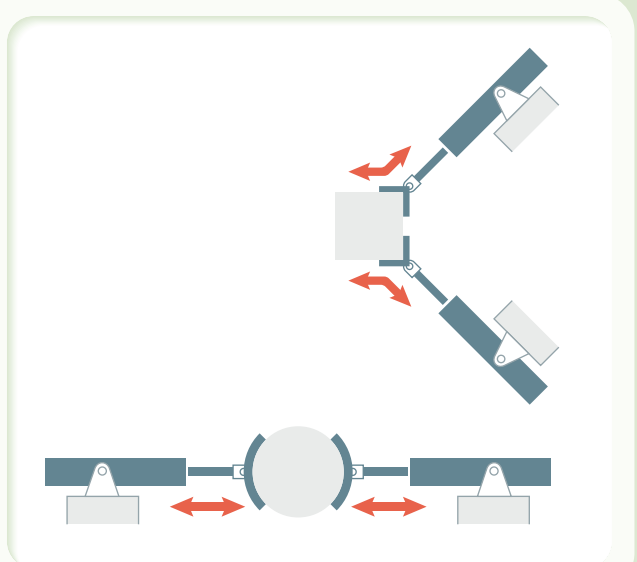



# Power Cylinder

## Power Cylinder Basic specifications list

TSUBAKI E&M Power Cylinders come in a variety of types and options in our 7 series lineup. Select the optimum model and option for your application.

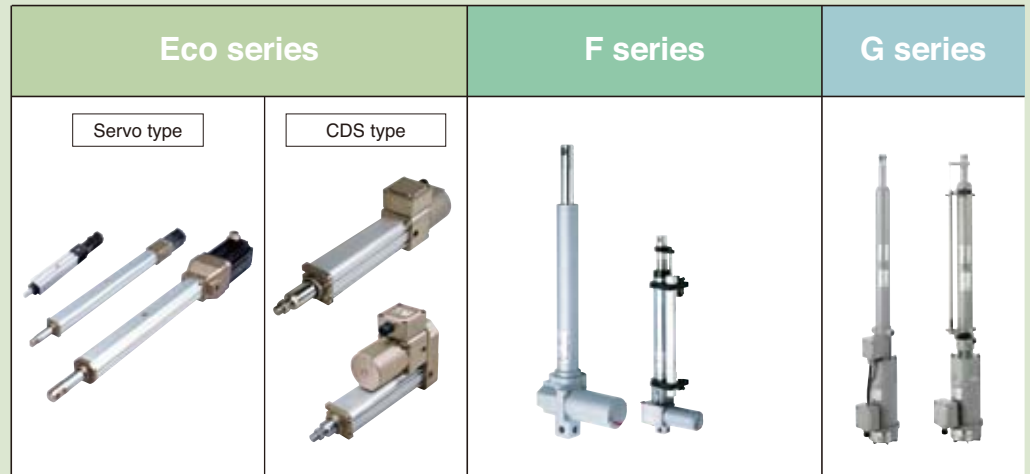

* Rated thrust	N {kgf}	150N~1500N {15.3~1530kgf}					0.25kN~1.00kN {25.5~103kgf}				100N~6.00kN {10.2~612kgf}						700N~3.00kN {71.4~306kgf}					
		15.3	30.6	153	306	1530	25.5	51.0	51.0	102	10.2	20.4	40.8	102	204	306	612	70	100	150	300	
Speed	Slow																					
	Low											15			9	8		25/30	25/30	25/30	25/30	
	Medium							90/100	90/90		24			18				75/90	75/90	75/90	50/60	
	High			~300		~333	160/190		160/170		54			30				100/120 200/240	100/120 200/240	100/120	67/80	
Stroke	2000mm																					
	1500mm																					
	1200mm																	●	●	●	●	
	1000mm					●												●	●	●	●	
	800mm					●												●	●	●	●	
	600mm			●	●	●	●	●	●	●							●	●	●	●	●	
	500mm			●	●	●	●	●	●	●							●	●	●	●	●	
	400mm			●	●	●	●	●	●	●							●	●	●	●	●	
	300mm	●	●	●	●	●	●	●	●	●	●	●	●	●	●	●	●	●	●	●	●	●
	200mm	●	●	●	●	●	●	●	●	●	●	●	●	●	●	●	●	●	●	●	●	●
	100mm	●	●	●	●		●	●	●	●	●	●	●	●	●	●	●	●	●	●	●	●
	50mm										●	●	●	●	●	●						

\* Thrust means force at which the power cylinder can press and pull.

\* For Eco series servo type, this row is the maximum thrust instead.

### Options

With brake									●												●
With shaft for manual operation									●												●
Anti-rod rotation	○								○												○
With external limit switch for stroke adjustment														○							○
With internal limit switch for positioning detection*														○							○
With potentiometer*														○							○
With rotary encoder*														○							○
With bellows				○					○												○
Clevis fitting													●								○
Trunnion fitting	○			○					○												○
Foot fitting	○																				
I-type end fitting	●			●					○												○
U-type end fitting	○			○					○												●
N-type end fitting	○								●												

\* For options with an \* mark, the clevis fitting cannot be attached.

Note) ● indicates standard. ○ indicates an option.



# Power Cylinder

## Power Cylinder capacity range

TSUBAKI E&M Power Cylinders can be used across a wide range of thrusts and speeds.

Refer to the image diagram below and select the optimum model from the basic specifications list on pages 7 and 8.

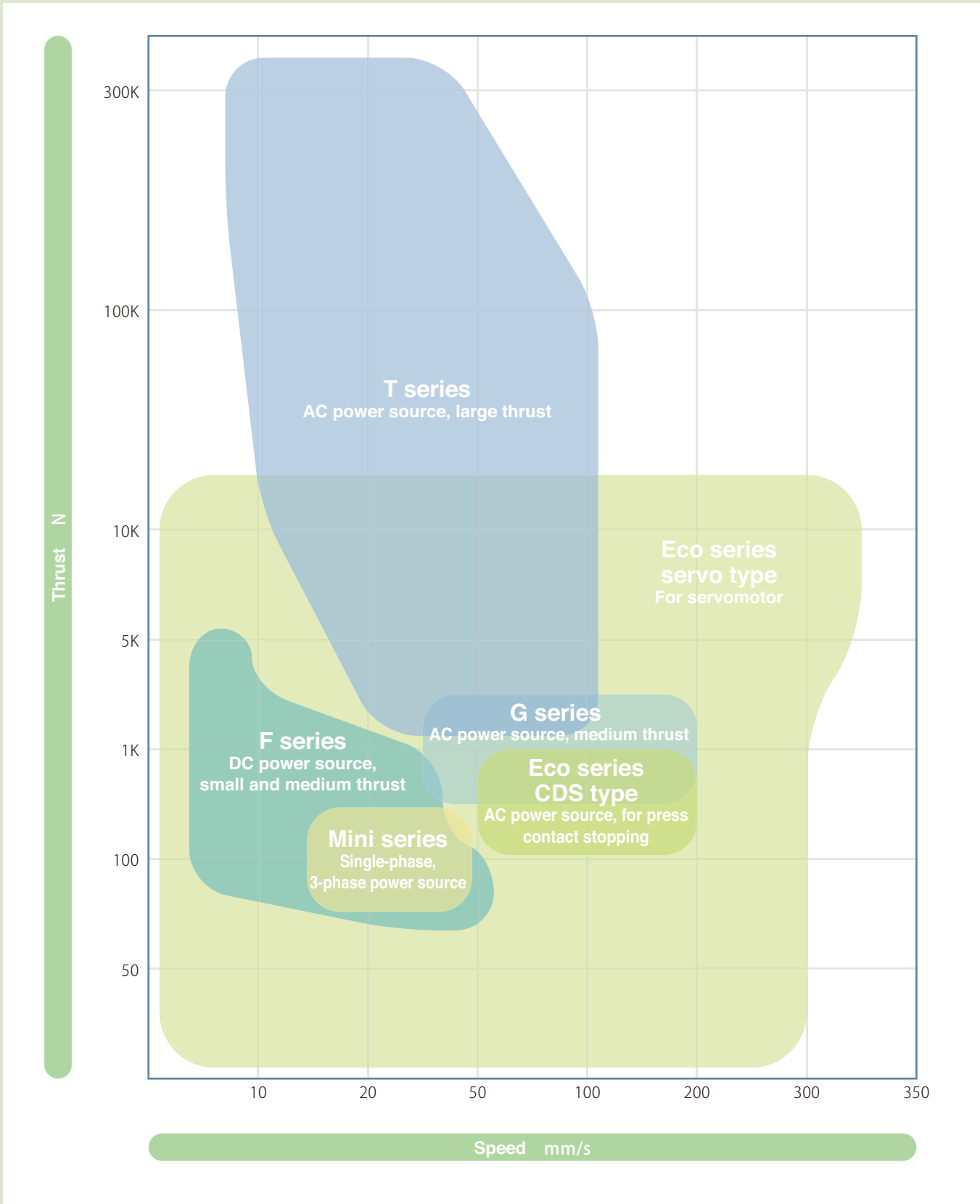



Power Cylinder

# Eco series

## Eco series servo type

Thrust : 150N to 1500N {15.3kgf to 1530kgf}

- Maximization of servomotor performance
- Realization of high stopping accuracy
- Selectable servomotor
- Realization of high speeds and wide-ranging thrusts
- Reduction in servomotor capacity with precision planetary reducer

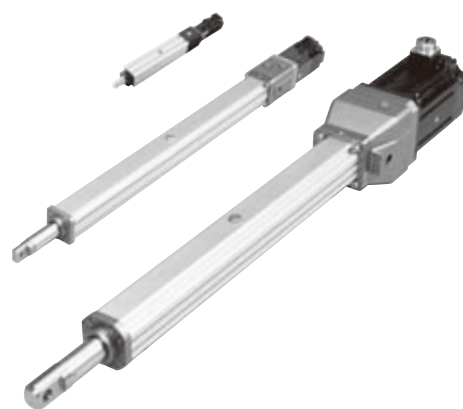

## Eco series CDS type

Thrust : 250N to 1.00kN {25.5kgf to 102kgf}

- Self-contained
- Environmentally friendly
- Running cost reduction
- For highly frequent operation and long life
- Simple operation

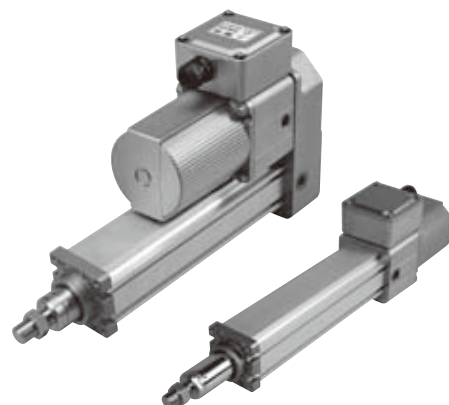

# Power Cylinder Eco Series

New lineup for mount coding and with precision planetary reducer

## Mount coding

Selection of each company's servomotors is facilitated.

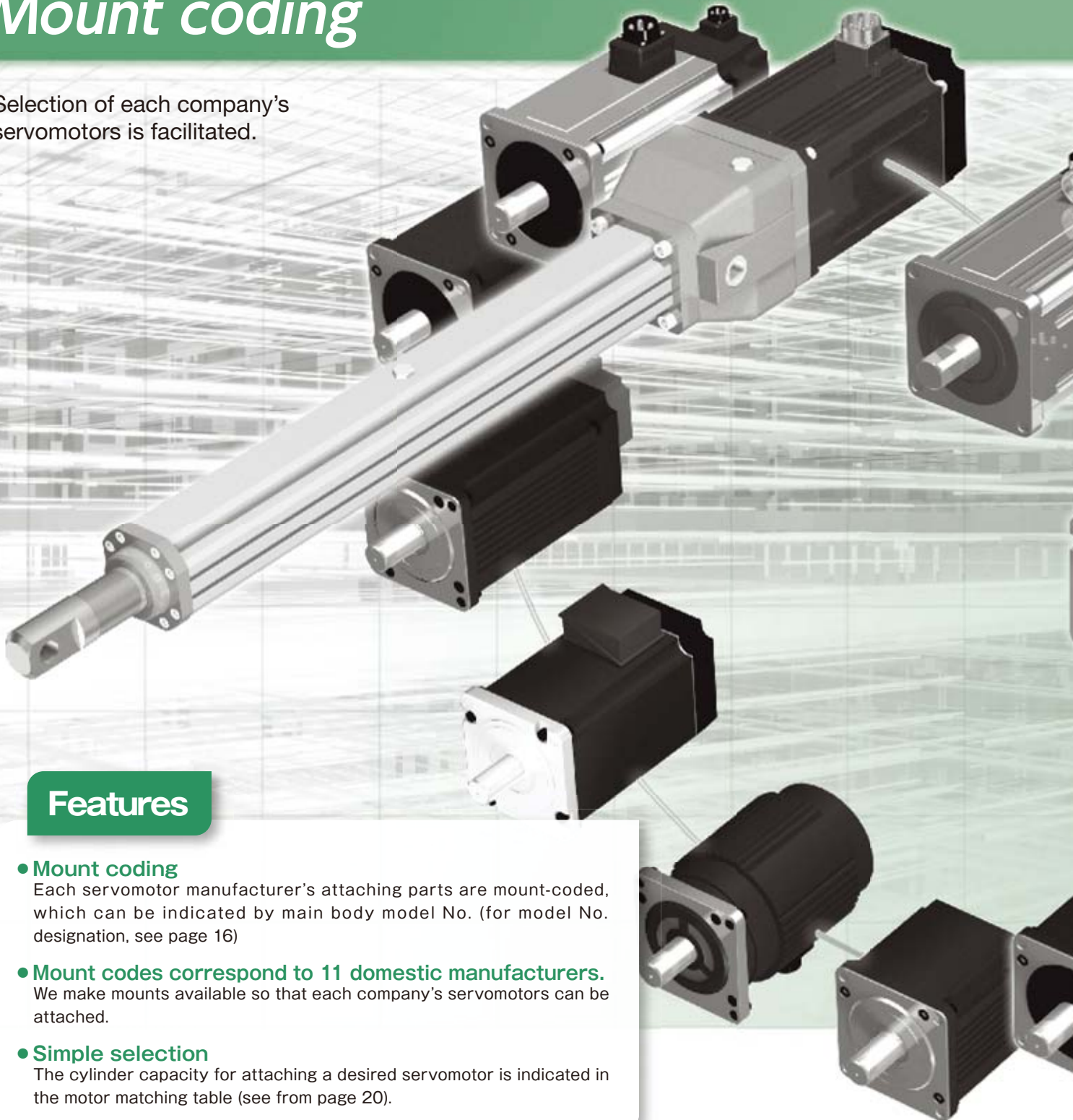

### Features

- **Mount coding**

Each servomotor manufacturer's attaching parts are mount-coded, which can be indicated by main body model No. (for model No. designation, see page 16)

- **Mount codes correspond to 11 domestic manufacturers.**

We make mounts available so that each company's servomotors can be attached.

- **Simple selection**

The cylinder capacity for attaching a desired servomotor is indicated in the motor matching table (see from page 20).

# Servo Type

Expanded  
model

## With precision planetary reducer

For low-speed uses, the motor capacity can be reduced in combination with our precision planetary reducer PAT-B.

Size reduction



Smart coupling housing

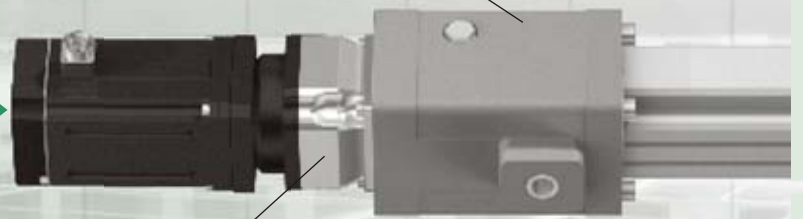

Precision planetary reducer

### Features

- **Equipment cost reduction**

As the servomotor capacity becomes smaller, the amplifier (driver) also becomes smaller, so that the initial cost can be reduced.

- **Light weight and compactness**

Due to the reduction in servomotor size, a new smart coupling housing is adopted. Mass reduction is up to approximately 30kg (80%).

- **High-precision positioning**

Due to the adoption of our precision planetary reducer (PAT-B), the backlash of the reducer will not affect the cylinder accuracy.





# Guidance for selection

Power cylinder eco series is available in servo type and CDS type for various uses. Select optimum cylinders according to your use and operating conditions (thrust, speed, stroke, accuracy, expected life, etc.)

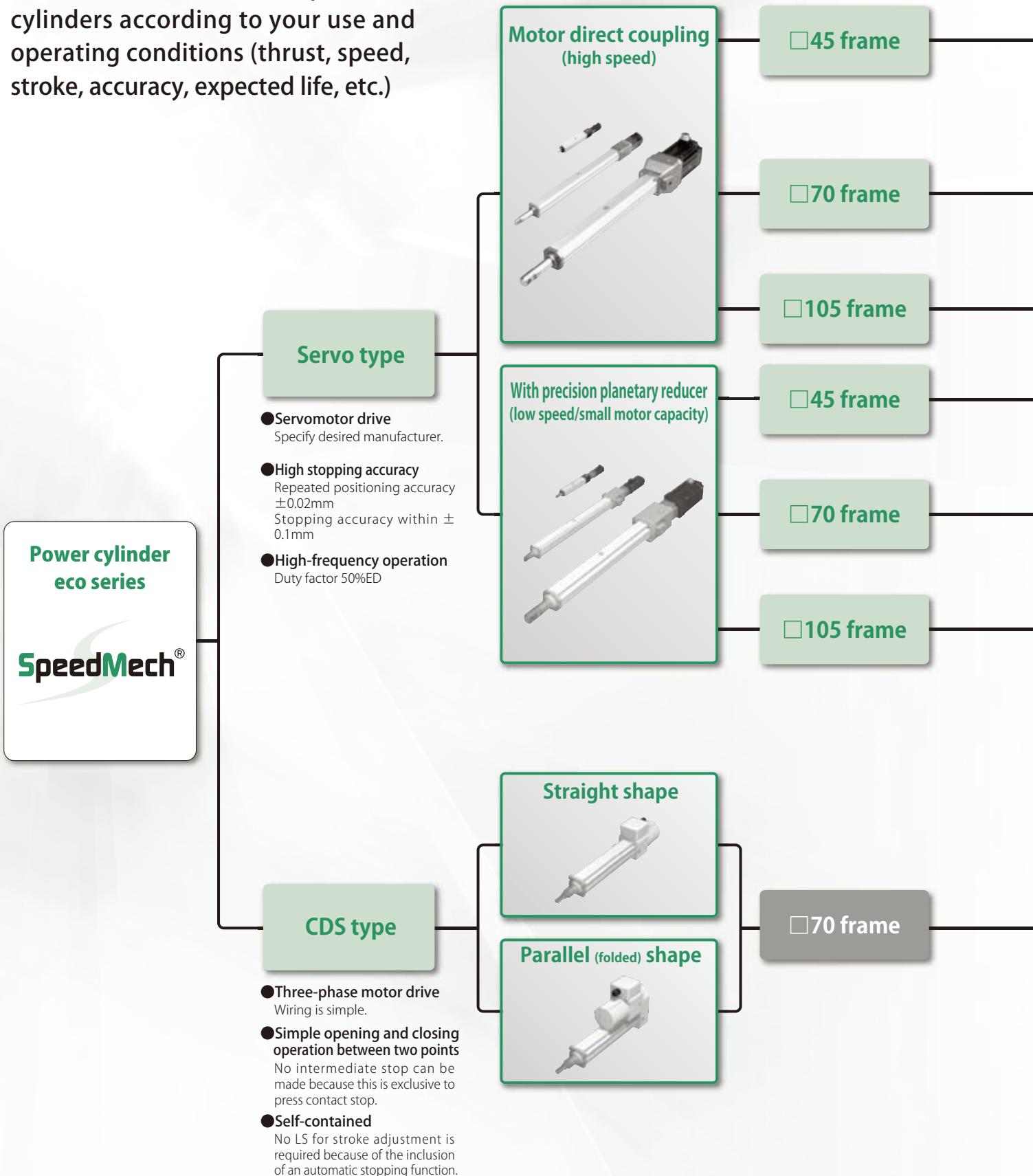

## Servomotor manufacturers

**Mitsubishi Electric** → P.20    **Yaskawa Electric** → P.21    **Panasonic** → P.22    **Fuji Electric** → P.23  
**Omron** → P.24    **Sanyo Denki** → P.25    **FANUC** → P.26    **Keyence** → P.27  
**Nikki Denso** → P.28    **Tamagawa Seiki** → P.29    **Hitachi Industrial Equipment Systems** → P.30

	Allowable thrust	Maximum speed	Motor capacity range	Maximum stroke			
LPES15F	150N {15.3kgf}	300mm/s	0.05~0.1kW	300mm	Model No. indication  → P.16	Dimensions table → P.31	
LPES30F	300N {30.6kgf}	300mm/s	0.1~0.35kW	300mm			
LPES150F	1500N {153kgf}	300mm/s	0.55~0.75kW	600mm			
LPES300F	3000N {306kgf}	300mm/s	0.3~2kW	600mm			
LPES1500F	15000N {1530kgf}	333mm/s	0.85~11kW	1000mm			
LPES30R	300N {30.6kgf}	100mm/s	0.03~0.2kW	300mm			Dimensions table → P.32
LPES150R	1500N {153kgf}	100mm/s	0.1~0.5kW	600mm			Dimensions table → P.34
LPES300R	3000N {306kgf}	100mm/s	0.13~1.5kW	600mm			
LPES1500R	15000N {1530kgf}	167mm/s	0.3~5.5kW	1000mm			Dimensions table → P.36

	Thrust generated	Rated speed	Motor output	Maximum stroke		
LPE025H	250N {25.5kgf}	160/190/200 mm/s	0.25N·m (50W or equivalent)	600mm	Model No. indication  → P.44	Dimensions table → P.45
LPE050L	500N {51.0kgf}	90/100/110 mm/s	0.25N·m (50W or equivalent)	600mm		
LPE050H	500N {51.0kgf}	160/170/190 mm/s	0.50N·m (90W or equivalent)	600mm		
LPE100L	1000N {102gf}	90/90/110 mm/s	0.50N·m (90W or equivalent)	600mm		

# New models of power cylinders capable of corresponding to wide-ranging speeds and thrusts



### Maximization of servomotor performance

Servomotor performance is maximized by combining high-efficiency ball screw and high-rigidity and light-weight disc coupling. Because of clamp type fastening, there is no backlash like key fastening. Clamp type fastening also applies even with precision planetary reducer.

### Realization of high stopping accuracy

High stopping accuracy is realized through the adoption of high-precision ball screw. The repeated positioning accuracy\*1 is  $\pm 0.02\text{mm}$ . The stopping accuracy\*2 is within  $\pm 0.1\text{mm}$ . The accuracies are not affected even with the precision planetary reducer.

\*1) Difference in the position of stopping at one point in the same direction of operation

\*2) Difference between target point and actual stopping position

### Effects with precision planetary reducer

Due to the reduction in servomotor size, the following effects can be expected:

- Peripheral equipment, such as amplifier, can also be made smaller, so that the initial cost can be reduced.
- Electric energy decreases, so that the running cost can also be reduced.
- The coupling housing is also down-sized to be lightweight and compact.

### Selectable servomotor

A desired servomotor can be installed. For an estimate, inform us of the servomotor manufacturer or mount code. Also, specify Ⓢ Motor handling in model No. designation.

Note) Each manufacturer has some unsupported models.

### Realization of high speeds and wide-ranging thrusts

Can be used at high speeds in a large thrust area.

- 45 frame 300mm/s at the maximum thrust of 300N {30.6kgf}
- 70 frame 300mm/s at the maximum thrust of 3000N {306kgf}
- 105 frame 333mm/s at the maximum thrust of 15000N {1530kgf}

**Model No. designation**

① **LPES** ② **1500** ③ **R** ④ **5** ⑤ **T** ⑥ **10** ⑦ **G5L** ⑧ **A** ⑨ **SUJ**

**① Product/series name**

Power cylinder  
eco series servo type

**② Allowable thrust**

<input type="checkbox"/> 45 frame	15 :	150N	{15.3kgf}
	30 :	300N	{30.6kgf}
<input type="checkbox"/> 70 frame	150 :	1500N	{153kgf}
	300 :	3000N	{306kgf}
<input type="checkbox"/> 105 frame	1500 :	15000N	{1530kgf}

**③ Motor mounting method**

F: Motor direct coupling (no reduction gear ratio)  
R: With precision planetary reducer

\* For details, see the motor matching table (from page 20).

**④ Reduction gear ratio**

3 : 1 / 3  
4 : 1 / 4  
5 : 1 / 5  
7 : 1 / 7  
9 : 1 / 9  
A : 1 / 10

**⑤ Main body shape**

T: straight

**⑥ Stroke**

3 : 300mm  
10 : 1000mm

\* The above numerical values are examples.  
For actual strokes, see the standard model list below.

**⑧ Motor handling**

A: Installed by customer  
B: Supplied by customer

**⑦ Mount code**

G5L: Example) 750W manufactured by Mitsubishi Electric  
\* For details, see the motor matching table (from page 20).

**⑨ Options**

W: Waterproof spec IP65 (70 and 105 frames only)  
M: Anti-rod rotation spec (45 frame only)  
S: With 3 magnetic sensors  
(See the sensor related option on page 17.)  
U: U-type end fitting  
N: N-type end fitting (45 frame only)  
(No symbol indicates I-type end fitting.)  
J: Bellows (70 and 105 frames only)  
(The strokes do not change even with bellows.)

**Standard model list**

Model No.	Reduction gear ratio	Allowable thrust N {kgf}	Speed mm/s	Stroke mm	Screw diameter mm	Screw lead mm	Frame size
LPES15F	-	150 {15.3}	300	100 200 300	Φ12	6	<input type="checkbox"/> 45
LPES30F	-	300 {30.6}	300				
LPES30R3	3		100				
LPES30R4	4		75				
LPES30R5	5		60				
LPES30R7	7		43				
LPES30R9	9		33				
LPES30RA	10		30				
LPES150F	-	1500 {153}	300	100 200 300 400 500 600	Φ20	6	<input type="checkbox"/> 70
LPES150R3	3		100				
LPES150R4	4		75				
LPES150R5	5		60				
LPES150R7	7		43				
LPES150R9	9		33				
LPES150RA	10		30				
LPES300F	-	3000 {306}	300	100 200 300 400 500 600	Φ20	6	<input type="checkbox"/> 70
LPES300R3	3		100				
LPES300R4	4		75				
LPES300R5	5		60				
LPES300R7	7		43				
LPES300R9	9		33				
LPES300RA	10		30				
LPES1500F	-	15000 {1530}	333	200 300 400 500 600 800 1000	Φ30	10	<input type="checkbox"/> 105
LPES1500R3	3		167				
LPES1500R4	4		125				
LPES1500R5	5		100				
LPES1500R7	7		71				
LPES1500R9	9		56				
LPES1500RA	10		50				

\* The speeds are values at an input of 3000r/min (except for LPES1500F, the speed of which is a value at an input of 2000r/min).

**Standard use environment**

Model Environment	Indoor type
Ambient temperature	0~40℃
Relative humidity	85% or less (non-condensing)
Impact resistance value	1G or less
Installation altitude	1000m or lower above sea level
Atmosphere	Normally indoors*

\* "Normally indoors" means no exposure to wind, rain and water, and at a general in-factory level of dust.



## Structure

### 45 frame

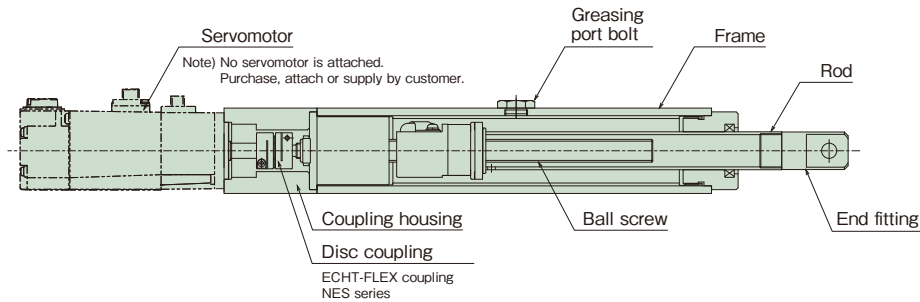

### 70 • 105 frame

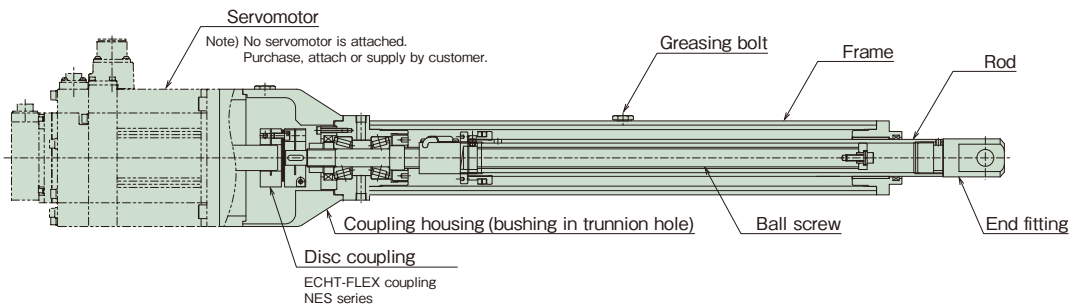

#### Driving part

**Motor**  
A servomotor of almost any manufacturer can be selected. Please attach or supply a servomotor.

#### Coupling part

**Coupling**  
ECHT-FLEX coupling NES series is adopted. The industry leader in light weight and high rigidity, servomotor functions are fully exerted.

#### Actuating part

**Ball screw**  
Highly efficient ball screw is adopted. It can withstand remarkably frequent operations and a long life can be expected.

**Frame**  
To realize lighter weight, an aluminum frame has been adopted. And the external dimensions of the cylinder are not changed even after mounting a magnetic sensor.

## Sensor related option

### Standard magnetic sensor (S)

#### 45 frame

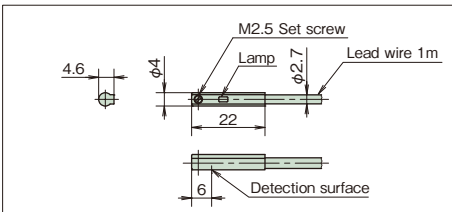

#### Electric circuit

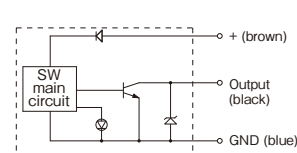

#### Magnetic sensor specifications

Non-contact switch (DC 3-wire system, lead wire 1m, with lamp)	
Power voltage	5~24V DC
Consumption current	10mA or less
Load current	40mA or less
Output specifications	Open collector output

#### 70 • 105 frame

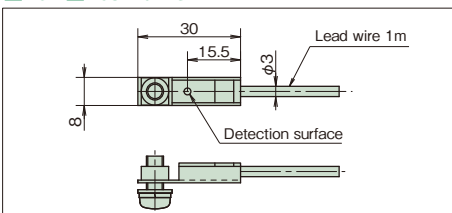

#### Electric circuit

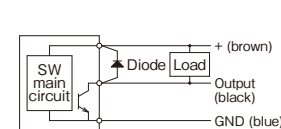

#### Magnetic sensor specifications

Non-contact switch (DC 3-wire system, lead wire 1m)	
Power voltage	5~26V DC
Consumption current	8mA MAX (24V DC)
Output specifications	15mA MAX (24V DC) Open collector output

### Special type (for 70 and 105 frames)

#### ① With (LED) lamp

When the sensor detects, a red lamp lights to indicate detection. It is useful when setting the position of the magnetic sensor.

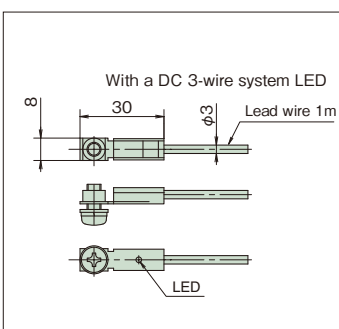

#### Electric circuit

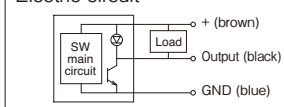

#### Magnetic sensor specifications

For position detection	
Power voltage	5~24V DC
Consumption current	8mA MAX (24V DC)
Output specifications	15mA MAX (24V DC) Open collector output

#### ② 2-wire system

\* 2-wire system is only with lamp.

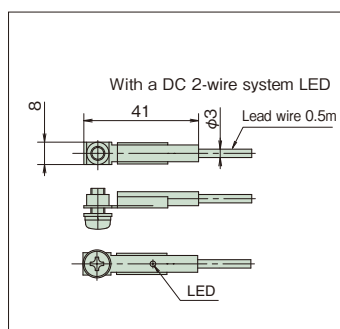

#### Electric circuit

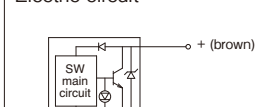

#### Magnetic sensor specifications

For position detection	
Power voltage	10~28V DC
Load current	5~40mA
Internal drop voltage	4V or less

## Input shaft conversion inertia moment

Model No.	Reducer frame No.	Inertia moment X10 <sup>-4</sup> kg·m <sup>2</sup>					
		100	200	300	400	500	600
LPES15F	-	0.086	0.102	0.119	-	-	-
LPES30F	-	0.134	0.151	0.168	-	-	-
LPES30R3	120	0.045	0.047	0.049	-	-	-
LPES30R4		0.038	0.039	0.041	-	-	-
LPES30R5		0.035	0.036	0.037	-	-	-
LPES30R7		0.033	0.033	0.033	-	-	-
LPES30R9		0.032	0.032	0.032	-	-	-
LPES30RA		0.031	0.032	0.032	-	-	-
LPES150F		-	1.039	1.166	1.292	1.418	1.545
LPES150R3	160	0.275	0.290	0.304	0.318	0.332	0.346
LPES150R4		0.205	0.213	0.221	0.229	0.237	0.244
LPES150R5		0.172	0.177	0.182	0.187	0.192	0.197
LPES150R7		0.151	0.154	0.156	0.159	0.162	0.164
LPES150R9		0.143	0.144	0.146	0.148	0.149	0.151
LPES150RA		0.140	0.142	0.143	0.144	0.145	0.147
LPES300F		-	1.720	1.846	1.973	2.099	2.225
LPES300R3	160	0.351	0.365	0.379	0.393	0.407	0.421
LPES300R4		0.247	0.255	0.263	0.271	0.279	0.287
LPES300R5		0.199	0.204	0.209	0.214	0.219	0.224
LPES300R7		0.165	0.168	0.170	0.173	0.175	0.178
LPES300R9		0.151	0.153	0.154	0.156	0.157	0.159
LPES300RA		0.147	0.148	0.150	0.151	0.152	0.154
LPES300R3		220	0.801	0.815	0.829	0.843	0.857
LPES300R4	0.587		0.595	0.603	0.611	0.619	0.627
LPES300R5	0.539		0.544	0.549	0.554	0.559	0.564
LPES300R7	0.485		0.488	0.490	0.493	0.495	0.498
LPES300R9	0.461		0.463	0.464	0.466	0.467	0.469
LPES300RA	0.457		0.458	0.460	0.461	0.462	0.464

Model No.	Reducer frame No.	Inertia moment X10 <sup>-4</sup> kg·m <sup>2</sup>						
		200	300	400	500	600	800	1000
LPES1500F	-	6.913	7.555	8.197	8.838	9.480	10.763	12.047
LPES1500R3	220	2.000	2.072	2.143	2.214	2.286	2.428	2.571
LPES1500R4		1.262	1.302	1.342	1.382	1.423	1.503	1.583
LPES1500R5		0.971	0.996	1.022	1.048	1.073	1.125	1.176
LPES1500R7		0.705	0.718	0.732	0.745	0.758	0.784	0.810
LPES1500R9		0.594	0.602	0.610	0.618	0.626	0.642	0.658
LPES1500RA		0.565	0.572	0.578	0.584	0.591	0.604	0.616
LPES1500F		-	12.513	13.155	13.797	14.438	15.080	16.363
LPES1500R3	320	4.640	4.712	4.783	4.854	4.926	5.068	5.211
LPES1500R4		3.522	3.562	3.602	3.642	3.683	3.763	3.843
LPES1500R5		3.211	3.236	3.262	3.288	3.313	3.365	3.416
LPES1500R7		2.875	2.888	2.902	2.915	2.928	2.954	2.980
LPES1500R9		2.724	2.732	2.740	2.748	2.756	2.772	2.788
LPES1500RA		2.695	2.702	2.708	2.714	2.721	2.734	2.746
LPES1500F		-	16.113	16.755	17.397	18.038	18.680	19.963
LPES1500R3	400	11.000	11.072	11.143	11.214	11.286	11.428	11.571
LPES1500R4		8.547	8.587	8.627	8.667	8.708	8.788	8.868
LPES1500R5		8.065	8.090	8.116	8.142	8.167	8.219	8.270
LPES1500R7		7.469	7.482	7.495	7.508	7.521	7.547	7.574
LPES1500R9		7.239	7.247	7.255	7.263	7.271	7.286	7.302
LPES1500RA		7.191	7.198	7.204	7.210	7.217	7.230	7.242

The moment of inertia does not include the moment of inertia of the servomotor.

## Operating frequency and duty factor

The working time rate shows a rate of operating time per 30 minutes on a 30-minute basis.

The working time rate is calculated with the right formula.

The allowable cycle number of the Eco series servo type is determined depending on heating of the motor and heating of the ball screw and bearing part. It varies depending on the stroke and thrust in use, use the values specified above as a guide. Additionally, the life of the cylinder is not considered for the values.

Number of cycles	15 times/min.
Working time rate	50%ED

$$\text{Working time rate (\%ED)} = \frac{\text{operating time of a cycle}}{\text{operating time of a cycle} + \text{dwell time}} \times 100$$

## Life

The life of the ball screw varies depending on peeling due to fatigue of the rolling surface. Check the approximate life with this expected traveling distance graph. However, when shocks are frequently applied, and when appropriate lubrication or maintenance are not provided, the expected traveling distance becomes considerably shorter.

$$\text{Expected traveling distance (km)} = \text{actual load stroke (m)} \times \text{operation frequency (times/day)} \times \text{operating number of days/year} \times 10^{-3} \times \text{expected number of years}$$

The graph at the right is on an L10 life basis.

The L10 life means the life that can be reached by 90% or more of all is shown as traveling distance.

When selecting a power cylinder based on the life, select the model No. from this graph.

For example, if the expected traveling distance is 1000km and the actual load is 5000N (510kgf), the required power cylinder is LPES1500.

\* Select the servomotor capacity from the motor matching table as the actual load < thrust generated.

If the load fluctuates greatly in the middle of stroke, calculate the equivalent load (P<sub>M</sub>) by the following equation. Also, with LPES30 and below, the expected traveling distance becomes 10000km or longer.

$P_M = \frac{P_{MIN} + 2 \times P_{MAX}}{3}$
P <sub>M</sub> : equivalent load N P <sub>MIN</sub> : minimum load N P <sub>MAX</sub> : maximum load N

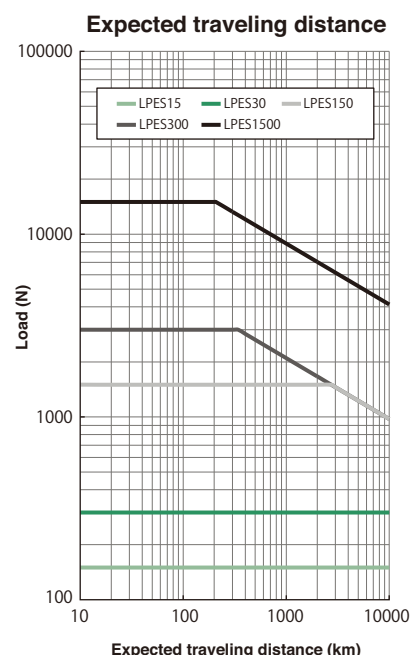

# Calculation site for simple selection

Model No. corresponding required specifications is selected on the website.

HOME > Power Transmission Products > Linear Actuator > Actuator > Power Cylinder > Eco Series (Servo Type)  
<http://tsubakimoto.com/power-transmission/linear-actuator/electro-mechanical/power-cylinder/servo/>

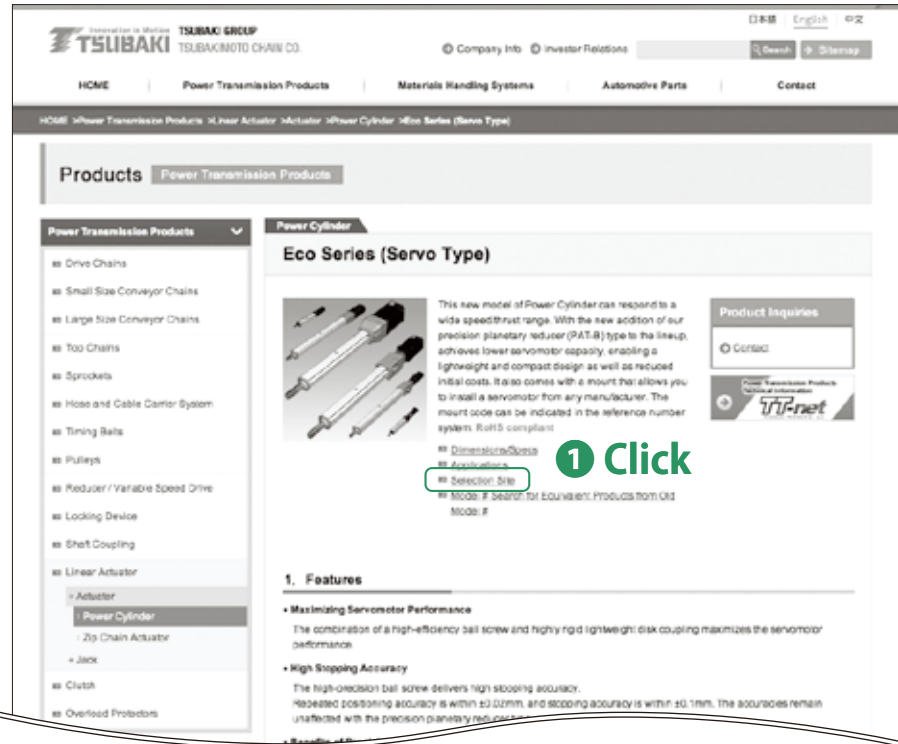

HOME > Sizing > Power Cylinder Eco Series Servo Type  
[https://tt-net.tsubakimoto.co.jp/tecs/calc/sad/lpe/calc\\_lpes.asp?lang=en](https://tt-net.tsubakimoto.co.jp/tecs/calc/sad/lpe/calc_lpes.asp?lang=en)

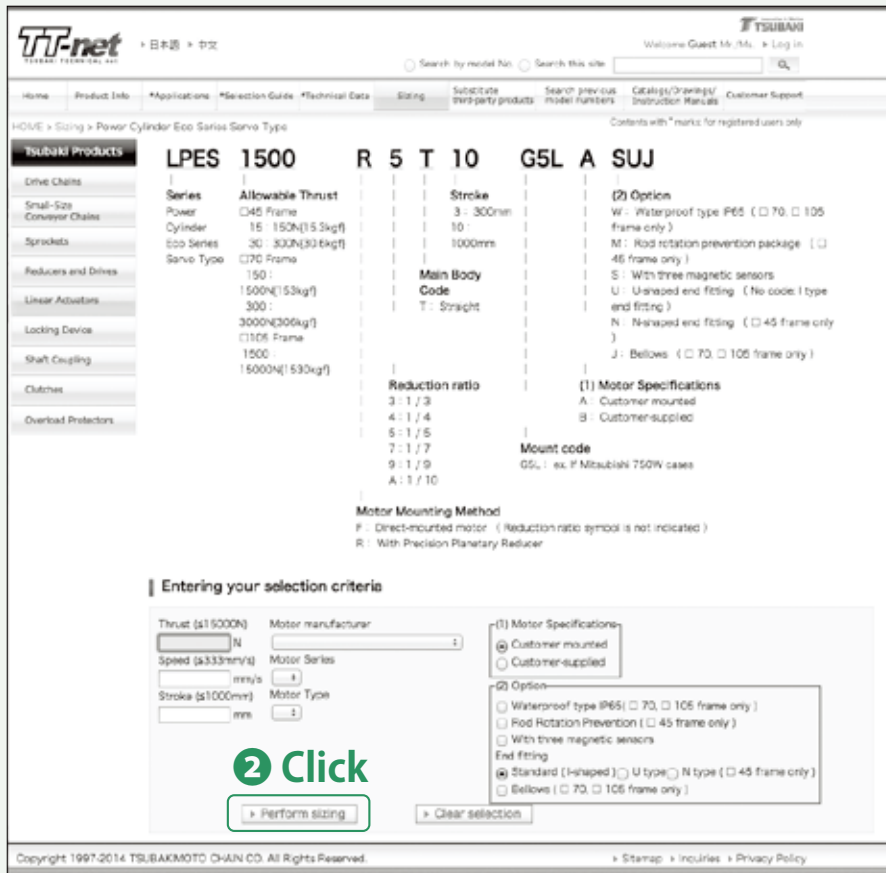

Input necessary conditions and execute selection.

# Servomotor matching table

## Motors manufactured by Mitsubishi Electric

●J4 series HG-KR/HG-MR ●J3 series HF-KP/HF-MP ●J2-Super series HC-KFS/HC-MFS

Motor type	Motor capacity kW	Power cylinder model No.	Mount code	Reducer frame No.	Motor direct coupling		Reduction gear ratio											
					Thrust generated N	Rated speed mm/s	3		4		5		7		9		10	
							Thrust generated N	Rated speed mm/s	Thrust generated N	Rated speed mm/s	Thrust generated N	Rated speed mm/s	Thrust generated N	Rated speed mm/s	Thrust generated N	Rated speed mm/s	Thrust generated N	Rated speed mm/s
HG-KR053(B) HG-MR053(B) HF-KP053(B) HF-MP053(B) HC-KFS053(B) HC-MFS053(B)	0.05	LPE15F	B3D	-	40	300												
LPE30R		B3D	120			130	100	220	75	290	60	300	43	300	33	300	30	
HG-KR13(B) HG-MR13(B) HF-KP13(B) HF-MP13(B) HC-KFS13(B) HC-MFS13(B)	0.1	LPE15F	B3D	-	150	300												
LPE30F		B3D	-	190	300													
LPE30R		B3D	120			300	100	300	75	300	60							
LPE150R		B3D	160									310	43	550	33	810	30	
HG-KR23(B) HG-MR23(B) HF-KP23(B) HF-MP23(B) HC-KFS23(B) HC-MFS23(B)	0.2	LPE30F	E4H	-	300	300												
LPE150R		E4H	160			600	100	1100	75	1500	60	1500	43	1500	33	1500	30	
LPE300R		E4H	160							1300	60	2100	43	3000	33	3000	30	
HG-KR43(B) HG-MR43(B) HF-KP43(B) HF-MP43(B) HC-KFS43(B) HC-MFS43(B)	0.4	LPE150R	E4H	160			1500	100	1500	75								
LPE300R		E4H	160			2200	100	3000	75	3000	60	3000	43					
HG-KR73(B) HG-MR73(B) HF-KP73(B) HF-MP73(B) HC-KFS73(B) HC-MFS73(B)	0.75	LPE150F	G5L	-	1200	300												
LPE300R		G5L	220			3000	100											
LPE1500R		G5L	220			1600	167	2700	125	3900	100	6300	71	8600	56	9800	50	

●J4 series HG-SR ●J3 series HF-SP ●J2-Super series HC-SFS

HG-SR51(B)	0.5	LPE300F	K3Y	-	3000	100											
LPE1500R		K3Y	220			5800	56	8300	42	11000	33	15000	24	15000	19	15000	17
HF-SP51(B)	0.5	LPE300F	K3Y	-	3000	100											
LPE1500R		K3Y	220			5700	56	8200	42	10900	33	15000	24	15000	19	15000	17
HG-SR81(B) HF-SP81(B) HC-SFS81(B)	0.85	LPE1500F	K3Y	-	2700	167											
LPE1500R		K3Y	220			11400	56	15000	42	15000	33						
HG-SR121(B) HF-SP121(B) HC-SFS121(B)	1.2	LPE1500F	L3R	-	4600	167											
LPE1500R		L1R	400			15000	56										
HG-SR201(B) HF-SP201(B) HC-SFS201(B)	2	LPE1500F	L3R	-	8900	167											
LPE1500R		L3R	-	14300	167												
HG-SR301(B) HF-SP301(B) HC-SFS301(B)	3	LPE1500F	L3R	-	14300	167											
LPE1500R		L3R	-	14300	167												
HG-SR52(B) HF-SP52(B) HC-SFS52(B)	0.5	LPE300R	K3Y	220			3000	67	3000	50							
LPE1500R		K3Y	220			1600	111	2900	83	4000	67	6300	48	8600	37	10000	33
HG-SR102(B)	1	LPE300F	K3Y	-	3000	200											
LPE1500R		K3Y	220			5700	111	8300	83	10800	67	15000	48	15000	37	15000	33
HF-SP102(B) HC-SFS102(B)	1	LPE300F	K3Y	-	3000	200											
LPE1500R		K3Y	220			5600	111	8200	83	10700	67	15000	48	15000	37	15000	33
HG-SR152(B)	1.5	LPE1500F	K3Y	-	2000	333											
LPE1500R		K3Y	220			9700	111	13700	83	15000	67						
HF-SP152(B) HC-SFS152(B)	1.5	LPE1500F	K3Y	-	2000	333											
LPE1500R		K3Y	220			9700	111	13600	83	15000	67						
HG-SR202(B)	2	LPE1500F	L3R	-	3300	333											
LPE1500R		L1R	400			11700	111	15000	83								
HF-SP202(B) HC-SFS202(B)	2	LPE1500F	L3R	-	3300	333											
LPE1500R		L1R	400			11800	111	15000	83								
HG-SR352(B) HF-SP352(B) HC-SFS352(B)	3.5	LPE1500F	L3R	-	7400	333											
LPE1500R		L1R	400			15000	111										
HG-SR502(B) HF-SP502(B) HC-SFS502(B)	5	LPE1500F	L3R	-	11500	333											
LPE1500R		L3R	-	11500	333												
HG-SR702(B) HF-SP702(B) HC-SFS702(B)	7	LPE1500F	L3R	-	15000	333											
LPE1500R		L3R	-	15000	333												

●J3 series HA-LP

HA-LP701M(B)	7	LPE1500F	N1S	-	15000	250											
HA-LP701M4(B)	7	LPE1500F	N1S	-	15000	250											
HA-LP502	5	LPE1500F	N1S	-	11500	333											
HA-LP702	7	LPE1500F	N1S	-	15000	333											
HA-LP1K24(B)	11	LPE1500F	N1S	-	15000	333											

\* Gray-shaded areas show numerical values with precision planetary reducer.  
 \* Shaded thrusts generated require thrust limits. Make sure to use at the specified thrusts or less.  
 \* Shaded rated speeds require speed limits. Make sure to use at the specified speeds or less.



# Servomotor matching table

## Motors manufactured by Yaskawa Electric

● Σ V series SGMJV/SGMAV ● Σ II series SGMAH

Motor type	Motor capacity kW	Power cylinder model No.	Mount code	Reducer frame No.	Motor direct coupling		Reduction gear ratio														
					Thrust generated N	Rated speed mm/s	3		4		5		7		9		10				
							Thrust generated N	Rated speed mm/s	Thrust generated N	Rated speed mm/s	Thrust generated N	Rated speed mm/s	Thrust generated N	Rated speed mm/s	Thrust generated N	Rated speed mm/s	Thrust generated N	Rated speed mm/s			
SGMAH-A3	0.03	LPES30R	B3B	120																	
SGMJV-A5 SGMAV-A5 SGMAH-A5	0.05	LPES15F LPES30R LPES150R	B3D B3D B3D	- 120 160	40 300	300	120	100	210	75	290	60	300	43	300	33	300	30			
SGMJV-01 SGMAV-01 SGMAH-01	0.1	LPES15F LPES30F LPES30R LPES150R	B3D B3D B3D B3D	- - 120 160	150 300	300															
SGMJV-C2 SGMAV-C2	0.15	LPES30F LPES150R LPES300R	B3D B3D B3D	- 160 160	300	300			550	75	810	60	1300	43	1500	33	1500	30			
SGMJV-02 SGMAV-02 SGMAH-02	0.2	LPES150R LPES300R	E4H E4H	160 160			590	100	1100	75	1500	60	1500	43	2900	33	3000	30			
SGMAH-03	0.3	LPES150R LPES300R	E4H E4H	160 160			1400	100	1500	75	2100	75	2800	60	3000	43					
SGMJV-04 SGMAV-04 SGMAH-04	0.4	LPES150R LPES300R	E4H E4H	160 160			1500	100	1500	75	3000	60	3000	43							
SGMAV-06	0.55	LPES150F LPES300R	E4H E4H	- 160	630 300	300	3000	100													
SGMJV-06	0.6	LPES150F LPES300R LPES150F	E4H E4H G5K	- 160 -	780 300	300	3000	100													
SGMAH-07	0.65	LPES300R LPES1500R	G5K G5K	160 220			3000	100		2000	125	3000	100	5000	71	7000	56	7900	50		
SGMJV-08 SGMAV-08 SGMAH-08	0.75	LPES150F LPES1500R	G5L G5L	- 220	1200 300	300															
SGMAV-10	1	LPES300F LPES1500R	G5L G5L	- 220	1800 300	300															
							2900	167	4500	125	6100	100	9400	71	12600	56	14200	50			

● Σ V series SGMGV

SGMGV-03	0.3	LPES300R LPES1500R	H1H H4H	160 220			3000	50	3000	38											
SGMGV-05	0.45	LPES300F LPES1500R	H2K H4K	- 220	1700	150			1900	63	2800	50	4600	36	6600	28	7500	25			
SGMGV-09	0.85	LPES300F LPES1500R	K3L K3L	- 220	3000	150															
SGMGV-13	1.3	LPES1500F LPES1500R	K3M K3M	- 220	2700	250															
SGMGV-20	1.8	LPES1500F LPES1500R	K3Y K3Y	- 220	4400	250															
SGMGV-30	2.9	LPES1500F	L3R	-	8500	250															
SGMGV-44	4.4	LPES1500F	L3R	-	14000	250															
SGMGV-55	5.5	LPES1500F	L2S	-	15000	250															

● Σ V series SGMZS (explosion-proof type)

SGMZS-02	0.2	LPES30F LPES150R LPES300R	H1H H1H H1H	- 160 160	300	300															
SGMZS-05	0.5	LPES300R LPES1500R	J7Y J7Y	220 220			2500	100	3000	75	3000	60	3000	43							
SGMZS-10	1	LPES300F LPES300R LPES1500R	J7Y J7Y J7Y	- 220 220	1800	300															
SGMZS-18	1.8	LPES300F LPES1500R	J8Y J7Y	- 220	3000	300															
SGMZS-30A2A	2.97	LPES1500F LPES1500R	M3P M3P	- 320	3300	333															
SGMZS-30A2B	2.96	LPES1500F LPES1500R	M4P M4P	- 320	5900	333															
							15000	111	15000	83	15000	67									

\* Gray-shaded areas show numerical values with precision planetary reducer.

\* Shaded thrusts generated require thrust limits. Make sure to use at the specified thrusts or less.

\* Shaded rated speeds require speed limits. Make sure to use at the specified speeds or less.

\* Mount codes may change with oil seal. Please contact us or check with the selection tool.

## Motors manufactured by Panasonic

### ●MINAS A5 series MHMD/MSME/MSMD

Motor type	Motor capacity kW	Power cylinder model No.	Mount code	Reducer frame No.	Motor direct coupling		Reduction gear ratio													
					Thrust generated N	Rated speed mm/s	3		4		5		7		9		10			
							Thrust generated N	Rated speed mm/s	Thrust generated N	Rated speed mm/s	Thrust generated N	Rated speed mm/s	Thrust generated N	Rated speed mm/s	Thrust generated N	Rated speed mm/s	Thrust generated N	Rated speed mm/s		
MSME5A MSMD5A	0.05	LPE515F	B2D	-	40	300														
		LPE530R	B2D	120			130	100	220	75	290	60	300	43	300	33	300	30		
MSME01 MSMD01	0.1	LPE515F	B2D	-	150	300														
		LPE530F	B2D	-	190	300														
MHMD02 MSME02 MSMD02	0.2	LPE530F	B2D	120			300	100	300	75	300	60								
		LPE530F	E3G	-	300	300														
MHMD04 MSME04 MSMD04	0.4	LPE5150R	E3G	160			600	100	1100	75	1500	60	1500	43	1500	33	1500	30		
		LPE5150R	E3H	160			1500	100	1500	75										
MHMD08 MSME08 MSMD08	0.75	LPE5300R	E3H	160			2200	100	3000	75	3000	60	3000	43						
		LPE5150F	G4L	-	1200	300														
MSME10	1	LPE5300R	G4L	220			3000	100												
		LPE5150R	G4L	220			1600	167	2700	125	3900	100	6300	71	8600	56	9800	50		
MSME15	1.5	LPE5300F	J5L	-	1800	300														
		LPE51500R	J5L	220			2900	167	4500	125	6100	100	9400	71	12600	56	14200	50		
MSME20	2	LPE5300F	J5L	-	3000	300														
		LPE51500R	J5L	220			5600	167	8100	125	10600	100	15000	71	15000	56	15000	50		
MSME30	3	LPE51500F	K3M	-	3300	333														
		LPE51500R	K3M	220			13700	167	15000	125										
MSME40	4	LPE51500F	K4Y	-	5100	333														
		LPE51500R	K4Y	220			15000	167												
MSME50	5	LPE51500F	K4Y	-	6900	333														

### ●MINAS A5 series MDME ●MINAS A4 series MDMA

MDMA08	0.75	LPE5300F	K3L	-	2100	200														
MDME10	1	LPE51500R	K3L	220			3600	111	5500	83	7300	67	11000	48	14600	37	15000	33		
		LPE5300F	K3M	-	3000	200														
MDMA10	1	LPE51500R	K3M	220			5600	111	8200	83	10700	67	15000	48	15000	37	15000	33		
		LPE5300F	K3M	-	3000	200														
MDME15 MDMA15	1.5	LPE51500F	K3M	-	2000	333														
		LPE51500R	K3M	220			9700	111	13600	83	15000	67								
MDME20 MDMA20	2	LPE51500F	K3M	-	3300	333														
		LPE51500R	K3M	220			13700	111	15000	83										
MDMA25	2.5	LPE51500F	K4Y	-	4600	333														
		LPE51500R	K4Y	220			15000	111	15000	83	15000	67								
MDME30 MDMA30	3	LPE51500F	K4Y	-	6000	333														
		LPE51500R	K4Y	220			15000	111												
MDMA35	3.5	LPE51500F	M3P	-	7300	333														
MDME40	4	LPE51500F	L1R	-	8700	333														
MDMA40	4	LPE51500F	M3P	-	8600	333														
MDMA45	4.5	LPE51500F	L1R	-	10000	333														
MDME50	5	LPE51500F	L1R	-	11500	333														
MDMA50	5	LPE51500F	L1R	-	11400	333														
MDME75 MDMA75	7.5	LPE51500F	L2S	-	15000	250														

### ●MINAS A5 series MFME ●MINAS A4 series MFMA

MFMA04	0.4	LPE5300R	K3L	220			3000	67	3000	50	3000	40								
		LPE51500R	K3L	220						1700	83	2600	67	4300	48	6100	37	7100	33	
MFMA08	0.75	LPE5300F	L1M	-	2100	200														
		LPE51500R	L1M	220			3600	111	5500	83	7300	67	11000	48	14600	37	15000	33		
MFME15 MFMA15	1.5	LPE51500F	L1R	-	2000	333														
		LPE51500R	L1R	400			7700	111	11100	83	14300	67	15000	48	15000	37	15000	33		
MFME25	2.5	LPE51500F	P2R	-	4700	333														
		LPE51500R	P2R	400			15000	111	15000	83	15000	67								
MFMA25	2.5	LPE51500F	P2R	-	4600	333														
		LPE51500R	P2R	400			15000	111	15000	83	15000	67								
MFMA35	3.5	LPE51500F	P2R	-	7300	333														
		LPE51500R	P2R	400			15000	111	15000	83										
MFME45 MFMA45	4.5	LPE51500F	P3R	-	10100	333														
		LPE51500R	P3R	-	10100	333														

\* Gray-shaded areas show numerical values with precision planetary reducer.  
 \* Shaded thrusts generated require thrust limits. Make sure to use at the specified thrusts or less.  
 \* Shaded rated speeds require speed limits. Make sure to use at the specified speeds or less.

# Servomotor matching table

## Motors manufactured by Fuji Electric

●ALPHA 5 series GYS ●FALDIC-α series GYS

Motor type	Motor capacity kW	Power cylinder model No.	Mount code	Reducer frame No.	Motor direct coupling		Reduction gear ratio														
					Thrust generated N	Rated speed mm/s	3		4		5		7		9		10				
							Thrust generated N	Rated speed mm/s	Thrust generated N	Rated speed mm/s	Thrust generated N	Rated speed mm/s	Thrust generated N	Rated speed mm/s	Thrust generated N	Rated speed mm/s	Thrust generated N	Rated speed mm/s			
GYS500D5 GYS500DC	0.05	LPES15F	B3B	-	40	300															
							LPES30R	B3B	120		120	100	210	75	290	60	300	43	300	33	300
GYS101D5 GYS101DC	0.1	LPES15F	B3D	-	150	300															
							LPES30F	B3D	-	190	300										
							LPES30R	B3D	120		300	100	300	75	300	60					
GYS201D5 GYS201DC	0.2	LPES150R	B3D	160	-	300															
							LPES30F	E4H	-	300	300										
							LPES150R	E4H	160		590	100	1100	75	1500	60	1500	43	1500	33	1500
GYS401D5-□□6 GYS371DC	0.375	LPES150R	E4H	160	-	-															
							LPES300R	E4H	160		1800	100	2900	75	3000	60	3000	43	3000	33	
GYS401D5-□□2 GYS401DC	0.4	LPES150R	E4H	160	-	-															
							LPES300R	E4H	160		2100	100	3000	75	3000	60	3000	43			
GYS751D5 GYS751DC	0.75	LPES150F	G5K	-	1200	300															
							LPES300R	G5K	160		3000	100									
							LPES1500R	G5K	220		1600	167	2700	125	3900	100	6300	71	8600	56	9700
GYS102D	1	LPES300F	J4Y	-	1800	300															
							LPES1500R	J4Y	220		2900	167	4500	125	6100	100	9400	71	12600	56	14200
GYS152D	1.5	LPES300F	J4Y	-	3000	300															
							LPES1500R	J4Y	220		5600	167	8100	125	10600	100	15000	71	15000	56	15000
GYS202D	2	LPES1500F	J4Y	-	1500	333															
							LPES1500R	J4Y	220		8300	167	11700	125	15000	100					
GYS302D	3	LPES1500F	K4P	-	3300	333															
							LPES1500R	K4P	320		12300	167	15000	125							
GYS402D	4	LPES1500F	K4P	-	5100	333															
							LPES1500R	K4P	320		15000	167									
GYS502D	5	LPES1500F	K4P	-	6900	333															

●ALPHA 5 series GYC ●FALDIC-α series GYC

GYC101D5 GYC101DC	0.1	LPES30F	E5D	-	190	300																
							LPES30R	E4D	120		300	100	300	75	300	60						
							LPES150R	E4D	160							300	43	530	33	800	30	
GYC201D5 GYC201DC	0.2	LPES30F	G2H	-	300	300																
							LPES150R	G5H	160		590	100	1100	75	1500	60	1500	43	1500	33	1500	30
							LPES300R	G5H	160						1300	60	2100	43	2900	33	3000	30
GYC401D5 GYC401DC	0.4	LPES150R	G5H	160	-	-																
							LPES300R	G5H	160		2100	100	3000	75	3000	60	3000	43				
							LPES1500R	G5H	220							1900	71	2900	56	3400	50	
GYC751D5 GYC751DC	0.75	LPES300R	J2K	160	-	-																
							LPES1500R	J2K	220		1600	167	2700	125	3900	100	6300	71	8600	56	9700	50
GYC102D5 GYC102DC	1	LPES300F	K3Y	-	1800	300																
							LPES1500R	K3Y	220		2900	167	4500	125	6100	100	9400	71	12600	56	14200	50
GYC152D5 GYC152DC	1.5	LPES300F	K3Y	-	3000	300																
							LPES1500R	K3Y	220		5600	167	8100	125	10600	100	15000	71	15000	56	15000	50
GYC202D5 GYC202DC	2	LPES1500F	K3Y	-	1500	333																
							LPES1500R	K3Y	220		8300	167	11700	125	15000	100						

●ALPHA 5 series GYG ●FALDIC-W series GYG

GYG501C	0.5	LPES300R	K3L	220	-	-																
							LPES1500R	K3L	220		1600	111	2800	83	4000	67	6300	48	8600	37	9900	33
GYG501B	0.5	LPES300F	K3L	220	-	2000																
							LPES300R	K3L	220		3000	83	4600	63	6200	50	9400	36	12800	28	14400	25
							LPES1500R	K3L	220													
GYG751C	0.75	LPES300F	K3L	220	-	2200																
							LPES1500R	K3L	220		3600	111	5500	83	7400	67	11000	48	14600	37	15000	33
GYG851B	0.85	LPES300F	K3L	220	-	3000																
							LPES1500R	K3L	220		6800	83	9700	63	12500	50	15000	36	15000	28	15000	25
GYG102C	1	LPES300F	K3M	-	3000	200																
							LPES1500R	K3M	220		5600	111	8200	83	10700	67	15000	48	15000	37		
GYG132B	1.3	LPES1500F	K3M	-	2600	250																
							LPES1500R	K3M	220		11700	83	15000	63	15000	50						
GYG152C	1.5	LPES1500F	K3M	-	2000	333																
							LPES1500R	K3M	220		9700	111	13600	83	15000	67						
GYG202C	2	LPES1500F	K3M	-	3300	333																
							LPES1500R	K3M	220		13700	111	15000	83								
GYG182BC	1.8	LPES1500F	L3R	-	4400	250																
							LPES1500R	L3R	400		15000	83	15000	63	15000	50						
GYG292BC	2.9	LPES1500F	L3R	-	8400	250																

\* Gray-shaded areas show numerical values with precision planetary reducer.  
 \* Shaded thrusts generated require thrust limits. Make sure to use at the specified thrusts or less.  
 \* Shaded rated speeds require speed limits. Make sure to use at the specified speeds or less.

## Motors manufactured by Omron

### ●R88M-K series

Motor type	Motor capacity kW	Power cylinder model No.	Mount code	Reducer frame No.	Motor direct coupling		Reduction gear ratio													
					Thrust generated N	Rated speed mm/s	3		4		5		7		9		10			
							Thrust generated N	Rated speed mm/s	Thrust generated N	Rated speed mm/s	Thrust generated N	Rated speed mm/s	Thrust generated N	Rated speed mm/s	Thrust generated N	Rated speed mm/s	Thrust generated N	Rated speed mm/s		
R88M-K05030H (T)	0.05	LPE515F	B3D	-	40	300														
		LPE530R	B3D	120			130	100	220	75	290	60	300	43	300	33	300	30		
R88M-K10030L (S) R88M-K10030H (T)	0.1	LPE515F	B3D	-	150	300														
		LPE530F	B3D	-	190	300														
		LPE530R	B3D	120			300	100	300	75	300	60								
R88M-K20030L (S) R88M-K20030H (T)	0.2	LPE5150R	B3D	160									310	43	550	33	810	30		
		LPE530F	E3G	-	300	300														
		LPE530R	E3G	160			600	100	1100	75	1500	60	1500	43	1500	33	1500	30		
R88M-K40030L (S) R88M-K40030H (T)	0.4	LPE5150R	E3H	160			1500	100	1500	75										
		LPE530R	E3H	160			2200	100	3000	75	3000	60	3000	43						
R88M-K40020F (C)	0.4	LPE5300R	J4L	220			3000	67	3000	50	3000	40								
		LPE51500R	J4L	220					1800	83	2600	67	4400	48	6100	37	7200	33		
R88M-K60020F (C)	0.6	LPE5300F	J5L	-	1500	200														
		LPE51500R	J4L	220			2400	111	3900	83	5300	67	8100	48	11000	37	12600	33		
R88M-K75030H (T)	0.75	LPE5150F	G4L	-	1200	300														
		LPE5300R	G4L	220			3000	100												
R88M-K75030F (C)	0.75	LPE51500R	G4L	220			1600	167	2700	125	3900	100	6300	71	8600	56	9800	50		
		LPE5300R	J4L	220			3000	100	3000	75										
R88M-K90010H (T) R88M-K90010F (C)	0.9	LPE51500F	K7M	-	3000	167														
		LPE51500R	K3M	220			12200	56	15000	42	15000	33	15000	24						
R88M-K1K030H (T) R88M-K1K030F (C)	1	LPE5300F	J5L	-	1800	300														
		LPE51500R	J4L	220			2900	167	4500	125	6100	100	9400	71	12600	56	14200	50		
R88M-K1K020H (T) R88M-K1K020F (C)	1	LPE5300F	K3M	-	3000	200														
		LPE51500R	K3M	220			5600	111	8200	83	10700	67	15000	48	15000	37	15000	33		
R88M-K1K530H (T) R88M-K1K530F (C)	1.5	LPE5300F	J5L	-	3000	300														
		LPE51500R	J4L	220			5600	167	8100	125	10600	100	15000	71	15000	56	15000	50		
R88M-K1K520H (T) R88M-K1K520F (C)	1.5	LPE51500F	K3M	-	2000	333														
		LPE51500R	K3M	220			9700	111	13600	83	15000	67								
R88M-K2K030H (T) R88M-K2K030F (C)	2	LPE51500R	J4L	220			8300	167	11700	125	15000	100								
		LPE51500F	K3M	-	3300	333														
R88M-K2K020H (T) R88M-K2K020F (C)	2	LPE51500R	K3M	220			13700	111	15000	83										
		LPE51500F	L3R	-	8900	167														
R88M-K2K010H (T) R88M-K2K010F (C)	2	LPE51500R	L1R	400			15000	56												
		LPE51500F	K3M	-	3300	333														
R88M-K3K030H (T) R88M-K3K030F (C)	3	LPE51500R	K3M	220			13700	167	15000	125										
		LPE51500F	K4Y	-	6000	333														
R88M-K3K020H (T) R88M-K3K020F (C)	3	LPE51500R	K4Y	220			15000	111												
		LPE51500F	L3R	-	14400	167														
R88M-K4K030H (T) R88M-K4K030F (C)	4	LPE51500F	K4Y	-	5100	333														
		LPE51500R	K4Y	220			15000	167												
R88M-K4K020H (T) R88M-K4K020F (C)	4	LPE51500F	L1R	-	8700	333														
		LPE51500R	L1R	-	11500	333														

### ●R7M-A/Z series

R7M-A03030	0.03	LPE530R	B3B	120											30	33	60	30		
R7M-A05030	0.05	LPE515F	B3B	-	40	300														
		LPE530R	B3B	120			120	100	210	75	290	60	300	43	300	33	300	30		
R7M-A10030 R7M-Z10030-S1	0.1	LPE515F	B3D	-	150	300														
		LPE530F	B3D	-	190	300														
		LPE530R	B3D	120			300	100	300	75	300	60								
R7M-A20030 R7M-Z20030-S1	0.2	LPE5150R	B3D	160									300	43	530	33	800	30		
		LPE530F	E4H	-	300	300														
		LPE5150R	E4H	160			590	100	1100	75	1500	60	1500	43	1500	33	1500	30		
R7M-A40030 R7M-Z40030-S1	0.4	LPE5300R	E4H	160								1300	60	2100	43	2900	33	3000	30	
		LPE5150R	E4H	160			1500	100	1500	75										
R7M-A75030 R7M-Z75030-S1	0.75	LPE5300R	E4H	160			2100	100	3000	75	3000	60	3000	43						
		LPE5150F	G5K	-	1200	300														
		LPE51500R	G5K	220			3000	100												
							1600	167	2700	125	3900	100	6300	71	8600	56	9700	50		

- \* Gray-shaded areas show numerical values with precision planetary reducer.
- \* Shaded thrusts generated require thrust limits. Make sure to use at the specified thrusts or less.
- \* Shaded rated speeds require speed limits. Make sure to use at the specified speeds or less.



# Servomotor matching table

## Motors manufactured by Sanyo Denki

### ●R2 series

Motor type	Motor capacity kW	Power cylinder model No.	Mount code	Reducer frame No.	Reduction gear ratio													
					Motor direct coupling		3		4		5		7		9		10	
					Thrust generated N	Rated speed mm/s	Thrust generated N	Rated speed mm/s	Thrust generated N	Rated speed mm/s	Thrust generated N	Rated speed mm/s	Thrust generated N	Rated speed mm/s	Thrust generated N	Rated speed mm/s	Thrust generated N	Rated speed mm/s
R2AA04003F R2EA04003F	0.03	LPES30R	B4B	120									30	43	50	33	90	30
R2AA04005F R2EA04005F	0.05	LPES15F	B3D	-	40	300												
		LPES30R	B4D	120			120	100	210	75	290	60	300	43	300	33	300	30
R2EA04008F	0.08	LPES15F	B3D	-	130	300												
		LPES30R	B4D	120			300	100	300	75	300	60						
R2AA04010F	0.1	LPES15F	B3D	-	150	300												
		LPES30F	B3D	-	190	300												
		LPES30R	B4D	120			300	100	300	75	300	60						
R2AA06010F	0.1	LPES150R	B3D	160								300	43	530	33	800	30	
		LPES30F	E5D	-	190	300												
		LPES30R	E4D	120			300	100	300	75	300	60						
R2AA06020F R2EA06020F	0.2	LPES150R	E4D	160								300	43	530	33	800	30	
		LPES300R	E4H	160								300	43	530	33	800	30	
		LPES30F	E4H	-	300	300												
R2AA08020F	0.2	LPES150R	G5H	160			590	100	1100	75	1500	60	1500	43	1500	33	1500	30
		LPES300R	G5H	160							1300	60	2100	43	2900	33	3000	30
		LPES30F	G2H	-	300	300												
R2AA06040F	0.4	LPES150R	G5H	160			1500	100	1500	75	1500	60	3000	43				
		LPES300R	E4H	160			2100	100	3000	75	3000	60	3000	43				
		LPES150R	G5H	160			1500	100	1500	75	1500	60	3000	43				
R2AA08040F	0.4	LPES300R	G5H	160			2100	100	3000	75	3000	60	3000	43				
		LPES1500R	G5H	220									1900	71	2900	56	3400	50
		LPES150F	G5K	-	1200	300												
R2AA08075F	0.75	LPES300R	G5K	160			3000	100										
		LPES1500R	G5K	220			1600	167	2700	125	3900	100	6300	71	8600	56	9700	50

### ●Q1 series

Q1AA10100D	1	LPES300F	J4M	-	1800	300												
		LPES300R	J4M	220			3000	100										
		LPES1500R	J4M	220			2900	167	4500	125	6100	100	9500	71	12700	56	14300	50
Q1AA12100D	1	LPES300F	K6M	-	1800	300												
		LPES300R	K6M	220			3000	100										
		LPES1500R	K6M	220			2900	167	4500	125	6100	100	9500	71	12700	56	14300	50
Q1AA10150D	1.5	LPES300F	J4M	-	3000	300												
		LPES1500R	J4M	220			5700	167	8200	125	10700	100	15000	71	15000	56	15000	50
Q1AA10200D	2	LPES1500F	J4M	-	1500	333												
		LPES1500R	J4M	220			8300	167	11700	125	15000	100						
Q1AA12200D	2	LPES300F	K6M	-	3000	300												
		LPES1500F	K6M	-	1500	333												
		LPES1500R	K6M	220			8300	167	11700	125	15000	100	15000	71	15000	56	15000	50
Q1AA10250D	2.5	LPES1500F	J4M	-	2400	333												
		LPES1500R	J4M	220			11000	167	15000	125								
Q1AA12300D	3	LPES1500F	K6P	-	3400	333												
		LPES1500R	K6P	320			12400	167	15000	125								
Q1AA13300D	3	LPES1500F	K3P	-	3300	333												
		LPES1500R	K3P	320			12200	167	15000	125	15000	100	15000	71				
Q1AA13400D	4	LPES1500F	K3P	-	5100	333												
		LPES1500R	K3P	320			15000	167										
Q1AA18450M	4.5	LPES1500F	L1R	-	14100	250												
Q1AA13500D	5	LPES1500F	K3P	-	6800	333												

### ●Q2 series

Q2CA08050H	0.5	LPES300	H1K	160			3000	67										
		LPES1500	H1K	220			1600	111	2900	83	4000	67	6300	48	8600	37	10000	33
Q2AA08100D	1	LPES300	H1K	220			2900	167	4500	125	6100	100	9400	71	12600	56	14200	50
		LPES1500	H1K	220														
Q2AA10100H Q2CA10100H	1	LPES300	J4M	-	3000	200												
		LPES1500	J4M	220			6000	111	8700	83	11400	67	15000	48	15000	37	15000	33
Q2AA13100H	1	LPES300	K3M	-	3000	200												
		LPES1500	K3M	220			6000	111	8700	83	11400	67	15000	48	15000	37	15000	33
Q2AA10150H	1.5	LPES1500	J4M	-	2000	333												
		LPES1500	J4M	220			9700	111	13700	83	15000	67						
Q2AA13150H Q2CA13150H	1.5	LPES1500	K3M	-	2200	333												
		LPES1500	K3M	220			10200	111	14400	83	15000	67						
Q2AA13200H Q2CA13200H	2	LPES1500	K3P	-	3300	333												
		LPES1500	K3P	320			12300	111	15000	83								
Q2AA18200H	2	LPES1500	L1R	-	3300	333												
		LPES1500	L1R	400			11700	111	15000	83	15000	67	15000	48	15000	37		
Q2AA22250H	2.5	LPES1500	P2R	-	4700	333												
		LPES1500	P2R	400			15000	111	15000	83	15000	67						
Q2AA18350H Q2CA18350H	3.5	LPES1500	L1R	-	7400	333												
		LPES1500	L1R	400			15000	111										
Q2AA22350H	3.5	LPES1500	P2R	-	7600	333												
Q2AA18450H Q2CA18450H	4.5	LPES1500	L1R	-	10100	333												
Q2AA22450R	4.5	LPES1500	P2R	-	10100	333												
Q2AA18550R Q2AA18550H	5.5	LPES1500	L3S	-	15000	250												

\* Gray-shaded areas show numerical values with precision planetary reducer.  
 \* Shaded thrusts generated require thrust limits. Make sure to use at the specified thrusts or less.  
 \* Shaded rated speeds require speed limits. Make sure to use at the specified speeds or less.

## Motors manufactured by FANUC

### ● α is series (straight shaft)

Motor type	Motor capacity kW	Power cylinder model No.	Mount code	Reducer frame No.	Reduction gear ratio															
					Motor direct coupling		3		4		5		7		9		10			
					Thrust generated N	Rated speed mm/s	Thrust generated N	Rated speed mm/s	Thrust generated N	Rated speed mm/s	Thrust generated N	Rated speed mm/s	Thrust generated N	Rated speed mm/s	Thrust generated N	Rated speed mm/s	Thrust generated N	Rated speed mm/s		
αiS 2/5000 (HV) (straight shaft)	0.75	LPES300R	H1F	160																
		LPES1500R	H4F	220																
αiS 2/6000 (HV) (straight shaft)	1	LPES300R	H1F	160																
		LPES1500R	H4F	220																
αiS 4/5000 (HV) (straight shaft)	1	LPES300F	Z9Z	-	2600	300														
		LPES1500R	H1H	220																
αiS 8/6000 (HV) (straight shaft)	2.2	LPES1500R	K3L	220																
αiS 8/4000 HV (straight shaft)	2.3	LPES1500R	K3L	220																
αiS 8/4000 (straight shaft)	2.5	LPES1500R	K3L	220																
αiS 12/4000 HV (straight shaft)	2.5	LPES1500F	Z9Z	-	4700	333														
		LPES1500R	K3Y	220																
αiS 12/4000 (straight shaft)	2.7	LPES1500F	Z9Z	-	4700	333														
		LPES1500R	K3Y	220																
αiS 22/4000 (straight shaft)	4.5	LPES1500F	Z9Z	-	10400	333														
αiS 22/4000 HV (straight shaft)		LPES1500F	Z9Z	-	10400	333														
αiS 50/3000 (HV) (straight shaft)	5	LPES1500F	Z9Z	-	15000	333														
αiS 30/4000 (HV) (straight shaft)	5.5	LPES1500F	Z9Z	-	14900	333														
αiS 40/4000 (HV) (straight shaft)	5.5	LPES1500F	Z9Z	-	15000	333														

### ● α iF series (straight shaft)

αiF 1/5000 (straight shaft)	0.5	LPES150R	H1F	160			1500	100	1500	75	1500	60						
		LPES300R	H1F	160			1600	100	2500	75	3000	60	3000	43	3000	33	3000	30
		LPES1500R	H4F	220											1500	56	1900	50
αiF 2/5000 (straight shaft)	0.75	LPES300R	H1F	160			3000	100	3000	75								
		LPES1500R	H4F	220					1800	125	2800	100	4700	71	6600	56	7500	50
αiF 4/4000 (straight shaft)	1.4	LPES300F	Z9Z	-	2700	300												
αiF 4/4000 HV (straight shaft)		LPES1500R	K3L	220			4300	167	6400	125	8400	100	12700	71	15000	56	15000	50
αiF 8/3000 (HV) (straight shaft)	1.6	LPES1500R	K3L	220			11100	167	15000	125	15000	100	15000	71				
αiF 12/3000 (HV) (straight shaft)	3	LPES1500F	Z9Z	-	4700	333												
		LPES1500R	L1R	400			15000	167										
αiF 22/3000 (HV) (straight shaft)	4	LPES1500F	Z9Z	-	10400	333												
αiF 40/3000 (straight shaft)	6	LPES1500F	Z9Z	-	15000	333												
αiF 30/3000 (straight shaft)	7	LPES1500F	Z9Z	-	14900	333												

### ● β is series (straight shaft)

βiS 0.2/5000 (straight shaft)	0.05	LPES15F	Z9Z	-	40	300												
		LPES30R	B4D	120			130	100	220	75	290	60	300	43	300	33	300	30
βiS 0.3/5000 (straight shaft)	0.1	LPES15F	Z9Z	-	150	300												
		LPES30F	Z9Z	-	190	300												
		LPES30R	B4D	120			300	100	300	75	300	60						
βiS 0.4/5000 (straight shaft)	0.13	LPES150R	B3D	160								310	43	550	33	810	30	
		LPES30F	Z9Z	-	270	300												
βiS 0.5/6000 (straight shaft)	0.35	LPES150R	E4E	160						450	60	840	43	1200	33	1500	30	
		LPES300R	E4E	160												1500	30	
		LPES30F	Z9Z	-	300	300												
βiS 1/5000 (straight shaft)	0.4	LPES150R	E4H	160			1500	100	1500	75	1500	60	1500	43	1500	33	1500	30
		LPES300R	E4H	160			1900	100	3000	75	3000	60	3000	43	3000	33		
βiS 1/6000 (straight shaft)	0.5	LPES150R	E4H	160			1500	100	1500	75	3000	60	3000	43				
		LPES300R	E4H	160			2100	100	3000	75	3000	60	3000	43				
βiS 2/4000 (HV) (straight shaft)	0.5	LPES300R	H1F	160			3000	100	3000	75								
		LPES1500R	H4F	220					1800	125	2800	100	4700	71	6600	56	7500	50
βiS 4/4000 (HV) (straight shaft)	0.75	LPES300F	Z9Z	-	2100	300												
		LPES1500R	H1H	220			3500	167	5200	125	7000	100	10700	71	14200	56	15000	50
βiS 8/3000 (HV) (straight shaft)	1.2	LPES300F	Z9Z	-	3000	200												
		LPES1500R	K3L	220			9400	111	13300	83	15000	67	15000	48	15000	37		
βiS 12/2000 (straight shaft)	1.4	LPES1500F	Z9Z	-	3900	333												
		LPES1500R	K3Y	220			15000	111	15000	83	15000	67						
βiS 22/1500 (straight shaft)	1.4	LPES1500F	Z9Z	-	9200	200												
		LPES1500R	L1R	400			15000	67										
βiS 12/3000 (HV) (straight shaft)	1.8	LPES1500F	Z9Z	-	4200	333												
		LPES1500R	K3Y	220			15000	111	15000	83								
βiS 22/2000 (HV) (straight shaft)	2.5	LPES1500F	Z9Z	-	9200	333												

\* Gray-shaded areas show numerical values with precision planetary reducer.  
 \* Shaded thrusts generated require thrust limits. Make sure to use at the specified thrusts or less.  
 \* Shaded rated speeds require speed limits. Make sure to use at the specified speeds or less.

# Servomotor matching table

## Motors manufactured by Keyence

### ● MV series

Motor type	Motor capacity kW	Power cylinder model No.	Mount code	Reducer frame No.	Motor direct coupling		Reduction gear ratio															
					Thrust generated N	Rated speed mm/s	3		4		5		7		9		10					
							Thrust generated N	Rated speed mm/s	Thrust generated N	Rated speed mm/s	Thrust generated N	Rated speed mm/s	Thrust generated N	Rated speed mm/s	Thrust generated N	Rated speed mm/s	Thrust generated N	Rated speed mm/s				
MV-M05 (B05)	0.05	LPES15F	B3D	-	40	300																
		LPES30R	B3D	120			120	100	210	75	290	60	300	43	300	33	300	30				
MV-M10 (B10)	0.1	LPES15F	B3D	-	150	300																
		LPES30F	B3D	-	190	300																
		LPES30R	B3D	120			300	100	300	75	300	60										
		LPES150R	B3D	160									300	43	530	33	800	30				
MV-M20 (B20)	0.2	LPES30F	E4H	-	300	300																
		LPES150R	E4H	160			590	100	1100	75	1500	60	1500	43	1500	33	1500	30				
MV-M40 (B40)	0.4	LPES300R	E4H	160								1300	60	2100	43	2900	33	3000	30			
		LPES150R	E4H	160			1500	100	1500	75												
MV-M75 (B75)	0.75	LPES150F	G4K	-	1200	300																
		LPES300R	G4K	160			3000	100														
		LPES1500R	G4K	220			1600	167	2700	125	3800	100	6200	71	8500	56	9700	50				

### ● SV series

SV-M005 (B005)	0.05	LPES15F	B3D	-	40	300													
		LPES30R	B3D	120			120	100	210	75	290	60	300	43	300	33	300	30	
SV-M010 (B010)	0.1	LPES15F	B3D	-	150	300													
		LPES30F	B3D	-	190	300													
		LPES30R	B3D	120			300	100	300	75	300	60							
		LPES150R	B3D	160									300	43	530	33	800	30	
SV-M020 (B020)	0.2	LPES30F	E4H	-	300	300													
		LPES150R	E4H	160			590	100	1100	75	1500	60	1500	43	1500	33	1500	30	
SV-M040 (B040)	0.4	LPES300R	E4H	160								1300	60	2100	43	2900	33	3000	30
		LPES150R	E4H	160			1500	100	1500	75									
SV-M075 (B075)	0.75	LPES150F	G5L	-	1200	300													
		LPES300R	G5L	220			3000	100											
		LPES1500R	G5L	220			1600	167	2700	125	3900	100	6300	71	8600	56	9700	50	
SV-M100A (B100A)	0.85	LPES300F	K3L	-	3000	150													
		LPES1500R	K3L	220			6800	83	9600	63	12500	50	15000	36	15000	28	15000	25	
SV-M150A (B150A)	1.3	LPES1500F	K3M	-	2700	250													
		LPES1500R	K3M	220			11800	83	15000	63	15000	50							
SV-M200A (B200A)	1.8	LPES1500F	K3Y	-	4400	250													
		LPES1500R	K3Y	220			15000	83											
SV-M300A (B300A)	2.9	LPES1500F	L3R	-	8500	250													
SV-M500A (B500A)	4.4	LPES1500F	L3R	-	14000	250													

\* Gray-shaded areas show numerical values with precision planetary reducer.

\* Shaded thrusts generated require thrust limits. Make sure to use at the specified thrusts or less.

\* Shaded rated speeds require speed limits. Make sure to use at the specified speeds or less.

## Motors manufactured by Nikki Denso

### ●NA100 series

Motor type	Motor capacity kW	Power cylinder model No.	Mount code	Reducer frame No.	Motor direct coupling		Reduction gear ratio											
					Thrust generated N	Rated speed mm/s	3		4		5		7		9		10	
							Thrust generated N	Rated speed mm/s	Thrust generated N	Rated speed mm/s	Thrust generated N	Rated speed mm/s	Thrust generated N	Rated speed mm/s	Thrust generated N	Rated speed mm/s	Thrust generated N	Rated speed mm/s
NA100-110F(B)-10	1.2	LPE1500F	K4Z	-	4600	167												
		LPE1500R	Z9P	320			15000	56	15000	42	15000	33						
NA100-180F(B)-10	1.9	LPE1500F	L1Z	-	8400	167												
		LPE1500R	Z9P	320			13900	111	15000	83	15000	67	15000	48				
NA100-270F(B)-10	2.8	LPE1500F	Z9Z	-	13300	167												
NA100-370F(B)-10	3.7	LPE1500F	L1Z	-	8000	333												
		LPE1500R	Z9P	320			15000	111										
NA100-110F-40	3.7	LPE1500F	K4Z	-	2900	333												
		LPE1500R	Z9P	320			11000	167	15000	125	15000	100	15000	71	15000	56		
NA100-270F(B)	5.5	LPE1500F	Z9Z	-	12800	333												
NA100-180F-40	5.5	LPE1500F	L1Z	-	5400	333												
		LPE1500R	Z9P	320			15000	167										
NA100-370F(B) NA100-370AF(B)	7.5	LPE1500F	Z9Z	-	15000	333												
NA100-270F-40	7.5	LPE1500F	Z9Z	-	8100	333												
NA100-370F-40	11	LPE1500F	Z9Z	-	12800	333												

### ●NA80 series

NA80-05	0.05	LPE15F	B3D	-	40	300												
		LPE30R	Z9D	120			120	100	210	75	290	60	300	43	300	33	300	30
NA80-10	0.1	LPE15F	B3D	-	150	300												
		LPE30F	B3D	-	190	300												
		LPE30R	Z9D	120			300	100	300	75	300	60						
NA80-20	0.2	LPE150R	Z9D	160								300	43	530	33	800	30	
		LPE30F	E4H	-	300	300												
		LPE150R	Z9H	160			600	100	1100	75	1500	60	1500	43	1500	33	1500	30
NA80-40	0.4	LPE150R	Z9H	160			1500	100	1500	75	1300	60	2100	43	3000	33	3000	30
		LPE300R	Z9H	160			2100	100	3000	75	3000	60	3000	43				
		LPE150F	G7L	-	780	300												
NA80-60	0.6	LPE300R	Z9L	220			3000	100										
		LPE1500R	Z9L	220					1600	125	2500	100	4400	71	6100	56	7000	50
NA80-75	0.75	LPE150F	G7L	-	1200	300												
		LPE1500R	Z9L	220			1600	167	2700	125	3900	100	6300	71	8600	56	9700	50
NA830-162	1.6	LPE300F	K2M	-	3000	300												
		LPE1500R	Z9M	220			6200	167	8800	125	11500	100	15000	71	15000	56	15000	50
NA830-332	3.3	LPE1500F	K2M	-	3900	333												
		LPE1500R	Z9M	220			15000	167	15000	125	15000	100						
NA820-402	4	LPE1500F	L1Q	-	8700	333												
		LPE1500R	Z9Q	320			15000	111										
NA820-602	6	LPE1500F	L1Q	-	14100	333												
NA820-752	7.5	LPE1500F	L1Q	-	15000	333												

\* Gray-shaded areas show numerical values with precision planetary reducer.  
 \* Shaded thrusts generated require thrust limits. Make sure to use at the specified thrusts or less.  
 \* Shaded rated speeds require speed limits. Make sure to use at the specified speeds or less.

## Servomotor matching table

### Motors manufactured by Tamagawa Seiki

#### ●TBL-i II series

Motor type	Motor capacity kW	Power cylinder model No.	Mount code	Reducer frame No.	Motor direct coupling		Reduction gear ratio											
					Thrust generated N	Rated speed mm/s	3		4		5		7		9		10	
							Thrust generated N	Rated speed mm/s	Thrust generated N	Rated speed mm/s	Thrust generated N	Rated speed mm/s	Thrust generated N	Rated speed mm/s	Thrust generated N	Rated speed mm/s	Thrust generated N	Rated speed mm/s
TS4601	0.03	LPES30R	B4D	120											30	33	60	30
TS4602	0.05	LPES15F	B3D	-	40	300												
		LPES30R	B4D	120			120	100	210	75	290	60	300	43	300	33	300	30
		LPES15F	B3D	-	150	300												
TS4603	0.1	LPES30F	B3D	-	190	300												
		LPES30R	B4D	120			300	100	300	75	300	60						
		LPES150R	B3D	160									300	43	530	33	800	30
TS4606	0.1	LPES30F	E5D	-	190	300												
		LPES30R	E4D	120			300	100	300	75	300	60						
		LPES150R	E4D	160									300	43	530	33	800	30
TS4607	0.2	LPES30F	E4H	-	300	300												
		LPES150R	E4H	160			600	100	1100	75	1500	60	1500	43	1500	33	1500	30
		LPES300R	E4H	160								1300	60	2100	43	3000	33	3000
TS4611	0.2	LPES30F	G2H	-	300	300												
		LPES150R	G5H	160			600	100	1100	75	1500	60	1500	43	1500	33	1500	30
		LPES300R	G5H	160								1300	60	2100	43	3000	33	3000
TS4609	0.4	LPES150R	E4H	160			1500	100	1500	75	3000	60	3000	43				
		LPES300R	E4H	160			2100	100	3000	75	3000	60	3000	43				
TS4612	0.4	LPES150R	G5H	160			1500	100	1500	75	3000	60	3000	43				
		LPES300R	G5H	160			2100	100	3000	75	3000	60	3000	43				
		LPES1500R	G5H	220									1900	71	2900	56	3400	50
TS4613	0.6	LPES150F	G7L	-	780	300												
		LPES300R	G5L	220			3000	100										
		LPES1500R	G5L	220					1600	125	2500	100	4400	71	6100	56	7000	50
TS4614	0.75	LPES150F	G7L	-	1200	300												
		LPES1500R	G5L	220			1600	167	2700	125	3900	100	6300	71	8600	56	9700	50
TS4813	1	LPES300F	J2M	-	1900	300												
		LPES1500R	J4M	220			3100	167	4800	125	6400	100	9900	71	13200	56	14900	50
TS4815	1.5	LPES300F	J2M	-	3000	300												
		LPES1500R	J4M	220			5700	167	8200	125	10700	100	15000	71	15000	56	15000	50
TS4833	1.6	LPES1500R	K3M	220			6200	167	8800	125	11500	100						
TS4817	2	LPES1500F	J2M	-	1800	333												
		LPES1500R	J4M	220			9100	167	12700	125	15000	100						
TS4882	2	LPES1500F	L1Q	-	3300	333												
		LPES1500R	L1Q	320			12000	111	15000	83	15000	67	15000	48				
TS4836	3.3	LPES1500F	K2M	-	3900	333												
		LPES1500R	K3M	220			15000	167	15000	125								
TS4884	4	LPES1500F	L1Q	-	8700	333												
		LPES1500R	L1Q	320			15000	111										
TS4839	5	LPES1500F	K2Z	-	6900	333												
TS4887	6	LPES1500F	L1Q	-	14100	333												
TS4889	7.5	LPES1500F	L1Q	-	15000	333												

#### ●TRE series

TS3253 TS3353 TS1983	0.03	LPES30R	B2C	120									30	43	50	33	90	30
TS3252 TS3352 TS1982	0.06	LPES30R	E2D	120			210	100	300	75	300	60	300	43	300	33	300	30
TS3251 TS3351 TS1981	0.1	LPES30F	E2D	-	190	300												
		LPES30R	E2D	120			300	100										
		LPES150R	E2D	160									300	43	540	33	810	30
TS3250 TS3350 TS1980	0.2	LPES30F	G1Z	-	300	300												
		LPES150R	G1Z	160			590	100	1100	75	1500	60	1500	43	1500	33	1500	30
		LPES300R	G1Z	160									1300	60	2100	43	2900	33

\* Gray-shaded areas show numerical values with precision planetary reducer.

\* Shaded thrusts generated require thrust limits. Make sure to use at the specified thrusts or less.

\* Shaded rated speeds require speed limits. Make sure to use at the specified speeds or less.



# Motors manufactured by Hitachi Industrial Equipment Systems

## ADMA series

Motor type	Motor capacity kW	Power cylinder model No.	Mount code	Reducer frame No.	Motor direct coupling		Reduction gear ratio												
					Thrust generated N	Rated speed mm/s	3		4		5		7		9		10		
							Thrust generated N	Rated speed mm/s	Thrust generated N	Rated speed mm/s	Thrust generated N	Rated speed mm/s	Thrust generated N	Rated speed mm/s	Thrust generated N	Rated speed mm/s	Thrust generated N	Rated speed mm/s	
ADMA-R5L ADMA-R5M	0.05	LPES15F	B3D	-	40	300													
ADMA-01L ADMA-01M		0.1	LPES30R	B3D	120			130	100	220	75	290	60	300	43	300	33	300	30
	LPES15F		B3D	-	150	300													
	LPES30F		B3D	-	190	300													
	LPES30R		B3D	120			300	100	300	75	300	60							
ADMA-02L ADMA-02M	0.2	LPES150R	B3D	160									310	43	550	33	810	30	
		LPES30F	E4H	-	300	300													
ADMA-04L ADMA-04M	0.4	LPES150R	E4H	160			1500	100	1500	75	1300	60	1500	43	1500	33	1500	30	
		LPES300R	E4H	160			2100	100	3000	75	3000	60	3000	43					
		LPES150F	G5L	-	1200	300													
ADMA-08L	0.75	LPES300R	G5L	220			3000	100											
		LPES1500R	G5L	220			1600	167	2700	125	3900	100	6300	71	8600	56	9700	50	
ADMA-10L	1	LPES300F	H2Y	-	1800	300													
		LPES1500R	H1Y	220			2900	167	4500	125	6100	100	9400	71	12600	56	14200	50	
ADMA-15L	1.5	LPES300F	H2Y	-	3000	300													
		LPES1500R	H1Y	220			5600	167	8100	125	10600	100	15000	71	15000	56	15000	50	
ADMA-20L	2	LPES1500F	H2Y	-	1500	333													
		LPES1500R	H1Y	220			8300	167	11700	125	15000	100							
ADMA-30L	3	LPES1500F	K4P	-	3300	333													
		LPES1500R	K4P	320			12300	167	15000	125									
ADMA-50L	5	LPES1500F	K4P	-	6900	333													
		LPES1500R	K4P	320			15000	167											

## ADMB series

ADMB-01L ADMB-01M	0.1	LPES30F	E5D	-	190	300												
		LPES30R	E4D	120			300	100	300	75	300	60						
		LPES150R	E4D	160									310	43	550	33	810	30
ADMB-02L ADMB-02M	0.2	LPES30F	G2H	-	300	300												
		LPES150R	G5H	160			600	100	1100	75	1500	60	1500	43	1500	33	1500	30
		LPES300R	G5H	160							1300	60	2100	43	3000	33	3000	30
ADMB-04L ADMB-04M	0.4	LPES150R	G5H	160			1500	100	1500	75								
		LPES300R	G5H	160			2100	100	3000	75	3000	60	3000	43				
		LPES1500R	G5H	220									1900	71	2900	56	3400	50
ADMB-08L	0.75	LPES300R	K3L	220			3000	100										
		LPES1500R	K3L	220			1600	167	2700	125	3900	100	6300	71	8600	56	9700	50
ADMB-10L	1	LPES300F	K2L	-	1800	300												
		LPES1500R	K3L	220			2900	167	4500	125	6100	100	9400	71	12600	56	14200	50

## ADMC series

ADMC-04L	0.4	LPES300F	H2Y	-	1400	150												
		LPES300R	H1Y	220			3000	50	3000	38								
		LPES1500R	H1Y	220			2000	83	3200	63	4400	50	6900	36	9600	28	10800	25
ADMC-08L	0.75	LPES300F	H2Y	-	3000	150												
		LPES1500R	H1Y	220			5700	83	8200	63	10700	50	15000	36	15000	28	15000	25
ADMC-10L	1	LPES1500F	H2Y	-	1500	250												
		LPES1500R	H1Y	220			8400	83	11800	63	15000	50						
ADMC-15L	1.5	LPES1500F	K4P	-	3300	250												
		LPES1500R	K4P	320			12400	83	15000	63								
ADMC-20L	2	LPES1500F	K4P	-	5100	250												
		LPES1500R	K4P	320			15000	83										
ADMC-30L	2.9	LPES1500F	L3R	-	8400	250												
ADMC-45L	4.5	LPES1500F	L3R	-	14100	250												

## ADMG series

ADMG-05HP	0.5	LPES300R	H1K	160			3000	67										
		LPES1500R	H1K	220			1600	111	2900	83	4000	67	6300	48	8600	37	10000	33
ADMG-10HP	1	LPES300F	J4M	-	3000	200												
		LPES1500R	J4M	220			6000	111	8700	83	11400	67	15000	48	15000	37	15000	33
ADMG-15HP	1.5	LPES1500F	K3M	-	2200	333												
		LPES1500R	K3M	220			10300	111	14400	83	15000	67						
ADMG-20HP	2	LPES1500F	K3P	-	3300	333												
		LPES1500R	K3P	320			12300	111	15000	83								
ADMG-35HP	3.5	LPES1500F	L1R	-	7400	333												
		LPES1500R	L1R	400			15000	111										
ADMG-45HP	4.5	LPES1500F	L1R	-	10100	333												

\* Gray-shaded areas show numerical values with precision planetary reducer.  
 \* Shaded thrusts generated require thrust limits. Make sure to use at the specified thrusts or less.  
 \* Shaded rated speeds require speed limits. Make sure to use at the specified speeds or less.

# Motor direct coupling

## Dimensions table (□45 frame)

### LPES15FT

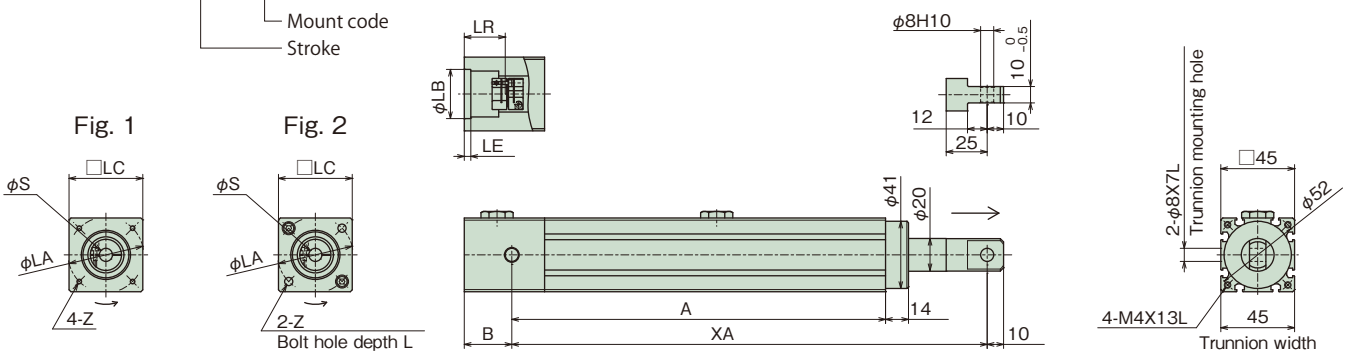

Mount code	LC	LB	LE	S	LR	LA	Z	L	B	Unit: mm
A3D	45	22	4	8	24	48	M3X11L	-	28	1
B2D	45	30	4	8	24	45	M3X11L	-	28	
B3B	45	30	4	6	25	46	M4X13L	49	29	2
B3D	45	30	4	8	25	46	M4X13L	49	29	
C1C	45	34	4	7	24	48	M3X11L	-	28	1
Z9Z										

Stroke	A	Unit: mm	
		MIN	MAX
100	228	290	390
200	328	410	610
300	428	510	810

Stroke	Unit: kg	
	Mass	
100	1.5	
200	1.9	
300	2.2	

\* For dimensions in blanks, contact us.

\* The above mass does not include the mass of the servomotor.

### LPES30FT

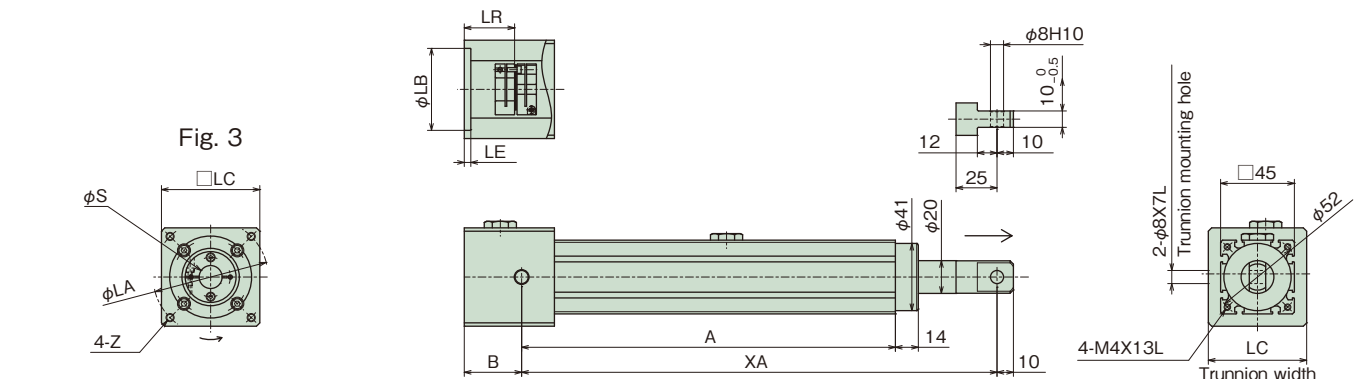
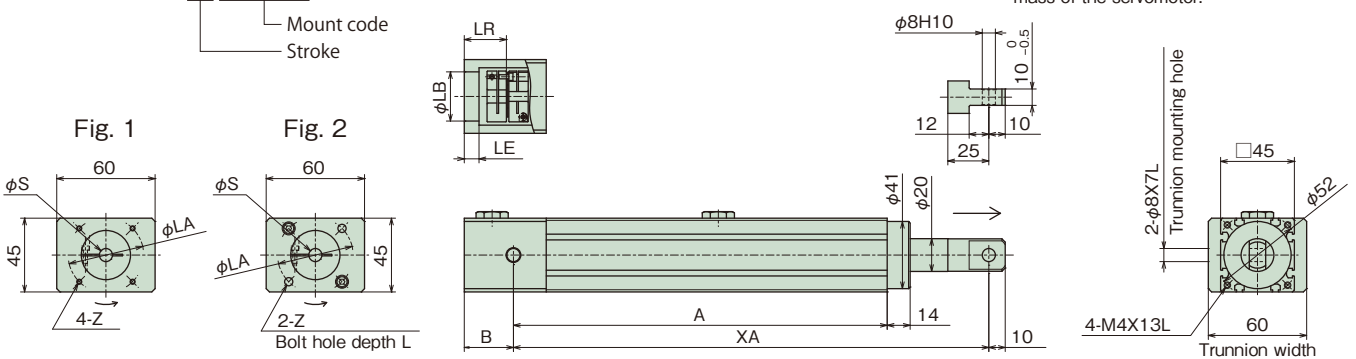

Mount code	LC	LB	LE	S	LR	LA	Z	L	B	Unit: mm
A3D	-	22	8	8	24	48	M3X11L	-	29	1
B2D	-	30	9	8	25	45	M3X11L	-	30	
B3D	-	30	9	8	25	46	M4X13L	50	30	
E1C	60	50	5	7	24	60	M4X12L	-	29	2
E2D	60	50	5	8	30	60	M4X12L	-	35	
E3D	60	50	5	8	25	70	M4X12L	-	30	
E3G	60	50	5	11	30	70	M4X12L	-	35	
E4H	60	50	5	14	30	70	M5X12L	-	35	
E5D	60	50	5	8	25	70	M5X12L	-	30	
G1G	80	70	5	11	30	90	M5X12L	-	35	3
G1H	80	70	5	14	30	90	M5X12L	-	35	
G1Z	80	70	5	12	30	90	M5X12L	-	35	
G2H	80	70	5	14	30	90	M6X17L	-	35	
H1H	90	80	5	14	30	100	M6X17L	-	35	
Z9Z										

Stroke	A	Unit: mm	
		MIN	MAX
100	228	290	390
200	328	410	610
300	428	510	810

Stroke	Unit: kg	
	Mass	
100	1.6	
200	2.0	
300	2.4	

\* For dimensions in blanks, contact us.

\* The above mass does not include the mass of the servomotor.

## With precision planetary reducer

### Dimensions table (□45 frame)

#### LPES30R□T□□□□

Reduction gear ratio — Mount code  
Stroke

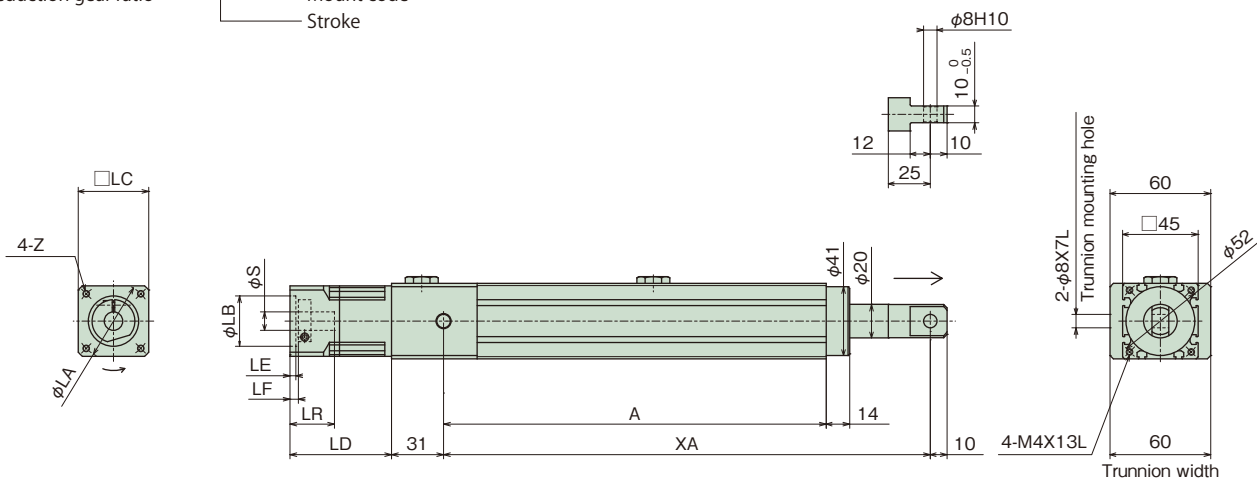

#### With PAT-B120

Mount code	LC	LB	LE	S	LR	LF	LA	Z	LD
A3D	42	22	4	8	30.5	9	48	M3X6L	64.5
B2C									
B2D	42	30	3.5	8	26.5	5	45	M3X6L	60.5
B3B	42	30	3.5	6	26.5	5	45	M4X9L	60.5
B3D	42	30	3.5	8	26.5	5	46	M4X9L	60.5
B4B									
B4D	42	30	8	8	31.5	10	46	M4X9L	65.5
C1C	42	34	3.5	7	26.5	5	48	M3X6L	60.5
E1C									
E2D									
E3D	60	50	3.5	8	31.5	10	70	M4X9L	65.5
E3G	60	50	3.5	11	31.5	10	70	M4X9L	65.5
E4D									
Z9D									

Unit: mm

Stroke	A	XA	
		MIN	MAX
100	228	290	390
200	328	410	610
300	428	510	810

Unit: mm

Stroke	Mass
	100
200	2.6
300	3.0

Unit: kg

\* The above mass does not include the mass of the servomotor.

\* For dimensions in blanks, contact us.

### Options

#### U-type end fitting ( - U)

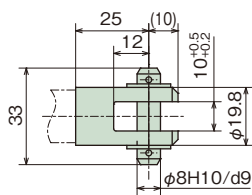

#### N-type end fitting ( - N)

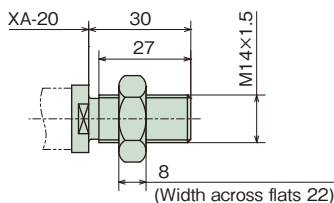

#### Trunnion fitting (LPE015-T)

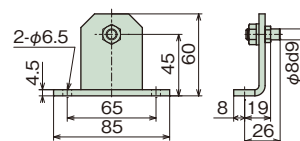

#### Foot fitting (LPE015-F)

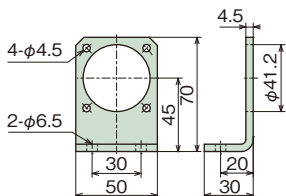

#### Trunnion fitting + foot fitting (LPE015-FT)



In the case of the above installation, model No. LPE15-FT comes with a set of trunnion and foot fittings.

# Motor direct coupling

## Dimensions table (□70 frame)

### LPES150FT

Mount code  
Stroke

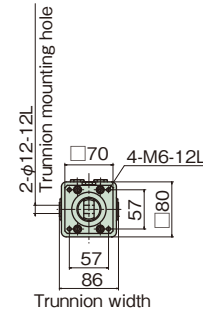
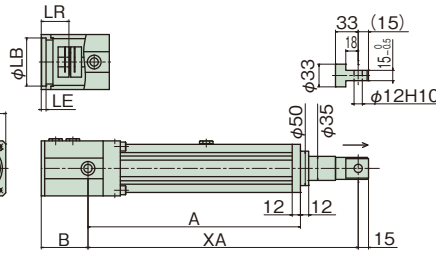
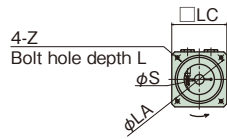

Stroke	A	XA	
		MIN	MAX
100	309	395	495
200	409	495	695
300	509	595	895
400	609	695	1095
500	709	795	1295
600	809	895	1495

マウントコード	LC	LB	LE	S	LR	LA	Z	L	B
E4H	80	50	8	14	30	70	M5X8L	-	68
G4K	80	70	5	16	40	90	M5X16L	14	77
G4L	80	70	5	19	35	90	M5X16L	9	72
G5K	80	70	5	16	40	90	M6X16L	14	77
G5L	80	70	5	19	40	90	M6X16L	14	77
G7L	80	70	5	19	35	90	M6X16L	9	72
Z9Z									

\* For dimensions in blanks, contact us.

Stroke	Mass
100	8.6
200	9.5
300	10.5
400	11.4
500	12.3
600	13.3

\* The above mass does not include the mass of the servomotor.

### LPES300FT

Mount code  
Stroke

Fig. 1

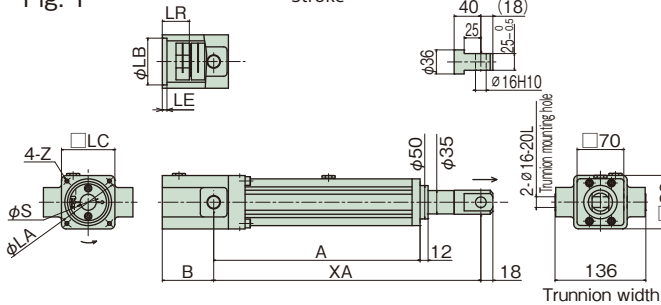
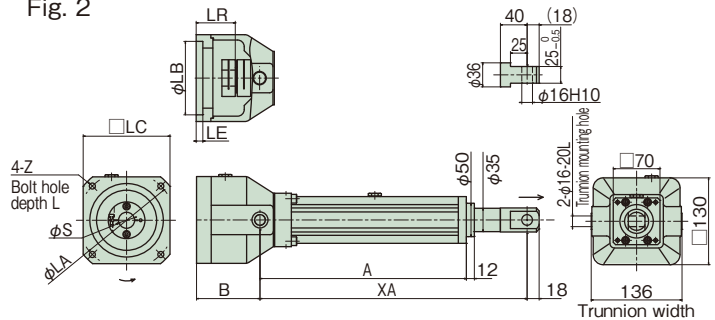

Fig. 2



Mount code	LC	LB	LE	S	LR	LA	Z	L	B	Drawing
G5K	80	70	5	16	40	90	M6X16L	-	77	1
G5L	80	70	5	19	40	90	M6X16L	-	77	
H1K	130	80	7	16	35	100	M6X7L	-	74	2
H2K	130	80	7	16	40	100	M6X7L	-	77	
H2L	130	80	22	19	55	100	M6X22L	-	92	
H2Y	130	80	12	24	45	100	M6X12L	-	82	
J2M	130	95	10	22	40	115	M8X10L	-	80	
J3Y	130	95	12	24	45	115	M6X12L	-	82	
J4M	130	95	12	22	45	115	M8X12L	-	82	
J4Y	130	95	12	24	45	115	M8X12L	-	82	
J5L	130	95	23	19	55	115	M8X10L	-	93	
J7Y	130	95	19	24	40	135	M8X19L	-	80	
J8Y	130	95	19	24	50	135	M8X19L	-	89	

Mount code	LC	LB	LE	S	LR	LA	Z	L	B	Drawing
K2L	130	110	10	19	40~41	145	M8X20L	6	79	2
K2M	130	110	10	22	40	145	M8X20L	6	79	
K3L	130	110	25	19	55~58	145	M8X20L	22	95	
K3M	130	110	25	22	55	145	M8X20L	22	95	
K3Y	130	110	25	24	55~58	145	M8X20L	22	95	
K6M	130	110	12	22	45	145	M8X20L	9	82	
K7M	130	110	37	22	70	145	M8X20L	34	107	
L1M	176	114.3	22	22	55	200	M12X19L	-	92	
Z9Z										

\* For dimensions in blanks, contact us.

Stroke	A	XA	
		MIN	MAX
100	309	400	500
200	409	500	700
300	509	600	900
400	609	700	1100
500	709	800	1300
600	809	900	1500

Stroke	Mass
100	14.3
200	15.2
300	16.1
400	17.1
500	18.0
600	19.0

\* The above mass does not include the mass of the servomotor.

## Options

LPES150	<b>U-type end fitting (-U)</b> 	<b>Bellows (-J)</b>  When bellows are equipped, flange mount is not available.	<b>Trunnion fitting (LPE025-T)</b> Mass: 0.6kg  Order the trunnion fitting separately from main body model No. without entering any symbol at the end of model No.
	LPES300	<b>U-type end fitting (-U)</b> 	<b>Bellows (-J)</b> 

## With precision planetary reducer

### Dimensions table (□70 frame)

#### LPES150R□T□□□□

Reduction gear ratio      Mount code  
Stroke

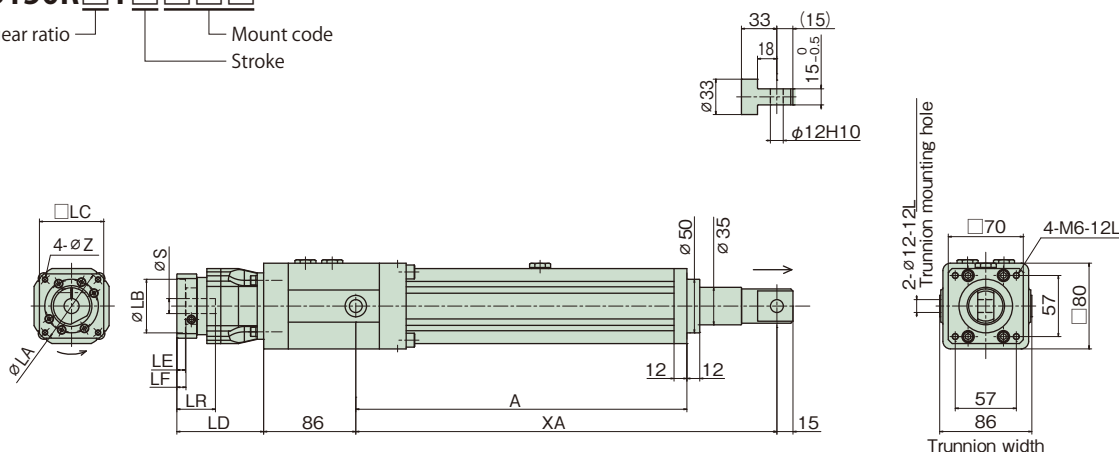

With PAT-B160

Mount code	LC	LB	LE	S	LR	LF	LA	Z	LD
A3D									
B3D	58	30	4	8	36	8.5	46	M4X9L	81
B4D									
E2C									
E2D									
E3D									
E3G	60	50	4	11	32	4.5	70	M4X9L	77
E3H	60	50	4	14	32	4.5	70	M4X9L	77
E4D	60	50	8	8	36	8.5	70	M5X10L	81
E4E	60	50	8	9	36	8.5	70	M5X10L	81
E4H	60	50	8	14	36	8.5	70	M5X10L	81
E5H									

Mount code	LC	LB	LE	S	LR	LF	LA	Z	LD
G1G									
G1H									
G1Z									
G5H	80	70	4	14	42	14.5	90	M6X12L	87
H1F	92	80	9	10	42	14.5	100	M6X12L	87
H1H	92	80	9	14	42	14.5	100	M6X12L	87
H1K	92	80	9	16	42	14.5	100	M6X12L	87
Z9D									
Z9H									

\* For dimensions in blanks, contact us.

Stroke	A	Unit: mm	
		MIN	MAX
100	309	395	495
200	409	495	695
300	509	595	895
400	609	695	1095
500	709	795	1295
600	809	895	1495

Stroke	Mass	Unit: kg	
		MIN	MAX
100	10.7		
200	11.6		
300	12.6		
400	13.5		
500	14.4		
600	15.4		

\* The above mass does not include the mass of the servomotor.

#### LPES300R□T□□□□

Reduction gear ratio      Mount code  
Stroke

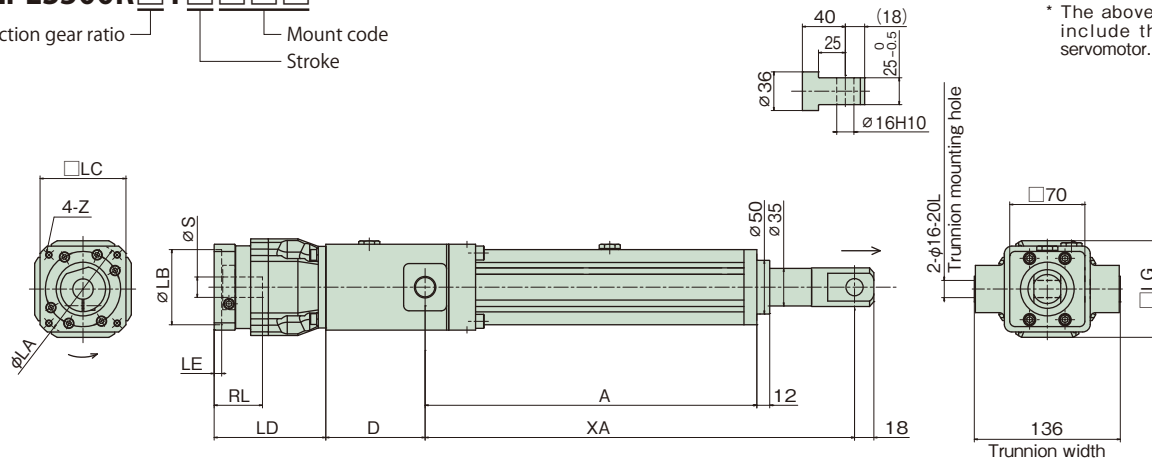

With PAT-B160

Mount code	LC	LB	LE	S	LR	LF	LA	Z	LD	LG	D
B3D	58	30	4	8	36	8.5	46	M4X9L	81	70	85
B4D											
E3G	60	50	4	11	32	4.5	70	M4X9L	77	70	85
E3H	60	50	4	14	32	4.5	70	M4X9L	77	70	85
E4E	60	50	8	9	36	8.5	70	M5X10L	81	70	85
E4H	60	50	8	14	36	8.5	70	M5X10L	81	70	85
E5H											
G1G											
G1H											
G1Z											
G4K											
G5H	80	70	4	14	42	14.5	90	M6X12L	87	70	85
G5K	80	70	4	16	42	14.5	90	M6X12L	87	70	85
H1F	92	80	9	10	42	14.5	100	M6X12L	87	70	85
H1H	92	80	9	14	42	14.5	100	M6X12L	87	70	85
H1K	92	80	9	16	42	14.5	100	M6X12L	87	70	85
J2K											
K2K											
Z9H											

With PAT-B220

Mount code	LC	LB	LE	S	LR	LF	LA	Z	LD	LG	D
G4L	80	70	5.5	19	43.5	6.5	90	M5X10L	102.5	90	93
G5L	80	70	7	19	45	8	90	M6X12L	104	90	93
H1Y	-	-	-	-	-	-	-	-	-	-	-
H4L	90	80	8	19	57	20	100	M6X12L	116	90	93
J3Y	100	95	4	24	47	10	115	M6X12L	106	90	93
J4L	100	95	8	19	57	20	115	M8X15L	116	90	93
J4M	-	-	-	-	-	-	-	-	-	-	-
J4Y	100	95	8	20	57	24	115	M8X15L	116	90	93
J7Y	120	95	7	24	58	21	135	M8X15L	117	90	93
K3L	130	110	18	19	60	23	145	M8X15L	119	90	93
K3Y	130	110	18	24	60	23	145	M8X15L	119	90	93
K5Y	-	-	-	-	-	-	-	-	-	-	-
K6M	-	-	-	-	-	-	-	-	-	-	-
K7M	-	-	-	-	-	-	-	-	-	-	-
Z9L	-	-	-	-	-	-	-	-	-	-	-

\* For dimensions in blanks, contact us.

Stroke	A	Unit: mm	
		MIN	MAX
100	309	400	500
200	409	500	700
300	509	600	900
400	609	700	1100
500	709	800	1300
600	809	900	1500

Stroke	Mass (with PAT-B160)	Mass (with PAT-B220)	Unit: kg	
			MIN	MAX
100	14.6	16.0		
200	15.5	16.9		
300	16.4	17.8		
400	17.4	18.8		
500	18.3	19.7		
600	19.3	20.7		

\* The above mass does not include the mass of the servomotor.



## Dimensions table (□105 frame)



Fig. 1

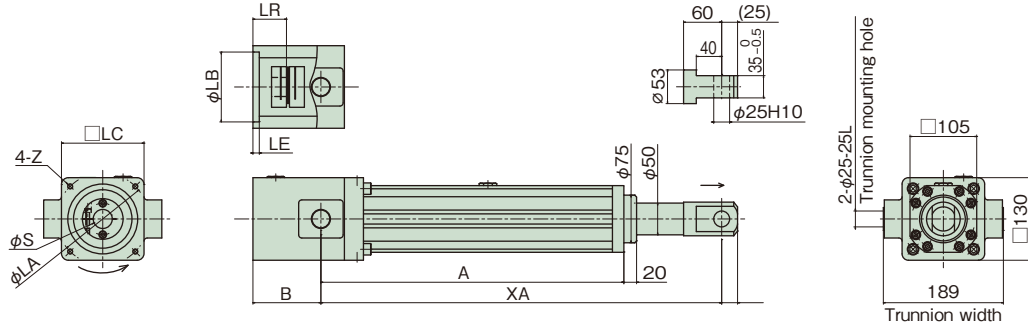
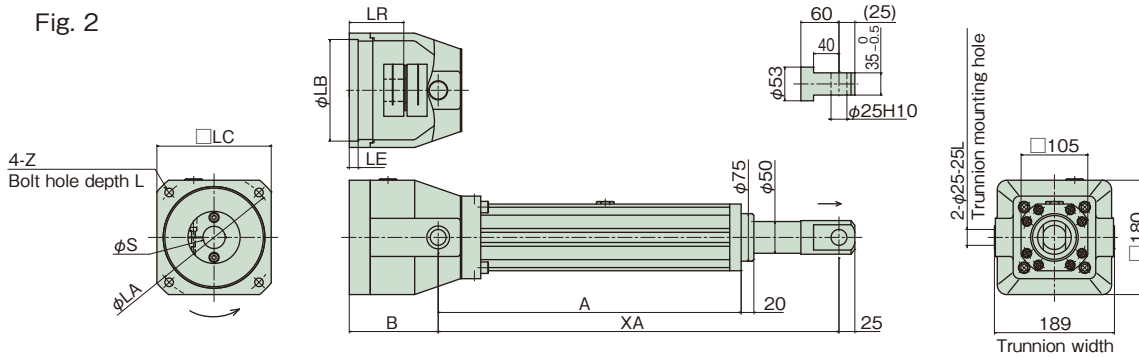

Fig. 2



Mount code	LC	LB	LE	S	LR	LA	Z	L	B	Unit: mm	
										Drawing	
H2Y	130	80	12	24	45	100	M6X12L	-	101	1	
J2M	130	95	10	22	40	115	M8X16L	-	96		
J3Y	130	95	5	24	45	115	M6X12L	-	101		
J4M	130	95	5	22	45	115	M8X16L	-	101		
J4Y	130	95	5	24	45	115	M8X16L	-	101		
K2M	130	110	9	22	40	145	M8X16L	-	96		
K2Z	130	110	9	26	40	145	M8X16L	-	96		
K3M	130	110	9	22	55~58	145	M8X16L	-	111		
K3P	130	110	9	28	55	145	M8X16L	-	111		
K3Y	130	110	9	24	55~58	145	M8X16L	-	111		
K4P	130	110	9	28	63	145	M8X16L	-	119	2	
K4Y	130	110	9	24	65	145	M8X16L	-	119		
K4Z	130	110	9	28(j6)	63	145	M8X16L	-	119		
K6M	130	110	5	22	45	135	M8X16L	-	101		
K6P	130	110	5	28	55	135	M8X16L	-	111		
K7M	130	110	9	22	70	145	M8X16L	-	124		
L1P	180	114.3	11	28	55	200	M12X25L	7	114		
L1Q	180	114.3	11	32	50	200	M12X25L	7	109		
L1R	180	114.3	21	35	65~70	200	M12X25L	17	124		
L1Z	180	114.3	21	28(j6)	65	200	M12X25L	17	124		
L2S	180	114.3	65	42	113	200	M12X25L	61	168		
L3R	180	114.3	10	35	79~80	200	M12X25L	29	136		
L3S	180	114.3	10	42	79	200	M12X25L	29	136		
M3P	180	130	17	28	60~65	165	M10X25L	-	120		
M4P	180	130	17	28	70	165	M10X25L	-	125		
N1S	200	180	6	42	85	215	M12X25L	33	140	2	
P2Q	220	200	6	32	65	235	M12X29L	-	124		
P2R	220	200	6	35	65	235	M12X29L	-	124		
P3R	220	200	6	35	70	235	M12X29L	-	124		
Z9Z											

Stroke	A	Unit: mm	
		MIN	MAX
200	537	680	880
300	637	790	1090
400	737	900	1300
500	837	1010	1510
600	937	1115	1715
800	1137	1335	2135
1000	1337	1555	2555

Stroke	Mass	Unit: kg
200	39.9	
300	42.9	
400	44.4	
500	46.7	
600	48.9	
800	53.9	
1000	57.9	

\* The above mass does not include the mass of the servomotor.

\* For dimensions in blanks, contact us.

## Options

### U-type end fitting ( - U)

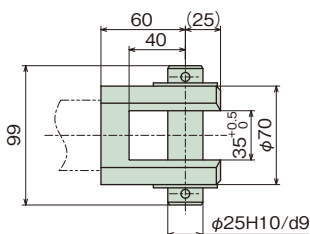

### Bellows ( - J)

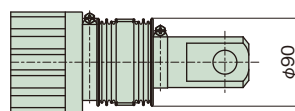

### Trunnion fitting (LPE400-T) Mass: 7.0kg

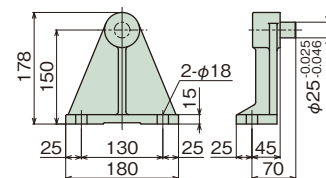

Order the trunnion fitting separately from main body model No. without entering any symbol at the end of model No.

With precision planetary reducer

Dimensions table (□105 frame)

LPES1500R□T□□□□□

Reduction gear ratio □ Mount code □ Stroke □

Fig. 1

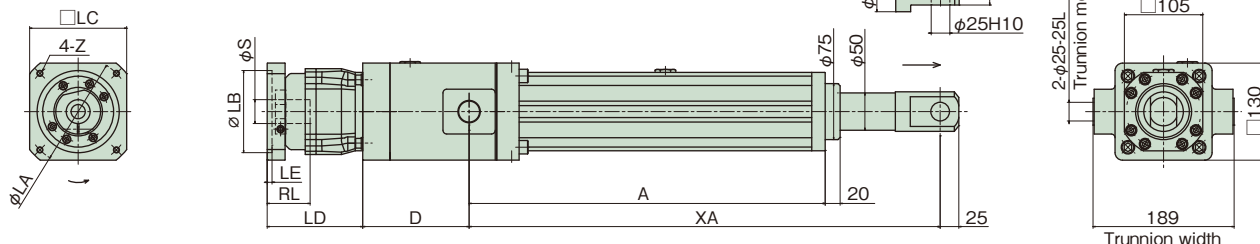
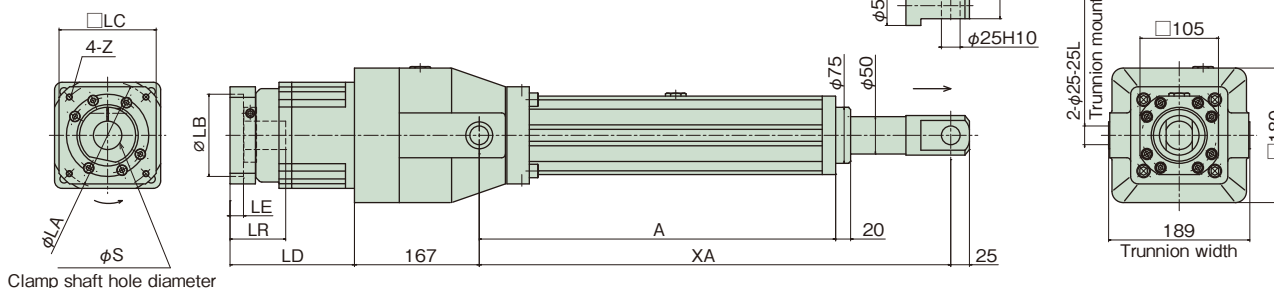

Fig. 2



Clamp shaft hole diameter

With PAT-B220

Mount code	LC	LB	LE	S	LR	LF	LA	Z	LD	D	Unit: mm Drawing
G4H										111	1
G4K	80	70	5.5	16	43.5	6.5	90	M5X10L	102.5	111	
G4L	80	70	5.5	19	43.5	6.5	90	M5X10L	102.5	111	
G5H	80	70	7	13	45	8	90	M6X12L	104	111	
G5K	80	70	7	16	45	8	90	M6X12L	104	111	
G5L	80	70	7	19	45	8	90	M6X12L	104	111	
G7L										111	
H1H	90	80	7.5	14	46	9	100	M6X12L	105	111	
H1K	90	80	7.5	16	46	9	100	M6X12L	105	111	
H1Y										111	
H4F	90	80	8	10	57	20	100	M6X12L	116	111	
H4H										111	
H4K	90	80	8	16	57	20	100	M6X12L	116	111	
H4L	90	80	8	19	57	20	100	M6X12L	116	111	
J2K	100	95	4	16	42	5	115	M8X15L	101	111	
J3Y	100	95	4	24	47	10	115	M6X12L	106	111	
J4L	100	95	8	19	57	20	115	M8X15L	116	111	
J4M										111	
J4Y	100	95	8	20	57	20	115	M8X15L	116	111	
J5L										111	
J7Y	120	95	7	24	58	21	135	M8X15L	117	111	
K3K										111	
K3L	130	110	18	19	60	23	145	M8X15L	119	111	
K3M	130	110	18	22	60	23	145	M8X15L	119	111	
K3Y	130	110	18	24	60	23	145	M8X15L	119	111	
K4Y										111	
K5Y										111	
K6M										111	
K7M										111	
L1M										111	
Z9L										111	
Z9M										111	

With PAT-B320

K3P	130	110	6.5	28	57.5	11	145	M8X15L	128	143	1
K4P	130	110	6.5	28	72.5	26	145	M8X15L	143	143	
K6P	-	-	-	-	-	-	-	-	-	143	
L1P	-	-	-	-	-	-	-	-	-	143	
L1Q	-	-	-	-	-	-	-	-	-	143	
M3P	150	130	9	28	67.5	21	165	M10X18L	138	143	
M4P	-	-	-	-	-	-	-	-	-	143	
P1P	220	200	6	28	57.5	11	235	M12X21L	128	143	
Z9P										143	
Z9Q										143	

With PAT-B400

L1R	176	114.3	6	35	82.5	26.5	200	M12X21	174.5		2
P2R	220	200	6	35	67.5	11.5	235	M12X21	159.5		

\* For dimensions in blanks, contact us.

Stroke	A	Unit: mm XA	
		MIN	MAX
200	537	680	880
300	637	790	1090
400	737	900	1300
500	837	1010	1510
600	937	1115	1715
800	1137	1335	2135
1000	1337	1555	2555

Stroke	Unit: kg		
	Mass (with PAT-B220)	Mass (with PAT-B320)	Mass (with PAT-B400)
200	39.1	42.1	56.4
300	42.1	45.1	59.4
400	43.6	46.6	60.9
500	45.9	48.9	63.2
600	48.1	51.1	65.4
800	53.1	56.1	70.4
1000	57.1	60.1	74.4

\* The above mass does not include the mass of the servomotor.

# Application Solution

## Glass substrate tilting equipment

A large glass substrate is tilted for transfer to the next process by this equipment.

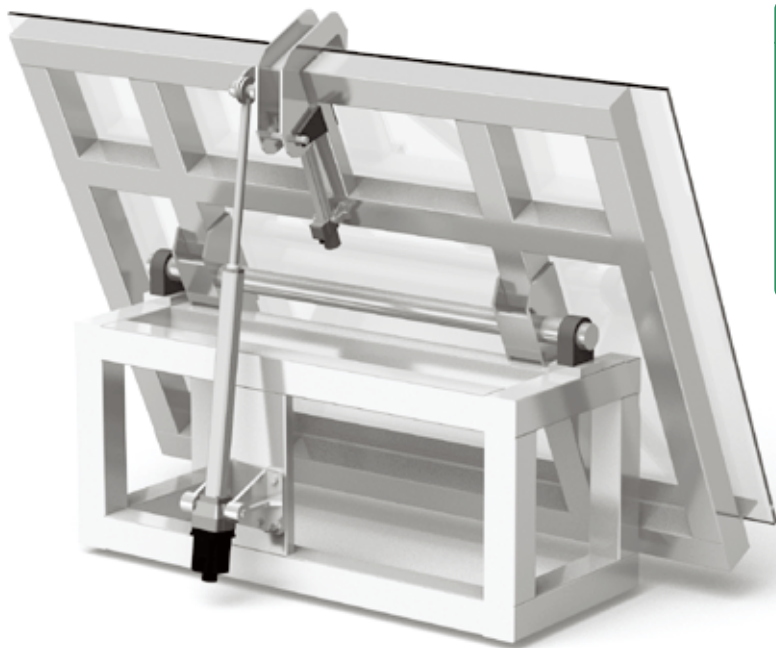

### Points for adoption

- ① **Swinging operation** .....  
Swinging operation can be performed because the servo cylinder is pin-connected with the equipment.
- ② **High-frequency operation** .....  
High-frequency operation with the frequency of starts 15 times/min. and a duty factor 50%ED can be performed.

## Film welding equipment

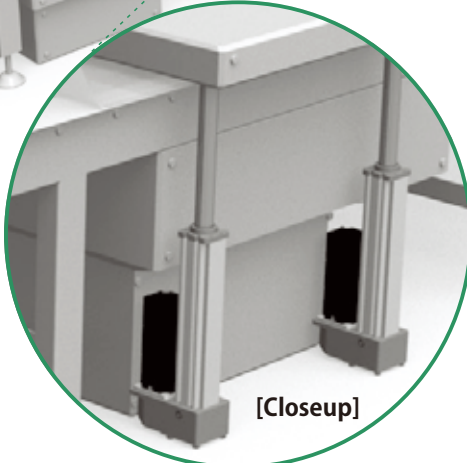
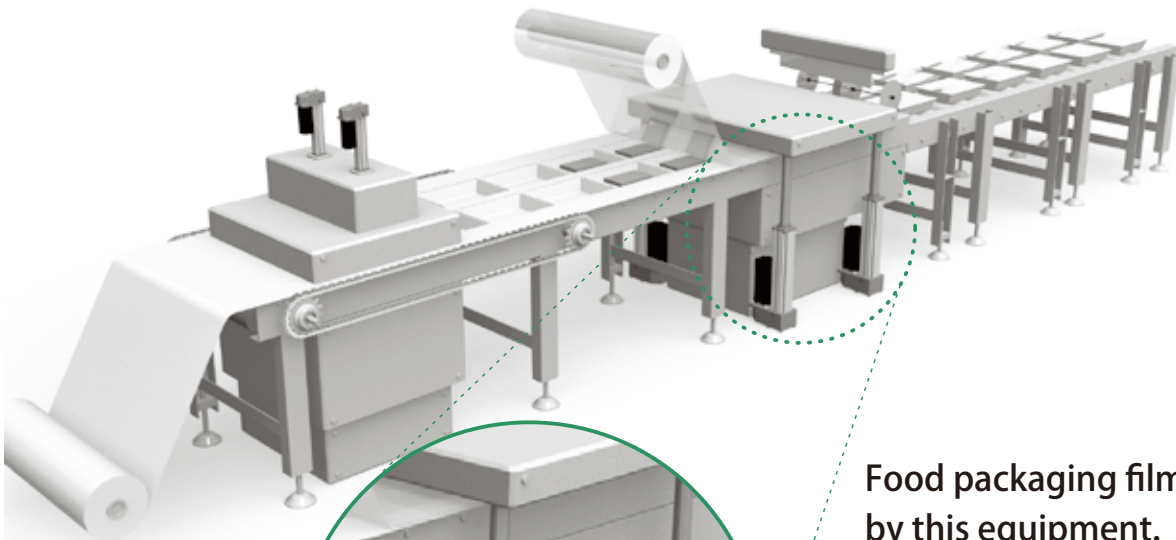

Food packaging films are welded by this equipment.

### Points for adoption

- ① **Clean operation** .....  
Clean with no oil leakage.
- ② **Synchronous operation** .....  
Two or more cylinders can be operated synchronously.

## Coating equipment

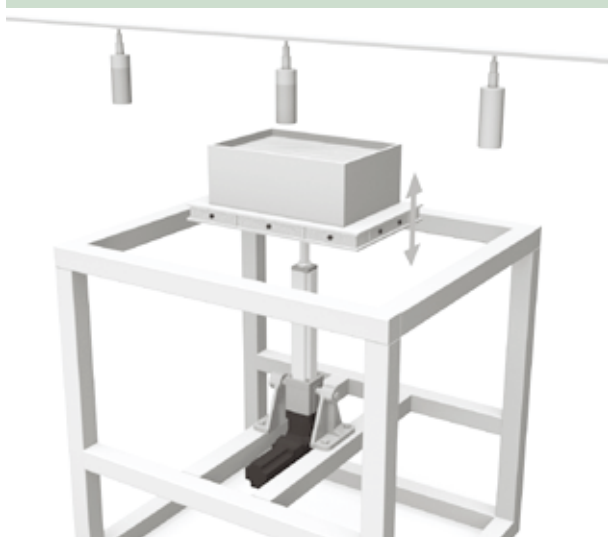

Workpieces are coated by moving up and down a tank containing a coating agent.

### Points for adoption

- ① **Accurate feeding operation** .....  
Accurate feeding operation is possible with the servo cylinder for a decrease in liquid level caused by the number of times of coating.
- ② **Shortening of overall length** .....  
In relation to the equipment, the overall length of the servo cylinder needs to be shortened, which is handled by an orthogonal type precision planetary reducer.

## Bonding equipment

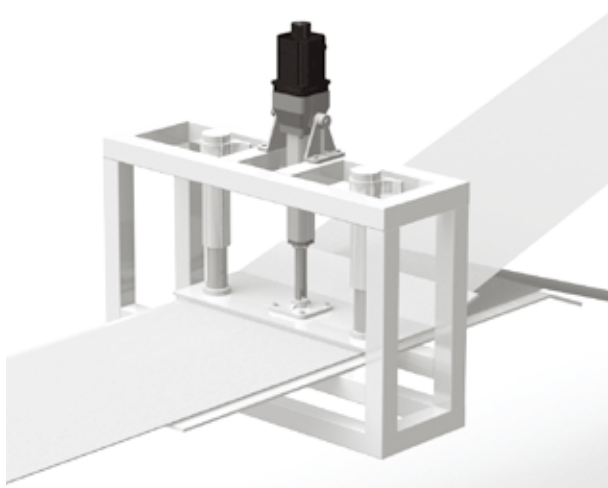

Two sheets of automotive parts are bonded by this equipment.

### Points for adoption

- ① **Accurate positioning** .....  
Fine positioning can be performed against jigs that differ in size according to sheet materials.
- ② **Torque control** .....  
Pressing force for bonding can be controlled.

## Workpiece erecting equipment



A glass substrate is erected for insertion into a cassette by this equipment.

### Points for adoption

- ① **Accurate positioning** .....  
The glass substrate can be erected to an accurate position by the servo positioning function.
- ② **Selectable servomotor manufacturer** .....  
A desired servomotor manufacturer can be specified according to control compatibility with peripheral equipment.

# Application Solution

## Frame assembling equipment

Aluminum frames are accurately assembled (press-fit) to a product in four directions by this equipment.

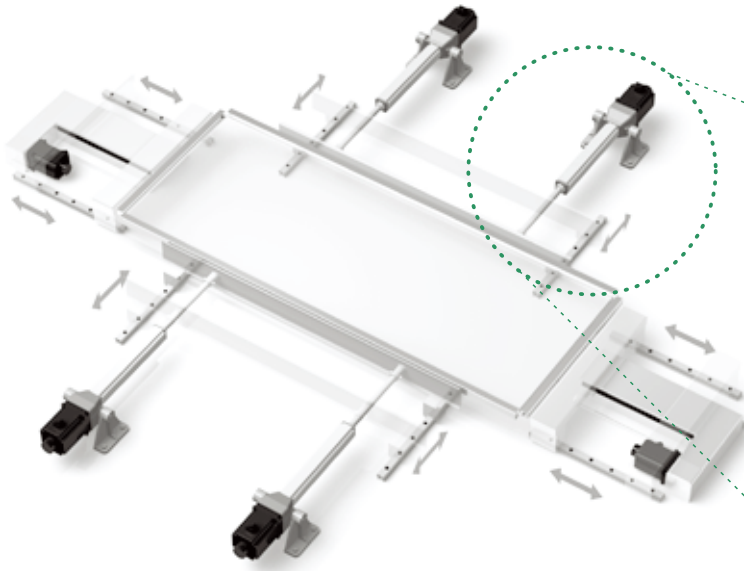

### Points for adoption

- ① **Torque control** .....  
At the time of assembly (press fitting), pressing force can be controlled as desired. (Pressing force differs according to product and shape.)
- ② **Wide-ranging speed variations** .....  
At the time of assembly (press fitting), operation is performed at low speed. At the time of return, operation can be performed at high speed, so that the cycle time can also be reduced.

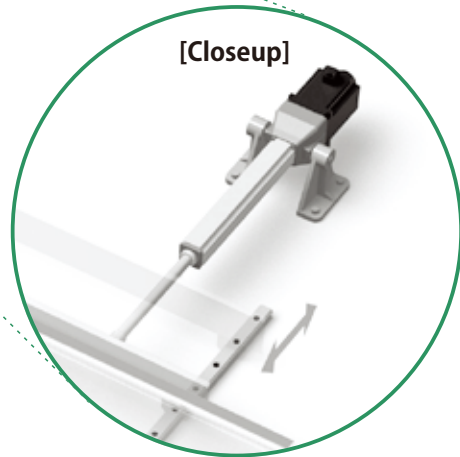

## Glass inspection equipment

Transferred glass is erected from 0 to 90 degrees and glass surfaces are inspected.

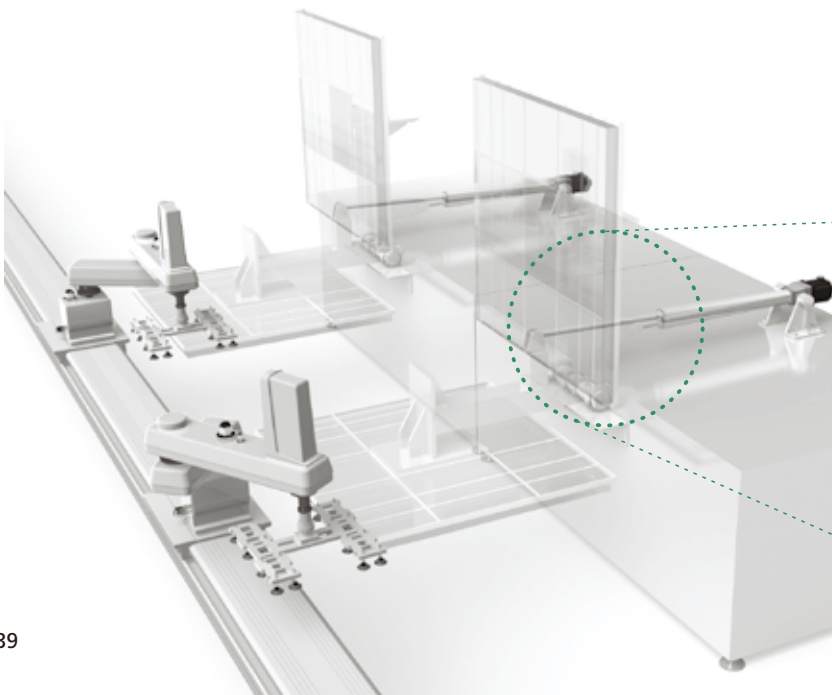

### Points for adoption

- ① **Support of large loads** .....  
Large loads of 8000N (up to 15000N) can be supported.
- ② **High-speed and high-precision positioning** .....  
Large loads can be positioned at a maximum speed of 333mm/s with high accuracy.

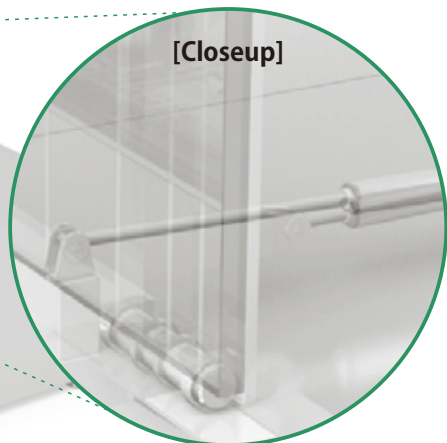



## Press-fitting equipment (press)



Diverse metallic parts are press-fit and assembled by this equipment.

### Points for adoption

- ① **Multiple-point positioning** .....  
Compared with air cylinders, positioning can be performed as desired.
- ② **Torque control** .....  
Pressing force is variable with workpieces and jigs.

## Injection equipment

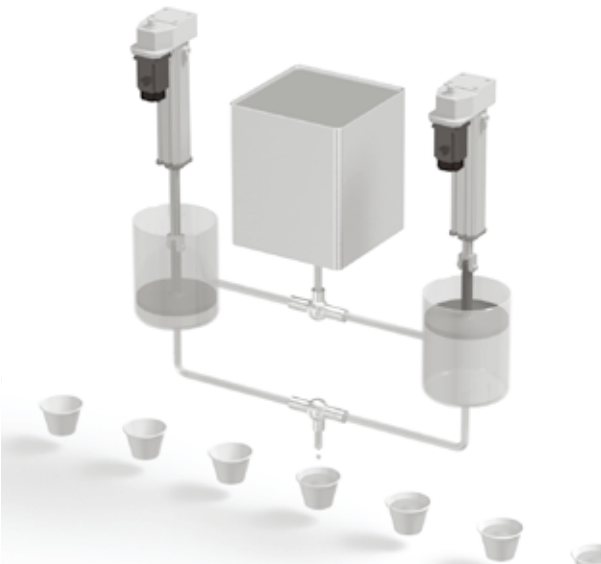

Diverse foods are quantitatively injected into special-purpose containers by this equipment.

### Points for adoption

- ① **Clean operation** .....  
Clean with no oil leakage.
- ② **Accurate speed control** .....  
Compared with conventional pump type, materials can be mixed in proportions and foods can be injected in accurately determined quantities by adjusting the speed of each piston.

## Equipment for arraying and pushing conveyed objects

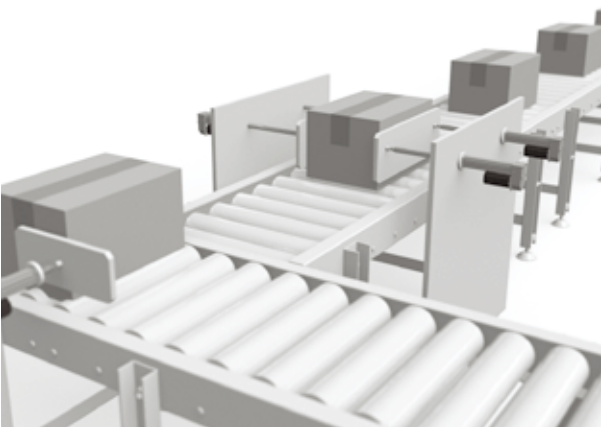

Conveyed objects are arrayed on the roller conveyor as desired and ejected by this equipment.

### Points for adoption

- ① **Accurate positioning** .....  
The servo positioning function allows desired arrays on the conveyor.
- ② **Torque control** .....  
Pressing force can be controlled according to the type of conveyed object.
- ③ **Flange mounting is possible depending on the installation space.**

# Servomotor mounting procedures (when installed by customer)

## Motor direct coupling

- 1 Prepare a servomotor. (An output shaft with/without keyway can be used.)
- 2 Set the servo motor with the coupling mounting hole of the motor flange facing upward. (□45 and □105 frames only)
- 3 Cleanly wipe away rust, dust, antirust oil, etc., of the motor shaft.
- 4 Loosen the clamp bolt of the coupling.
- 5 Remove the plug of the coupling case, turn the input shaft and set the clamp bolt head of the coupling to the position of the plug hole.
  - ⚠ For LPES30, there is a need to insert a torque wrench at an angle as shown below.
- 6 Smoothly insert the motor shaft to the coupling.
  - ⚠ If the motor is turned in the direction of rotation, the phase to the clamp bolt may be shifted.
- 7 Pay sufficient attention not to insert the motor shaft in a tilted manner.
- 8 After inserting the spigot facing part completely, attach it with the motor attaching bolt.
- 9 Using a torque wrench, tighten the clamp bolt of the coupling at the specified tightening torque.
- 10 Attach the removed plug to the coupling case.

\* Refer to the instruction manual for details.

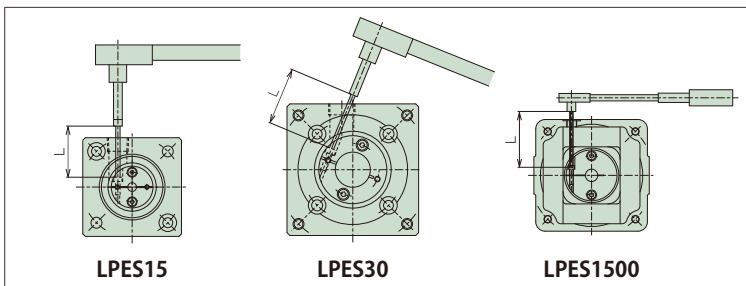

Model number	Coupling bolt size	Tightening torque N·m (kgf·m)	L mm
LPES15	M2	0.5 {0.04}	30
LPES30	M2.5	1.0 {0.10}	40
LPES150	M4	3.8 {0.39}	60
LPES300			70
LPES1500	M6	12 {1.22}	90

## With precision planetary reducer

### 1. When the motor shaft is round

- 1 Set the reducer with the motor mounting surface upward.
- 2 Cleanly wipe rust, dust, rust inhibitor, etc., off the motor shaft.
- 3 Remove the plug from the adapter, turn the input shaft, and align the bolt head with the position of the plug hole.
- 4 Check that the set bolt has been loosened with a hexagonal spanner, etc.
- 5 Smoothly insert the motor shaft in the input shaft hole. At this time, be aware that if the motor shaft is inserted in a tilted manner, galling with the shaft hole, etc., will occur, resulting in failure to mount properly.
- 6 After complete insertion of the spigot portion, completely fix the motor to the adapter at an appropriate tightening torque.
- 7 Tighten the set bolt of the input shaft with a torque wrench or the like at the tightening torque in the following table. At this time, be aware that if it is tightened at under the specified torque, looseness of the set bolt can lead to problems, such as a slip of the motor shaft. Do not apply Loctite and other anti-loosening agents to the set bolt. Proper tightening torque may not be obtained, resulting in insufficient tightening.
- 8 Attach the plug. Now, the motor setting is completed.

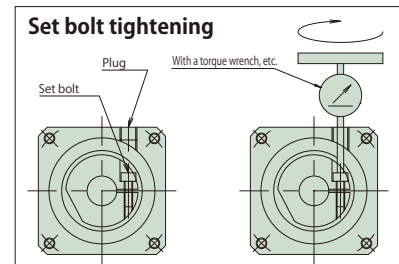

It is assumed that the clamp fit may slide with an unexpected impact. Give consideration to a separate safety mechanism for elevation drive, etc.

#### ● Set bolt tightening torque table

Reducer frame No.	Motor shaft diameter mm	Bolt size mm	Hexagonal wrench width across flats mm	Tightening torque N·m
PAT-B120	Single reduction	≦11	M3 ×0.5P ×8L	2.5
	Double reduction	≦11	M3 ×0.5P ×8L	2.1
PAT-B160	Single reduction	≦14	M4 ×0.7P ×12L	3
	Double reduction	≦11	M3 ×0.5P ×8L	2.5
PAT-B220	Single reduction	≦24	M5 ×0.8P ×14L	4
	Double reduction	≦14	M4 ×0.7P ×12L	3
PAT-B320	Single reduction	≦32	M6 ×1P ×16L	5
	Double reduction	≦24	M5 ×0.8P ×14L	4
PAT-B400	Single reduction	≦38	M8 ×1.25P ×20L	6
	Double reduction	≦32	M6 ×1P ×16L	5

\* The bolt tightening torque should be in the range of the above numerical values multiplied by 1.0 – 1.2.

#### ● Motor mount bolt tightening torque table

Bolt size mm	Hexagonal wrench width across flats mm	Tightening torque N·m
M3 ×0.5P	2.5	1.8
M4 ×0.7P	3	4.1
M5 ×0.8P	4	8.2
M6 ×1P	5	14
M8 ×1.25P	6	34

### 2. Mounting a keyed motor

A keyed motor shaft can be used in clamp type as is the case with a round shaft by removing the key.

Set the motor shaft keyway (D cut), each slit, and set bolt in position as shown in the illustration on the right-hand side. Other procedures for mounting to the reducer are the same as the round shaft's case.

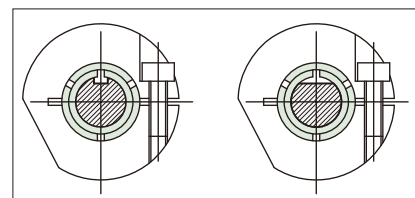

# ! WARNING

## ■ Cautions for selecting

- Anti-rod rotation mechanism is not provided with this cylinder. Turning force is generated to the rod owing to the thrust, make sure to perform prevention of rotation on the equipment side.  
The turning force placed on the rod at the time of the maximum thrust is as shown in the following table.

Model number	LPES15	LPES30	LPES150	LPES300	LPES1500
Rod turning force N·m	0.16	0.32	1.60	3.19	26.6
{kgf·m}	{0.016}	{0.031}	{0.16}	{0.33}	{2.72}

- Load holding mechanism is not provided with this cylinder in the cylinder main body. If a dangerous situation is anticipated during stoppage and when the product is broken, use a servomotor with a magnetic brake to hold the load, or provide a brake mechanism outside. It is same to use for elevating device or horizontal use and displacement is problem.
- Structurally, this power cylinder is an indoor type. Since there are problems, such as rust formation, store in a good indoor environment. Pay sufficient attention to humidity. Be aware that if it is installed in a place where the temperature changes rapidly, condensation will occur, causing failure or rust.
- Do not store or use in a corrosive atmosphere. Also, it cannot be used in a flammable atmosphere.
- Do not use in a place where there is no expectation for heat dissipation, such as in a closed container because doing so will cause failure.

## ■ Cautions for installation

- Use a trunnion mount or a flange mount (possible only for LPES150 or smaller) to install the main body. When used with oscillation, select an I-type or a U-type end fitting. If a lateral load is applied, provide a guide so as not to receive the direct lateral load or the bending moment.
- When it is installed with a flange mount, install it in the vertical direction. (Refer to the figure at the right.)  
\* When considering use of a flange mount for a type of LPES300 or larger, please contact TEM beforehand.
- For use in a static condition without swinging the cylinder, select ① Flange mount or ② Trunnion mount + foot mount. It can be installed either horizontally or vertically. (□45 frame only)
- When it is used horizontally for a long stroke, support the bottom part of the frame end as shown in the figure below. At this point, do not fix the frame and the supporting base.

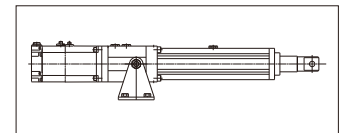

Trunnion mount

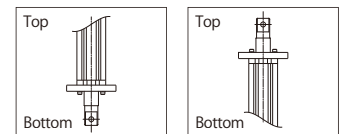

Flange mount

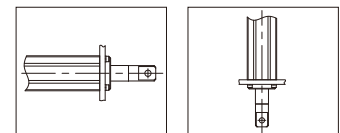

① Flange mount

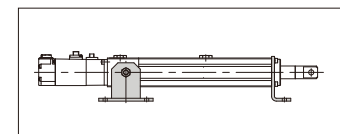

② Trunnion mount + foot mount

## ■ Cautions for use

- Overload protection mechanism is not provided with this cylinder in the cylinder main body, so provide protection against overvoltage, overcurrent, overload of the servo driver (servo amplifier). Additionally, manufacture the opposite side equipment of the power cylinder with a strength sufficient to withstand the maximum torque of the servomotor.
- Manual operation shaft is not provided with this cylinder for a structural reason, so adjust the cylinder position by operating the servo driver (servo amplifier) at very low speed.
- Daphne Eponex SR No.2 is applied to the screw shaft of this cylinder at the time of shipment, however, periodic lubrication is required. Refer to the table at the right for the lubrication amount of grease and the lubrication cycle.

The application amount of the grease is 10 – 15g per stroke of 100mm.  
And as grease for maintenance, JWGS100G is available (sold separately) from our company.

Frequency of operation	Lubrication cycle
1000 reciprocations/day or more	Every 1 month – 3 months
500 – 1000 reciprocations/day	Every 3 months – 6 months
100 – 500 reciprocations/day	Every 6 months – 1 year
10 – 100 reciprocations/day	Every 1 year – 1.5 years

- On the rod periphery, apply grease according to the lubrication cycle so that an oily film does not run out. Use the same grease as the one used for the screw.
- Determine the lubrication cycle according to the situation of operation.

## Power cylinder eco series CDS type

# New type power cylinders designed exclusively for press contact stop, and just fit for motorized air cylinders.

### Self-contained

Cylinders are exclusive to press contact stop. Overcurrent is detected to stop the motor automatically.

### Simple operation

Best suited to operation between two points, like air cylinders. No intermediate stop can be made.

### Simple wiring

Operation can be performed by simply connecting the three-phase power supply. No limit switch for stroke adjustment is required.

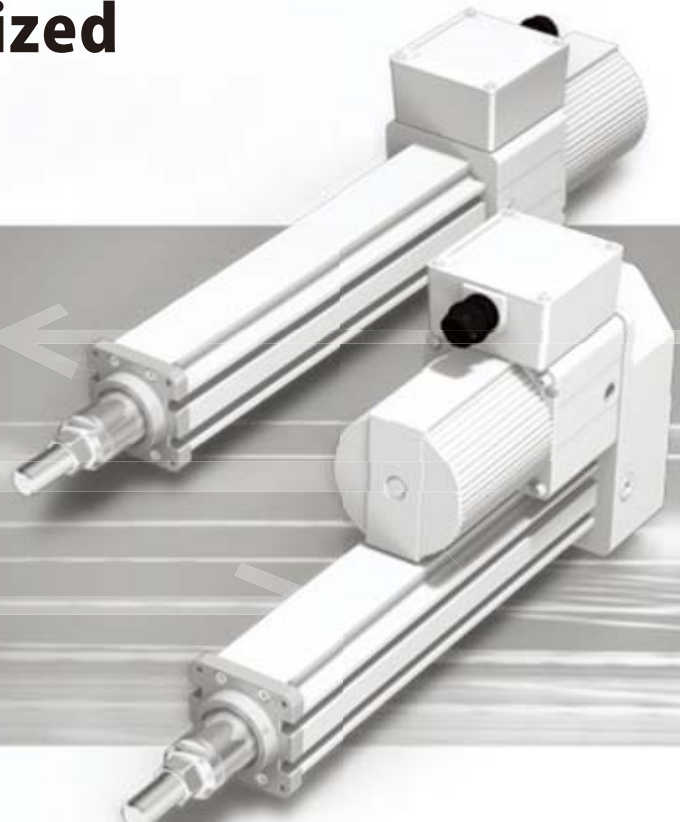

## Structure of SpeedMech

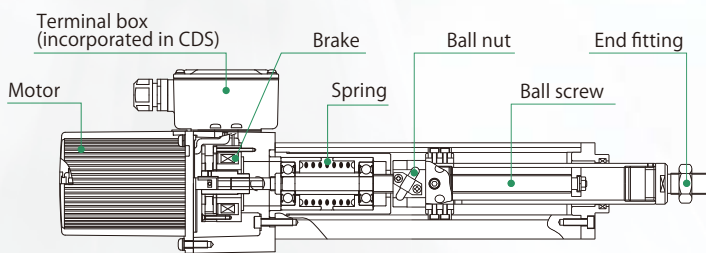

The basic structure of this electric cylinder is a combination of a screw and motor, which is the same as conventional power cylinders.

This SpeedMech enables the cylinder to stop without a limit switch by the combination of the spring built into the actuating part and the special board (CDS) mounted in the terminal box.

Also, compared with conventional electric cylinders, life is extended through the adoption of the first ball screw in this size and also the holding brake that is actuated after the motor is stopped.

## Operating principle of SpeedMech

1

### The cylinder extends.

The cylinder rod extends by an extend signal. The rod stops in the middle of stroke due to the stopper, etc., of the equipment on the other side. Or, the rod stops when reaching the stroke end.

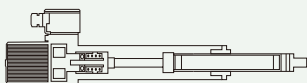

2

### The spring undergoes a deflection to lock the motor.

As the rod has stopped, the spring undergoes a deflection. At the same time, the motor is locked and the current value rises suddenly (overcurrent is generated).

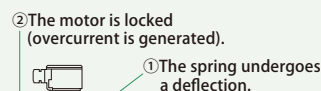

3

### The brake is actuated to stop the motor.

The rise in current value is detected by the CDS, and an operation command is sent to the brake. Subsequently, a stop command is sent to the motor to stop the motor. At this time, a pressing force is maintained by the brake force.

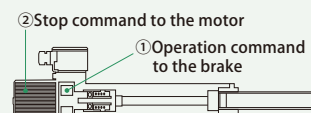

## Model No. designation

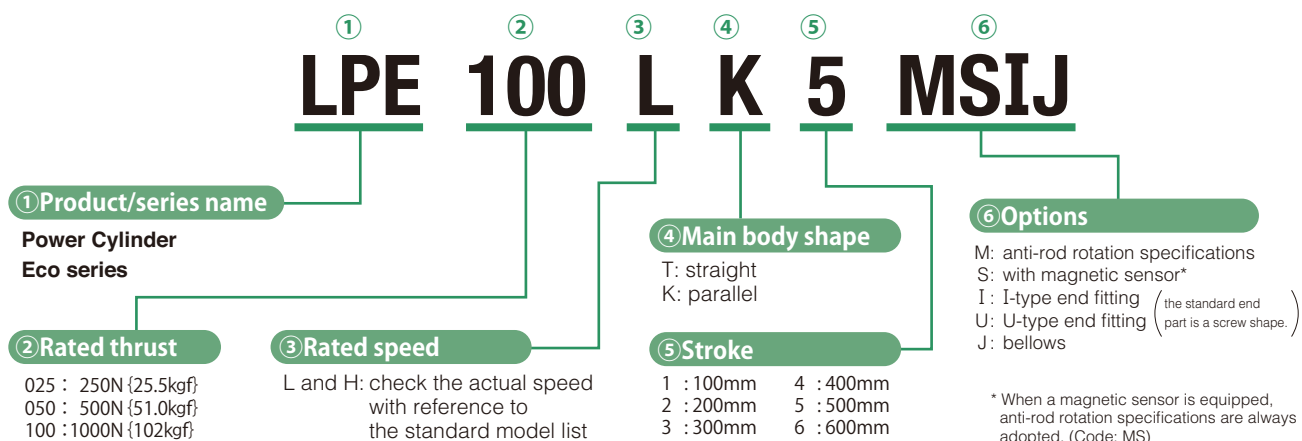

## Standard model list

Model number	Rated thrust N {kgf}	Rated speed mm/s 200/200/220V 50/60/60Hz	Motor output	Standard stroke mm
LPE025H	250 {25.5}	160/190/200	0.25N·m (50W or equivalent)	100
LPE050L	500 {51.0}	90/100/110	0.25N·m (50W or equivalent)	200 300
LPE050H	500 {51.0}	160/170/190	0.50N·m (90W or equivalent)	400
LPE100L	1.00k {102}	90/90/110	0.50N·m (90W or equivalent)	500 600

\* Pressing force varies depending on the machine type, and is two or three times the rated thrust.

## Standard environment of use

Model Environment	Indoor type
Ambient temperature	0~40°C
Relative humidity	45~85% (non-condensing)
Shock resistance value	0.5G or less
Installation altitude	1000m or lower above sea level
Ambient	Normally indoors*

\* Normally indoors means no exposure to wind, rain and water, and dust at a level inside an ordinary factory.

## Structure

### ■ Straight

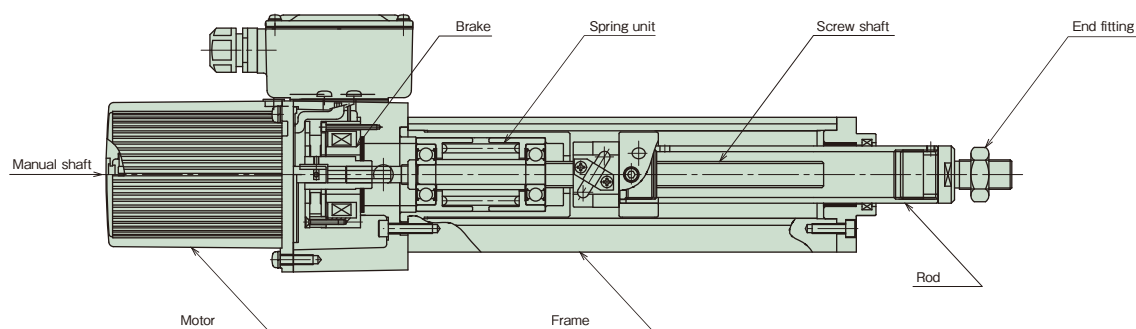

### ■ Parallel

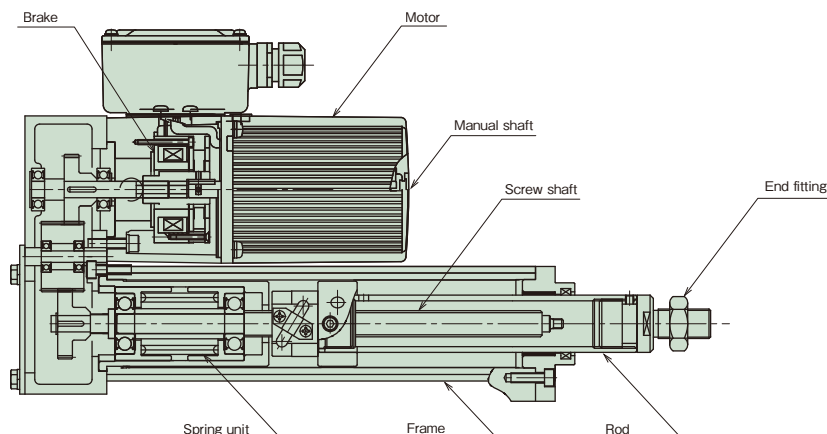



# Dimensions Table

## Straight

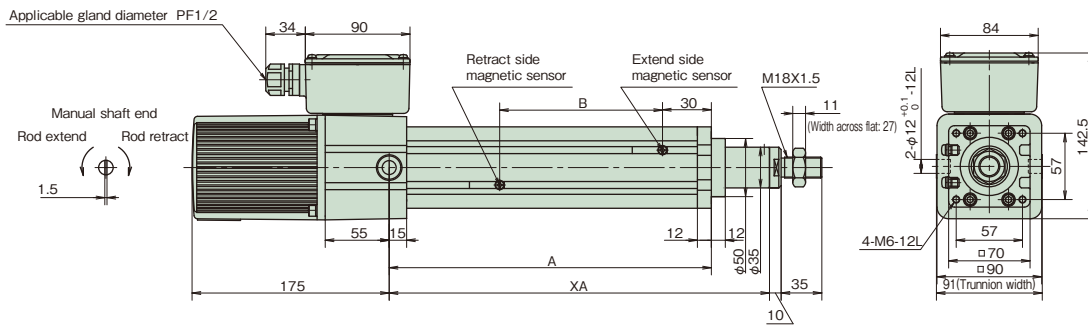

Unit: mm

Model	Main body shape	Stroke	A	B	XA		Approximate mass (kg)
					MIN	MAX	
LPE025H LPE050L LPE050H LPE100L	T	100	289	100	339	439	9
		200	389	200	439	639	10
		300	489	300	539	839	11
		400	589	400	639	1039	12
		500	689	500	739	1239	13
		600	789	600	839	1439	14

## Parallel

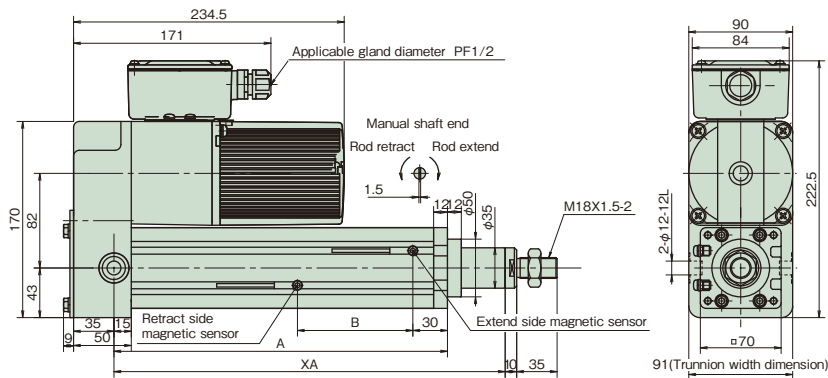

Unit: mm

Model	Main body shape	Stroke	A	B	XA		Approximate mass (kg)
					MIN	MAX	
LPE025H LPE050L LPE050H LPE100L	K	100	289	100	339	439	14
		200	389	200	439	639	15
		300	489	300	539	839	16
		400	589	400	639	1039	17
		500	689	500	739	1239	18
		600	789	600	839	1439	19

Options

I-type end fitting ( - I)

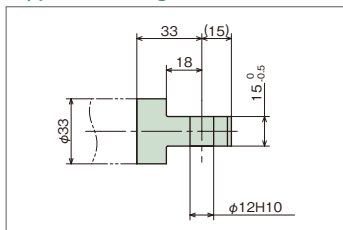

U-type end fitting ( - U)

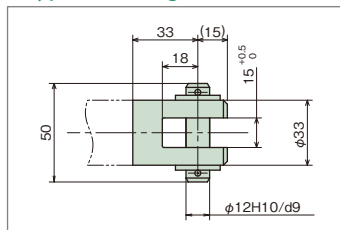

Bellows ( - J)

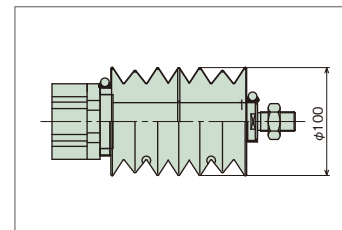

When bellows are equipped, flange mount is not available.

Trunnion fitting (LPE025-T)

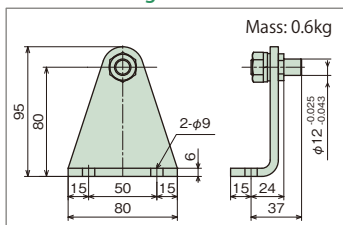

Order the trunnion fitting separately from main body model No. without entering any symbol at the end of model No.

Magnetic sensor ( - MS)

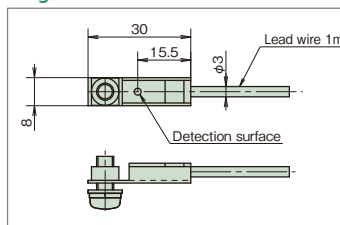

The magnetic sensor cannot be attached later. If it is necessary, place an order first. Types with a lamp or 2 wire type are also available. Refer to page 17.

Electric circuit

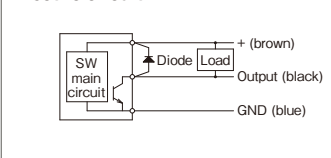

Magnetic sensor specifications

No contact switch (DC 3-wire system) (lead wire 1m)

Power voltage	5~26V DC
Consumption current	8mA MAX (24V DC)
Output specifications	15mA MAX (24V DC) Open collector output

Selection

Conditions of use required for selection

- Machine to use and application
- Thrust or load N { kgf }
- Stroke mm
- Speed mm/s
- Frequency of operation, starts/min.
- Power voltage, frequency
- Type of load of machine used
- Environment of use
- Hours of operation and annual number of operating days

Selection procedures

- Select the suitable model number from the standard model list (page16) based on thrust, speed and stroke.
- Check that the number of cycles of the selected cylinder is within the allowable range with reference to the table at the right. (Table 1)
- Check that the use conditions are satisfied with reference to the thrust – speed graph. (Figure 1)
- In the case of use for transportation, check that the mass of the conveyed material is within the allowable range. (Table 2)
- Select options as required.

Table 1 Allowable number of starts

Model number	Stroke mm	Thrust N			
		10	250	500	1000
LPE025H	100	15	12	—	—
	200	15	12	—	—
	300	10	10	—	—
	400	9	5	—	—
	500	8	4	—	—
	600	6	3	—	—
LPE050L	100	15	10	5	—
	200	8	8	5	—
	300	5	5	5	—
	400	5	5	3	—
	500	5	4	2	—
	600	4	4	2	—
LPE050H	100	15	12	10	—
	200	12	10	8	—
	300	10	10	6	—
	400	9	8	5	—
	500	8	7	4	—
	600	7	6	3	—
LPE100L	100	12	10	8	5
	200	8	8	8	5
	300	5	5	5	4
	400	5	5	5	3
	500	5	5	4	2
	600	4	4	4	2

Figure 1 Thrust – speed graph

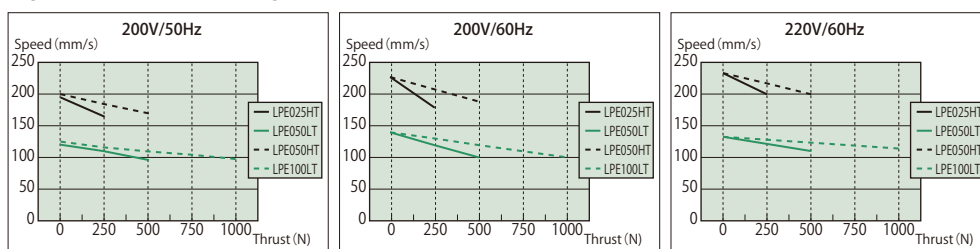

Table 2 Conveyed material mass in consideration of inertia

Model number	Horizontal	Vertical
LPE025HT	50	25
LPE050LT	100	50
LPE050HT	100	50
LPE100LT	200	100

\* The data of the above table 1 and figure 1 are numerical values at an ambient temperature of 20°C. The numerical values may vary depending on the ambient temperature and other conditions, so use them as a guide.  
\* Select a power cylinder of a sufficient thrust, allowing for a safety rate so that the loads used (static and dynamic) do not exceed the rated thrust.

# Application Solution

## Heat treatment furnace <for door opening and closing> Link structure

- Substitution for pneumatic cylinders

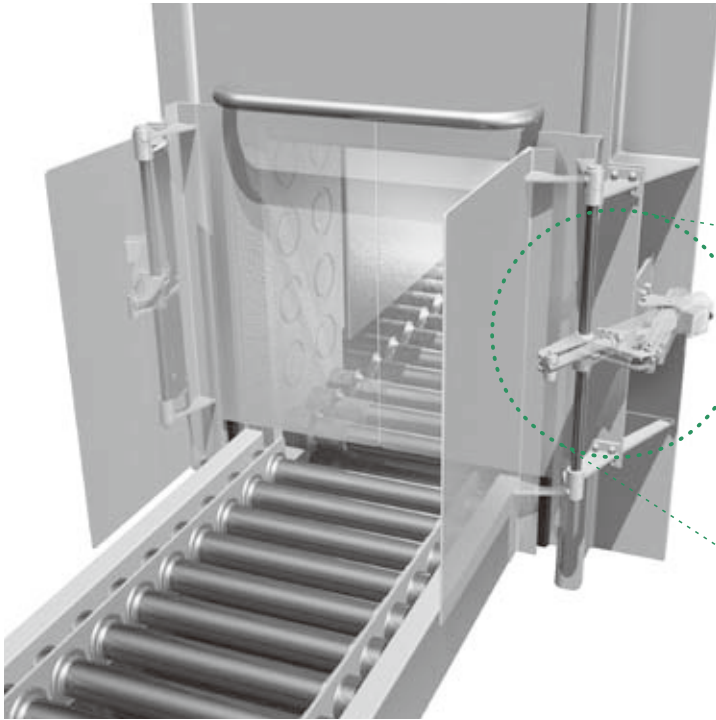

### <Door opening and closing at a transfer outlet>

For door opening and closing at a heat treatment furnace outlet for metallic parts, the SpeedMech enabling reliable closing and holding of pressing force has been adopted because of the problem of a pneumatic cylinder, which would conventionally be used: the door-closed state cannot be maintained due to air leakage. It is usable because the temperature around the cylinder is 40°C or less.

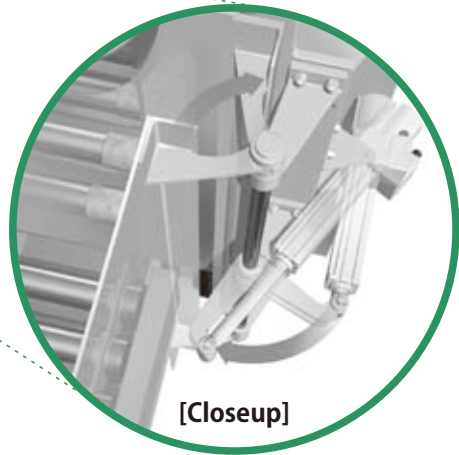

## Air duct <for damper opening and closing> Link structure

- Substitution for other companies' electric cylinders

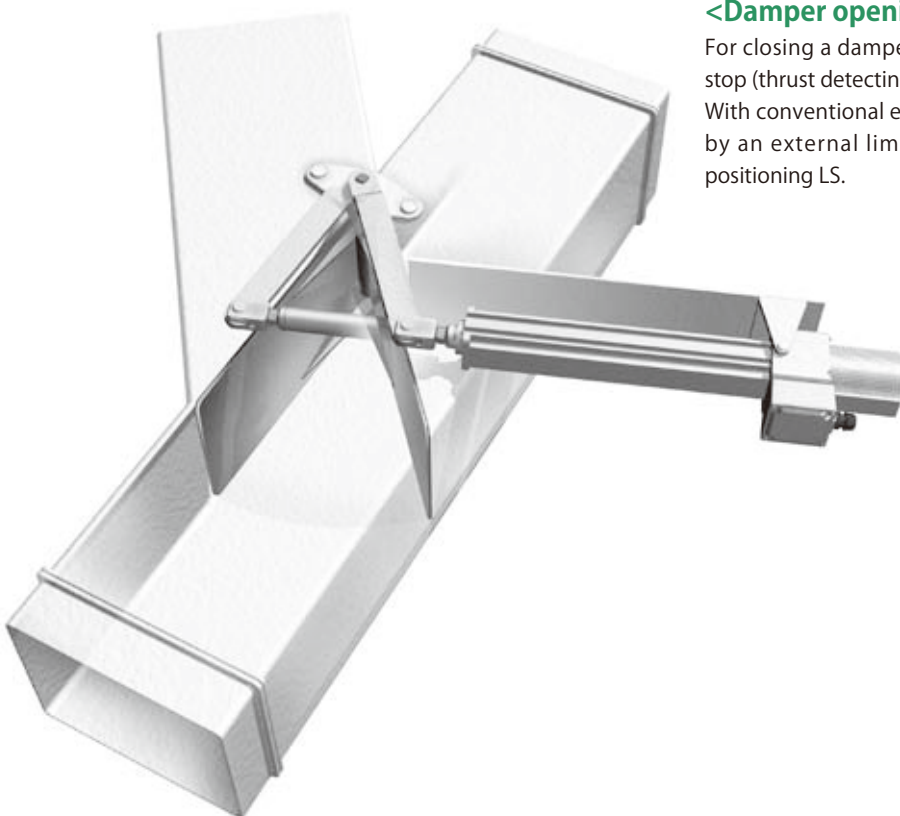

### <Damper opening and closing>

For closing a damper reliably, the cylinder needs a press contact stop (thrust detecting mechanism).

With conventional electric cylinders, stroke adjustments are made by an external limit switch, but the SpeedMech requires no positioning LS.

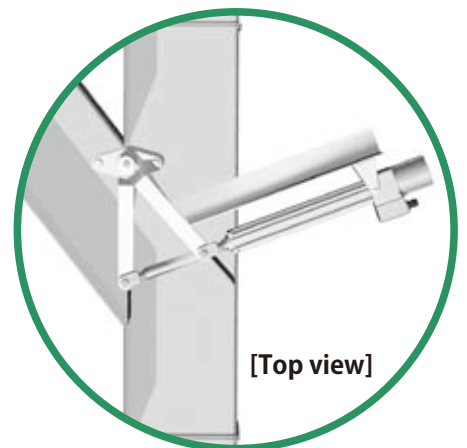

## Sorting <for roller conveyor>

Link structure

### ● Substitution for pneumatic cylinders

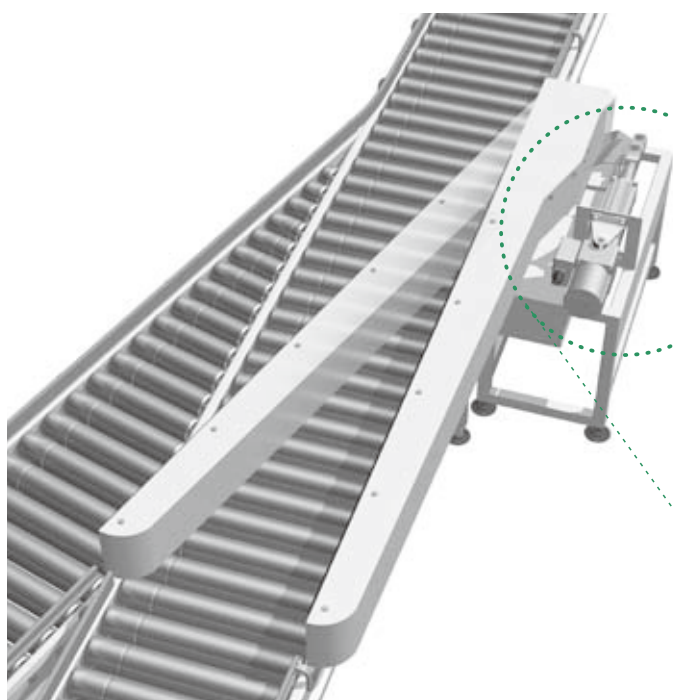

#### <Sorting (branching) of conveyed objects>

Since the destinations of conveyed objects are limited to two directions, reciprocations between two points are sufficient for the cylinder.

On the extending side, the cylinder extends to the stroke end and stops automatically. The same applies on the retracting side. Magnetic sensors are equipped because there is a need to remotely confirm the side on which the guide exists.

The SpeedMech and guide are a link mechanism.

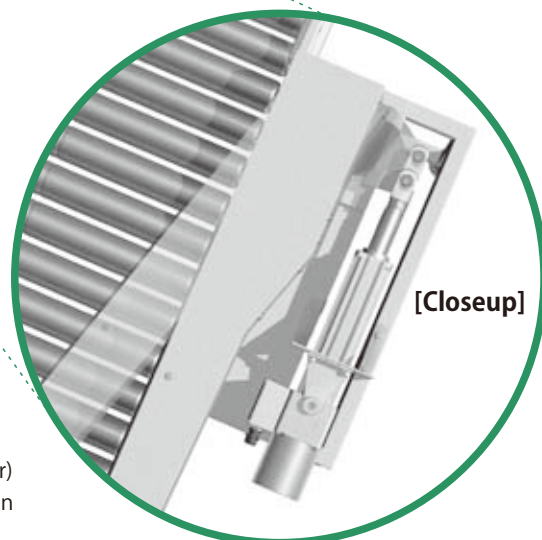

[Closeup]

#### <Roller conveyor>

Conveyed objects on the roller conveyor are guided by moving the guide (bar) for direction change according to their destinations. The SpeedMech has been adopted to drive this guide.

## Stopper

Link structure

### ● Substitution for pneumatic cylinders

A conveyed object on the conveyor is temporarily stopped by the stopper. When the cylinder rod fully extends, the stopper goes down, allowing the conveyed object to pass through. When the cylinder rod retracts to the backward limit, the stopper goes up to stop the conveyed object.

#### Points for adoption

- ① **Total cost reduction** .....  
Compared with air type, the total cost can be reduced. The running cost can also be reduced.
- ② **Environment-friendliness** .....  
Pneumatic type has adverse environmental effects caused by noise and oil mist generation.

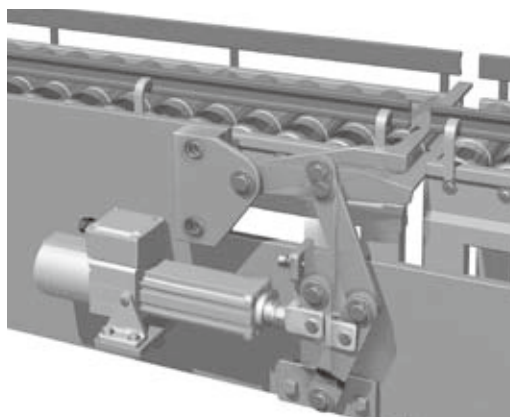

## Pusher

Direct-push structure

### ● Substitution for pneumatic cylinders

A specific object conveyed on the conveyor is pushed by the pusher to change the traveling direction. On the extending side, the cylinder extends to the stroke end to fully push the conveyed object with reliability. After the conveyed object is fully pushed, the cylinder rod is returned as quickly as possible.

#### Points for adoption

- ① **Simplified piping and wiring** .....  
In the case of air, piping and wiring become complicated because solenoid valves, speed controllers, etc., are required.
- ② **Cylinder speed** .....  
The speed, which is faster than that of conventional electric cylinders, cylinders virtually approaches that of pneumatic cylinders.

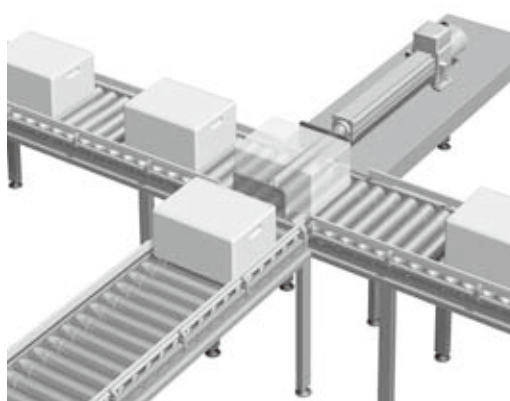



# Application Solution

## Lifter <for pin insertion to fix>

Direct-push structure

- Substitution for hydraulic cylinders

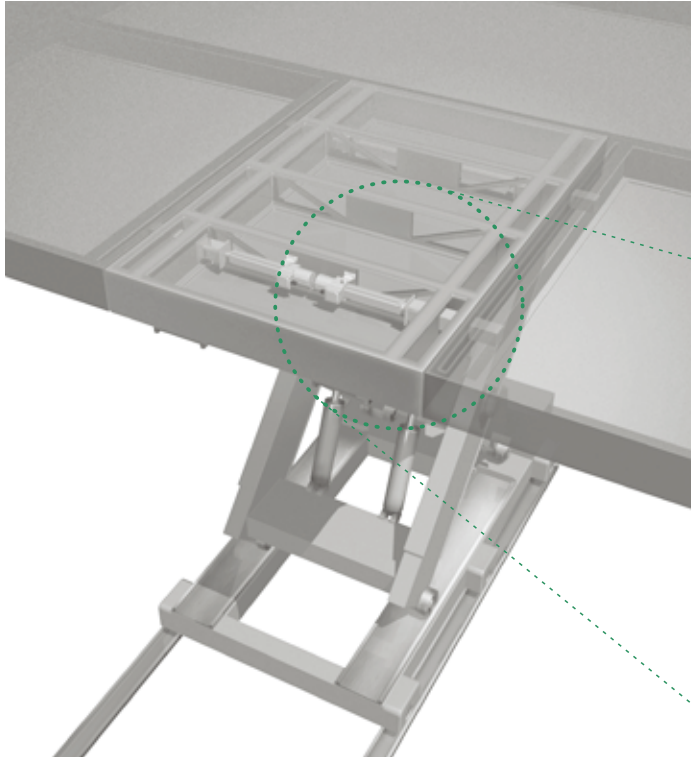

### <Table fall prevention>

On the extending side, the cylinder stops automatically when hitting against the wall on the other side. On the retracting side, it stops at the stroke end.

The cylinder rod position is always checked by outputting a signal with the optional magnetic sensor. Also, since the equipment on the other side has no anti-rotation mechanism, the optional rod anti-rotation specification has been adopted.

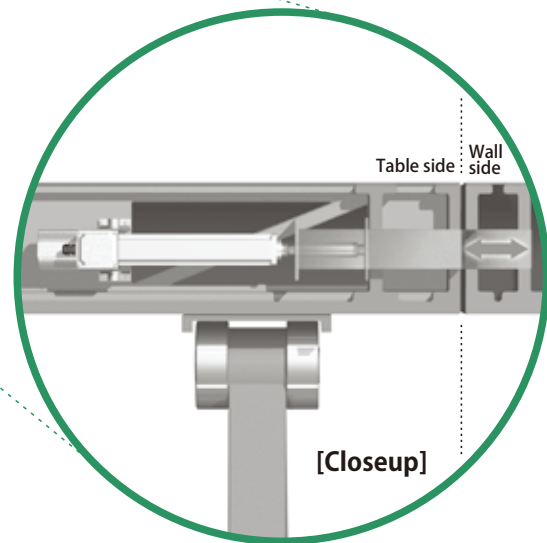

### <Table lifter>

Using a hydraulic cylinder for table elevation, there is danger that the table may fall due to oil leakage from the hydraulic cylinder during an attempt to fix at the ascent position. The SpeedMech has been adopted to fix the table position.

## Door opening and closing

Direct-push structure

- Substitution for pneumatic cylinders

Generally, pneumatic cylinders are adopted for opening and closing the automatic doors of machines, such as lathes, but there is an increasing demand for motorization in consideration of environmental aspects.

Also, wiring man-hours can be reduced compared with air piping and wiring.

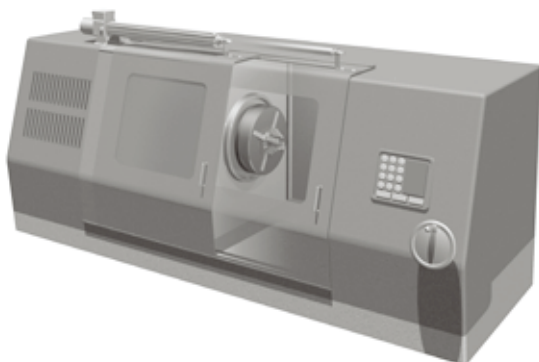

### Points for adoption

- ① **Environment-friendliness** .....  
Being free from noise and oil mist like pneumatic cylinders, the environmentally-friendly points have been well-recognized.
- ② **Simplified wiring** .....  
Compared with air piping, extra work and maintenance are not required because it can be actuated by the power line alone.



## Cutter

### Direct-push structure



#### ● Substitution for pneumatic cylinders

Bread dough in the hopper drops from the discharge spout, and the bread dough is cut by the opposing cylinders. Each cutter-equipped cylinder end stops just before the cutters collide with each other.

#### Points for adoption

- ① **Simplified piping and wiring** .....  
In the case of air, piping and wiring become complicated because solenoid valves, speed controllers, etc., are required.
- ② **Emergency stop** .....  
The cylinder brake is intended for holding, but in an emergency, it can urgently be stopped even in the middle of a stroke.

\* Cylinder end mounting flanges are not included as options. Also, centering is required for installation.

## Gate opening and closing

### Link structure



#### ● Substitution for hydraulic cylinders

When pouring fresh concrete into formwork, the gate (lid) is opened and closed.

The gate is closed by the cylinder in the pulling direction. If the fresh concrete has a high water content, there is a need to close the gate reliably in order to prevent leakage from the hopper. Conventionally, a hydraulic cylinder would be adopted.

#### Points for adoption

- ① **High speed** .....  
There is a need to close the gate quickly in order to secure a specified amount of pouring.
- ② **Reduction of piping and maintenance work** .....  
The hydraulic method requires time and effort, and cost for piping, and also maintenance should be performed.

## Shutter opening and closing

### Direct-push structure

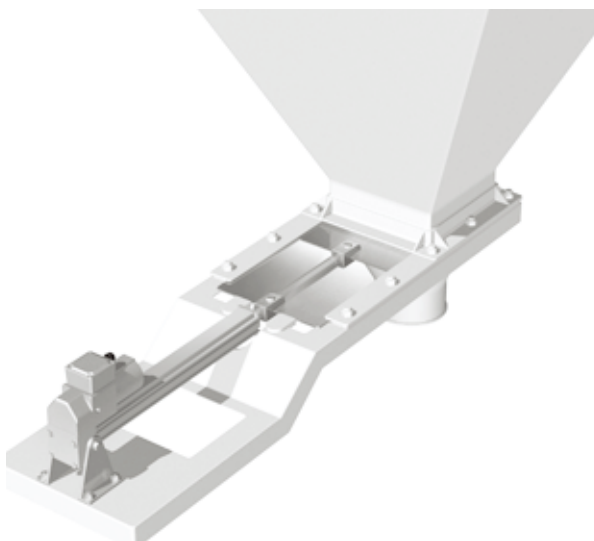

#### ● Substitution for pneumatic cylinders

In the process of conveying grains, a fixed amount of raw materials in the tank is dropped down and weighed. At that time, when the shutter is opened and closed, it should quickly be performed because the material drops at a high speed. Also, there is a need to close the shutter reliably and hold the pressing force.

#### Points for adoption

- ① **High speed** .....  
The shutter is closed quickly to prevent more than a fixed amount of raw materials from dropping.
- ② **Holding of pressing force** .....  
After the shutter is closed, the state needs to be held. (Press contact stop)

# ! WARNING

## Cautions for selecting

- No anti-rod rotation mechanism is attached to a cylinder with standard specifications. To use the end part freely, select the anti-rod rotation specifications (option).  
And when a magnetic sensor (option) is equipped, anti-rod rotation specifications are required.
- Refer to the allowable number table on page 46 to check that the number of the starts of selected cylinder is within the allowable range.
- If this cylinder is used for press or pull contact stopping, the strength of the equipment side must be 300% or more of the rated thrust.
- Structurally, this power cylinder is an indoor type. Since there are problems, such as rust formation, store in a good indoor environment. Pay sufficient attention to humidity. Be aware that if it is installed in a place where the temperature changes rapidly, condensation will occur, causing failure or rust.
- Do not store or use in a corrosive atmosphere. Also, it cannot be used in a flammable atmosphere.
- Do not use in a place where there is no expectation for heat dissipation, such as in a closed container because doing so will cause failure.

## Cautions for installation

- Install the main body using a trunnion or a flange mount.  
When it is used with oscillation using a trunnion mount, select an I-type or an U-type end fitting.
- If lateral load is applied, provide a guide so as not to receive lateral load or bending moment directly.
- When it is installed with a flange mount, install it in the vertical direction. (Refer to the figure at the right.)
- When it is used horizontally for a long stroke, support the bottom part of the frame end as shown in the figure below. Do not fix the frame and the supporting base.

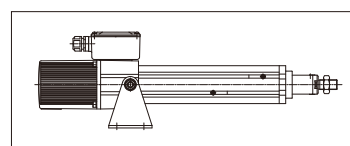

Trunnion mount

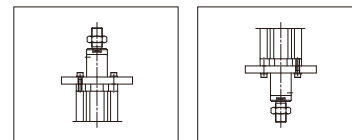

Flange mount

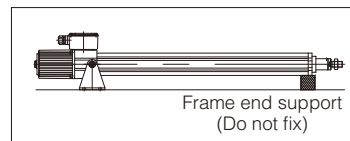

Frame end support  
(Do not fix)

## Cautions for use

- The motor stops when press or pull contact stops, however, on-the terminal block electricity is still being conducted. Never fail to cut off the main power source before working with the terminal box open.
- When adjusting the stroke manually, remove the cap bolt of the opposite load side of the motor, and turn the manual shaft with a flat-blade screwdriver or the like. However, use this only as an emergency since it is an operation with the brake working. And when operating manually, make sure to remove the load.
- Never use an inverter. This cylinder controls the press contact force by detecting overcurrent with the built-in CDS inside the terminal block and stopping the motor. If an inverter is used, the CDS circuit may be broken.
- Megger testing is prohibited for this cylinder. It may break the built in CDS. Remove all the terminals in the terminal block for megger testing of external circuits.
- Ensure the change over between extend and retract are at an interval of 0.2 seconds or more.
- The temperature around the motor may rapidly increase during operation and immediately after stopping. Do not touch around the motor part.
- Refer to the diagram below for connection and reference circuitry.

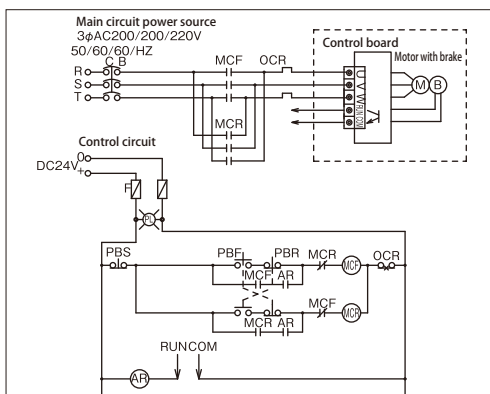

### NOTE:

- ① This is a single acting circuit diagram. The cylinder extends with the PBF and automatically stops with the press contact force at the stroke end or when hitting a wall in the middle of a stroke, etc. For retract, the cylinder retracts with the PBR and stops in the same manner as the extend side. Provide a circuit for allowing MCF and MCR to be turned OFF every time the cylinder stops.
- ② RUN and COM terminals can take out the output signal of the cylinder action.  
Open collector output: 50mA maximum 30V DC  
Coil current of the relay AR must be 50mA DC or less.
- ③ Use an electromagnetic contactor with a contact capacity of SC-0 made of a Fuji Electric or equivalent.

## Power Cylinder

# F series

### Thrust : 100N to 6.00kN {10.2kgf to 612kgf}

Small thrust type Power Cylinder, driven by DC (Battery) power source.

AC power source is also available with AC adaptor (Option).

Optimum for outdoor use, such as agricultural machine, multistory car parking.

#### ● Light weight, small type

Compact design where the operating part and the motor part are right angle.

#### ● Effective utilization of installation space

The hole of the clevis fitting is made in 2 directions at right angles to each other, the installation method can be selected from 4 directions so that it does not interfere with machine, etc.

#### ● Versatile power source

The DC power source type (12V DC, 24V DC) is standard. By using the AC adapter (sold separately), it can also be used with an AC power source. (LPF010, 020, 040 types)

#### ● Wide variety of options

Various options are available in comparison to the conventional type.

- Stroke adjustment external limit switch
- Bellows
- Position detection unit (internal limit switch, potentiometer)
- Overload detection unit



## Model No. designation

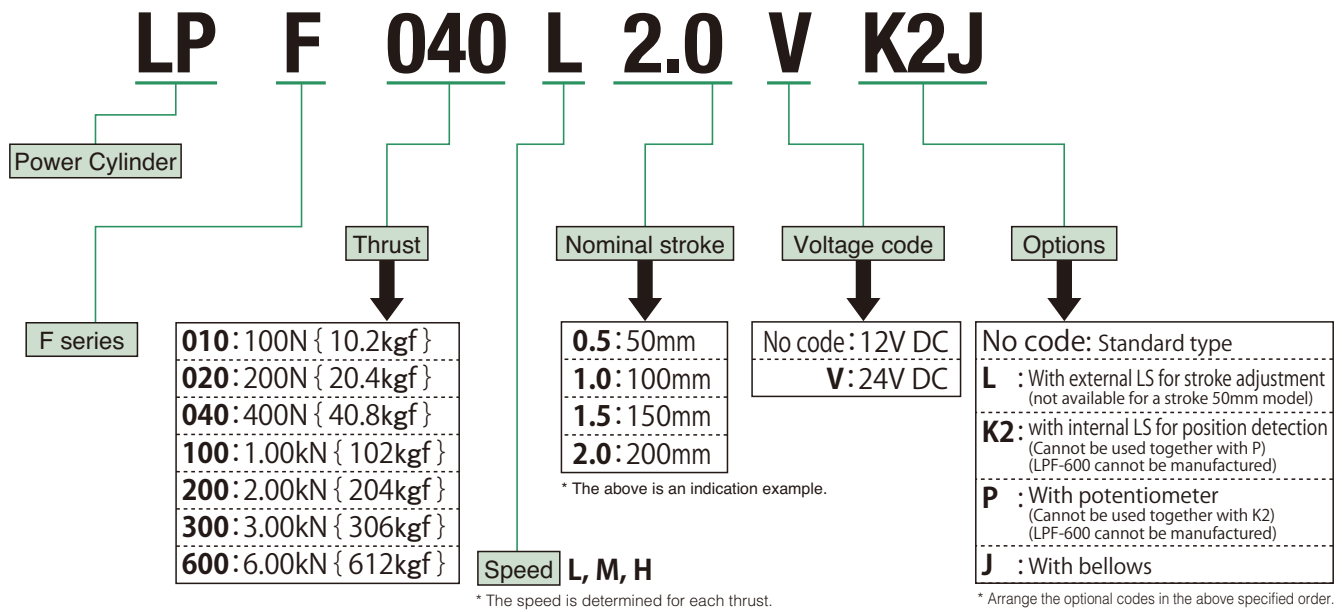

## Standard model list

Model number		Rated thrust	Stroke	Rated speed	Power source	Rated load current	Locked rotor current
		N	mm	mm/s	V	A	A
LPF010H	0.5	100	10.2	54	12 DC	3.2 (1.6)	16.7 (7.5)
	1.0						
	1.5						
	2.0						
	3.0						
LPF020M	0.5	200	20.4	24	12 DC	3.2 (1.6)	16.7 (7.5)
	1.0						
	1.5						
	2.0						
	3.0						
LPF040L	0.5	400	40.8	15	12 DC	3.7 (1.8)	16.7 (7.5)
	1.0						
	1.5						
	2.0						
	3.0						
LPF100H	0.5	100k	102	30	or 24 DC	18 (10)	63 (52)
	1.0						
	1.5						
	2.0						
	3.0						
LPF200M	0.5	200k	204	18	12 DC	22 (11)	63 (52)
	1.0						
	1.5						
	2.0						
	3.0						
LPF300L	0.5	300k	306	9	12 DC	22 (11)	63 (52)
	1.0						
	1.5						
	2.0						
	3.0						
LPF600L	1.0	600k	612	8	12 DC	20 (10)	63 (52)
	2.0						
	3.0						
	4.0						
	5.0						
	6.0						

Note) 1. In the case of 24V DC, V is attached at the end of the model number.  
 2. The numerical value in parentheses is an electric current value at the time of 24V DC.  
 3. Use a power source with a sufficient capacity in consideration of the locked rotor current.

## Motor specifications

Model	Item	Voltage	Output	Rated time
		V	W	
LPF010 H		12	29	5 minutes
		24		
		24		
LPF020 M		12	160	5 minutes
		24		
LPF040 L		12	160	5 minutes
		24		
LPF100 H		12	160	5 minutes
		24		
LPF200 M		12	160	5 minutes
		24		
LPF300 L		12	160	5 minutes
		24		
LPF600 L		12	160	5 minutes
		24		

## Standard use environment

Environment	Model	Outdoor type
Ambient temperature		-5°C~40°C
Relative humidity		85% or less (no dew condensation)
Shock resistance value		1G or less
Installation altitude		1000m or lower above sea level
Atmosphere		Normally outdoors

- 1) If used below the freezing point, the characteristics of the cylinder (current value, speed) may change from the influence of grease.
- 2) Cylinders with bellows are recommended in an excessively dusty location.
- 3) All models are totally enclosed structures so that they can be used normally outdoors, however, when exposed to constant adverse conditions such as water, steam and snow accumulation, an appropriate cover is required. When using at 40°C or higher, always protect with a heat insulating cover, etc. Never use in a flammable atmosphere. Otherwise it may cause an explosion and fire. In addition, avoid using in a location where vibration or shock exceeding 1G is applied.
- 4) For use in a misty atmosphere, contact us.

# Structure

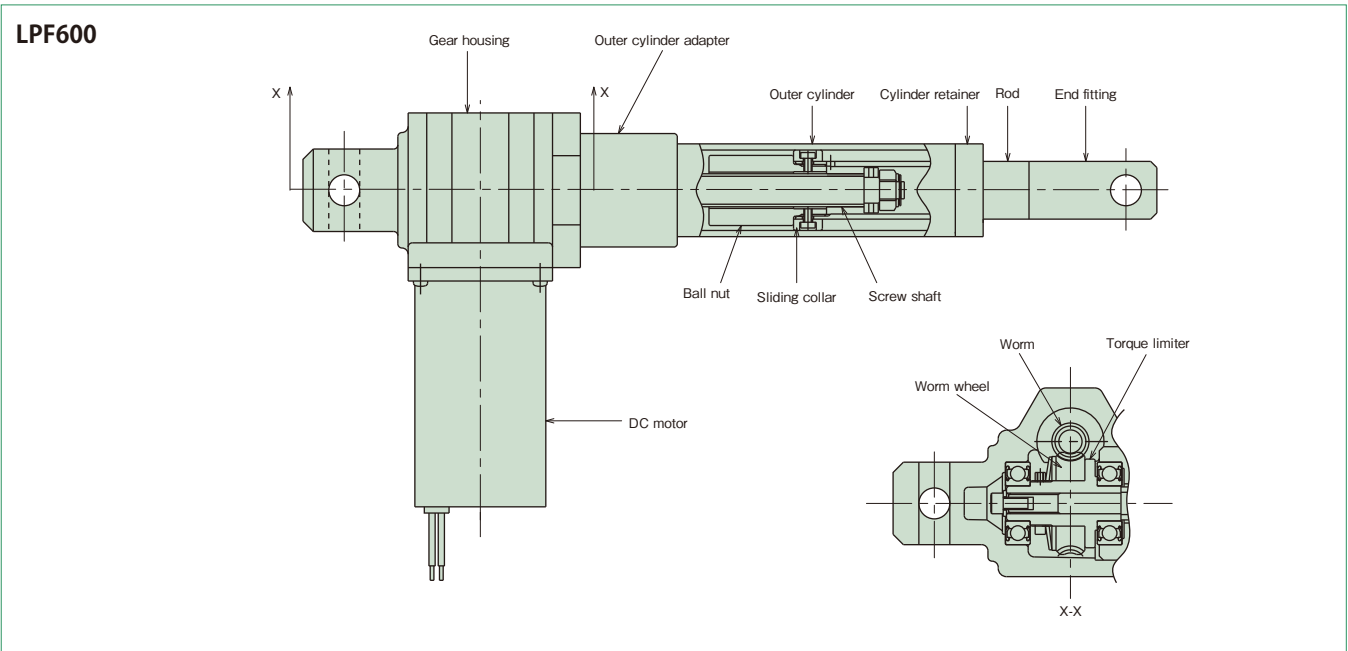
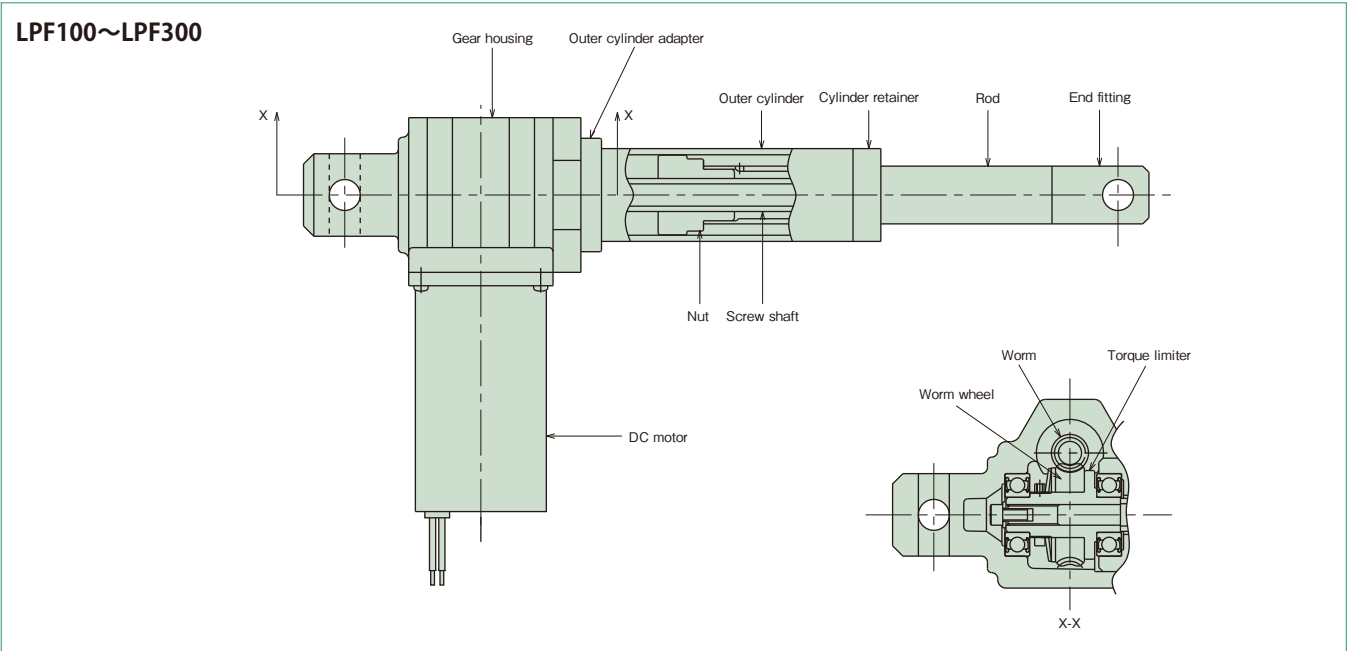
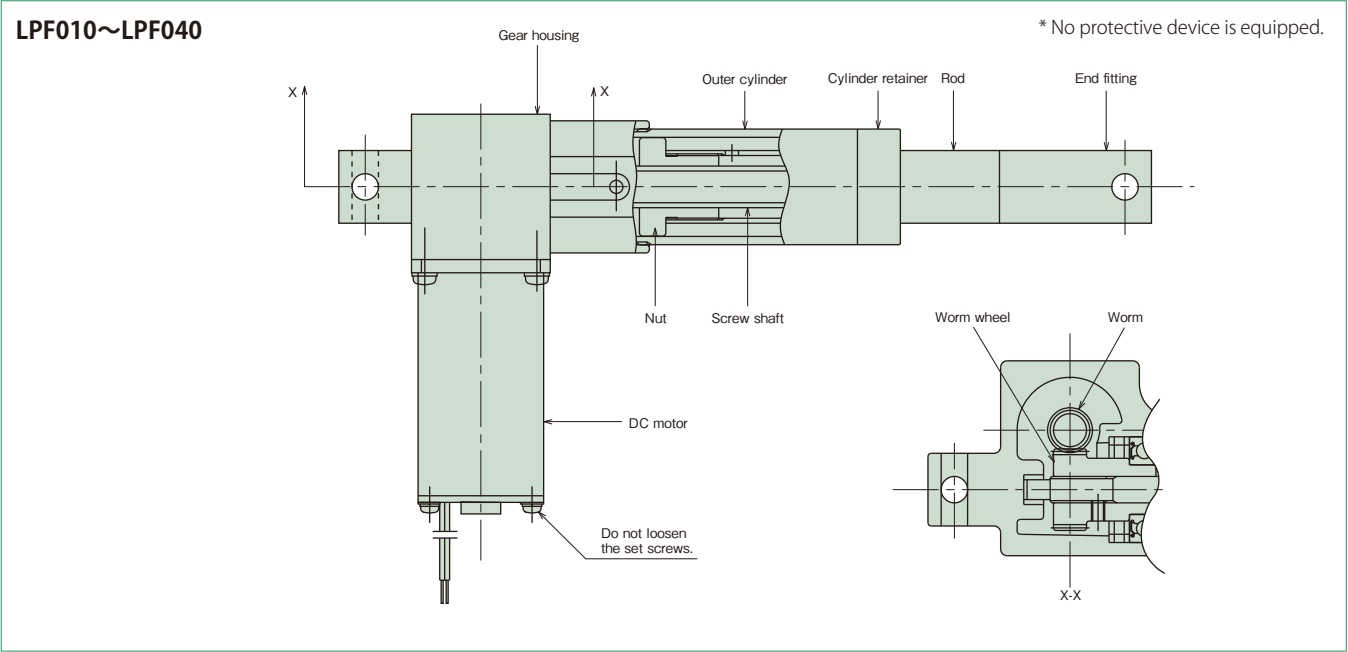



## Selection

### Operating conditions required for selection

- |                                 |               |   |
|---------------------------------|---------------|---|
| 1. Used machine and application | 3. Stroke mm  | 5. Frequency of operation, number of start/min. |
| 2. Thrust or load N { kgf }     | 4. Speed mm/s | 6. Power voltage, frequency                     |

### Selecting procedures

1. Select a suitable model number based on the thrust or load N { kgf }, stroke mm, speed mm/s.
2. Use the cylinder at an allowable operating frequency 2 times/min., allowable duty factor: 25%ED (5 minute basis), as for the frequency of operation.

The Working time rate is a ratio of the operating time per 5 minutes on a 5-minute basis.

$$\text{Working time rate (\%ED)} = \frac{\text{Operating time of 1 cycle}}{\text{Operating time of 1 cycle} + \text{dwell time}} \times 100\%$$

### Duration of life as a guide

Duration of life is 15,000 reciprocations, as a guide.

\* Select a power cylinder of a sufficient thrust, allowing for a safety factor so that the loads used (static and dynamic) do not exceed the rated thrust.

## Characteristics graph

### 12V DC power source

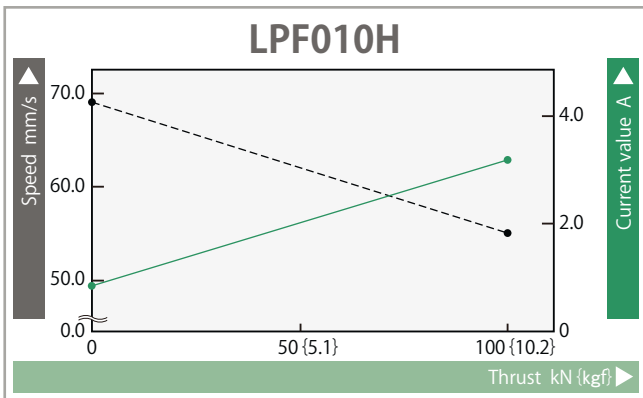

### 24V DC power source

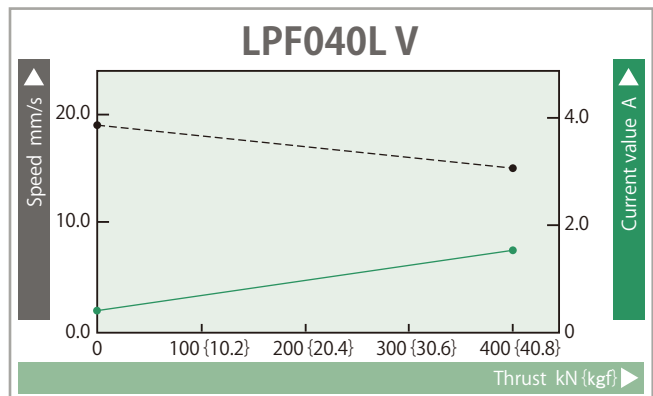
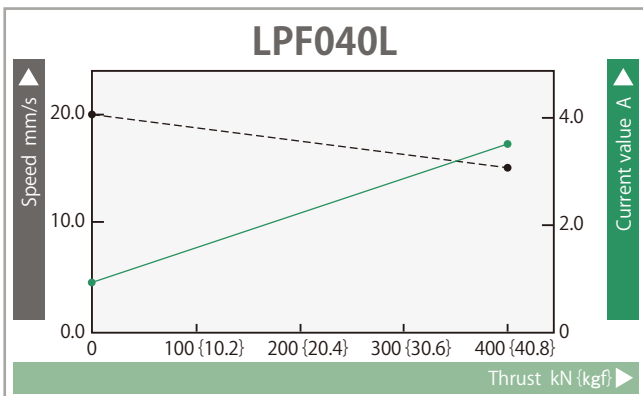
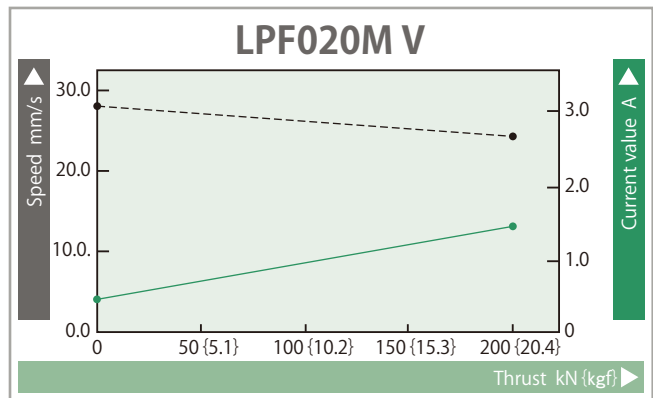
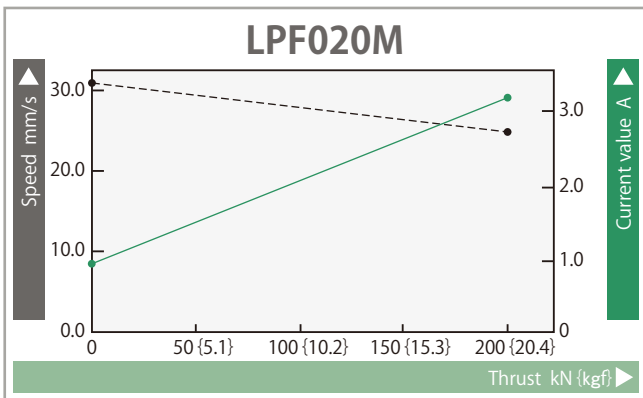
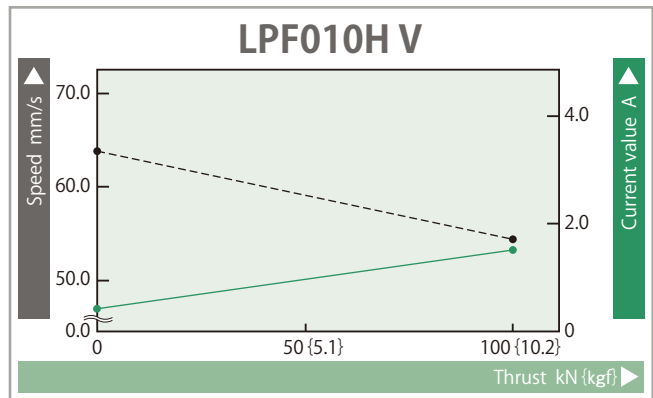

(Note) The graphs show standard values (12V/24V DC power source, ambient temperature 20°C). The speed and the current value vary depending on conditions of power source and ambient temperatures, etc.



12V DC power source

24V DC power source

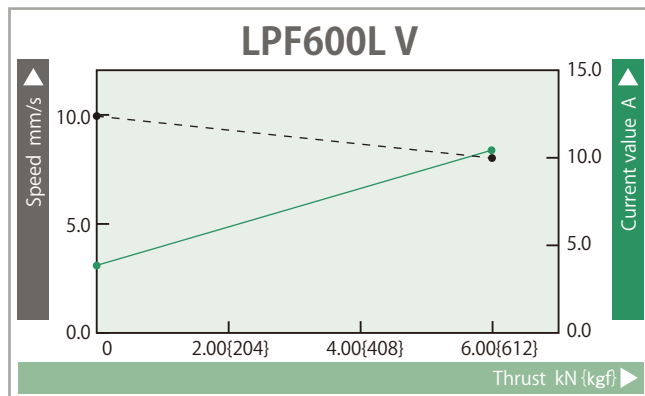
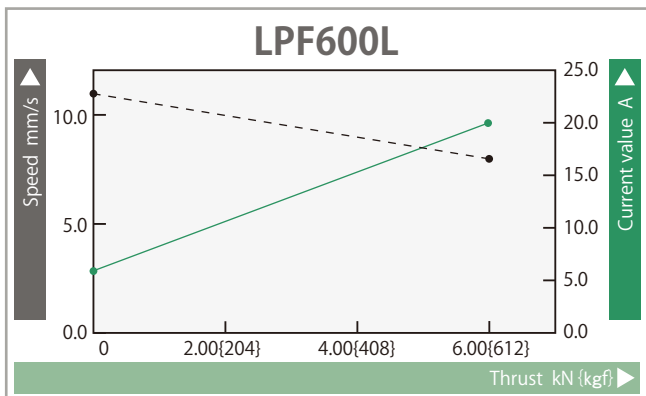
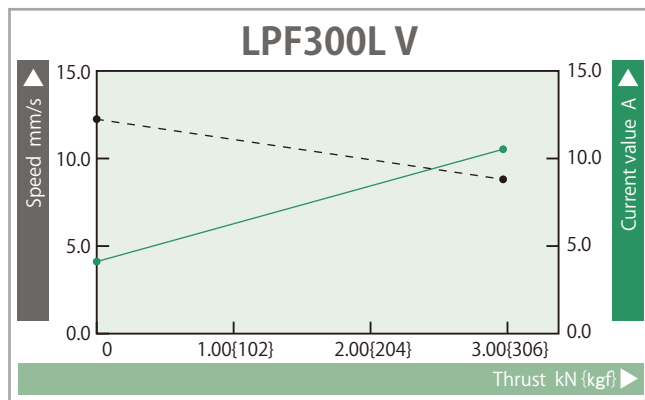
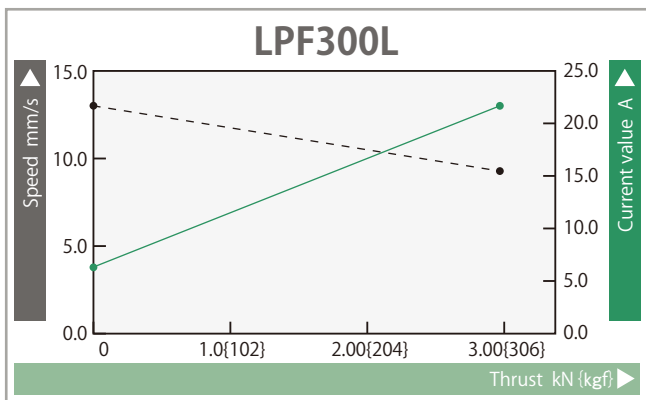
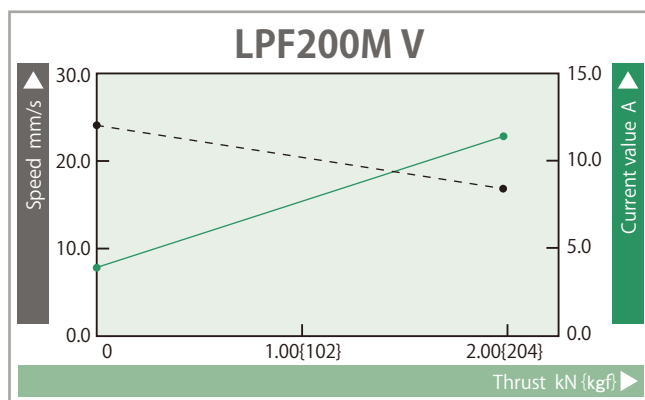
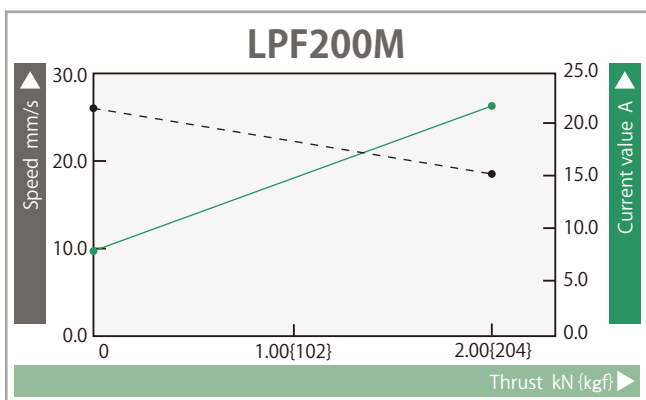
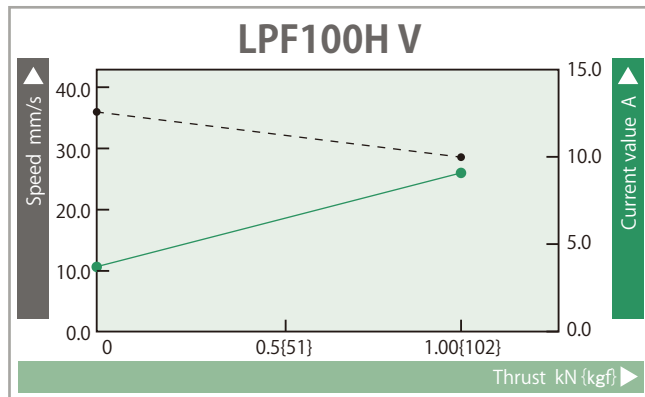
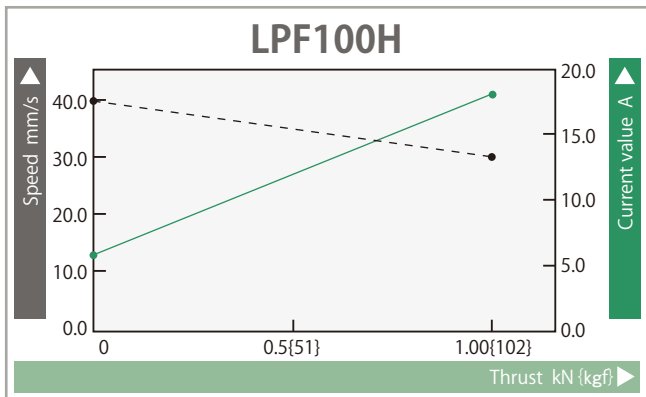

(Note) The graphs show standard values (12V/24V DC power source, ambient temperature 20°C). The speed and the current value vary depending on conditions of power source and ambient temperatures, etc.

## Dimensions Table

### LPF010~LPF040: Basic type

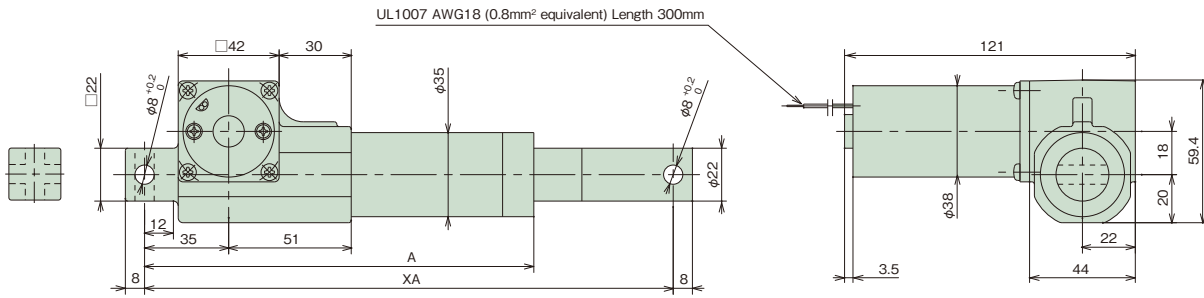

Model number		Rated thrust		Stroke	Rated speed	Dimensions mm			Approximate mass
						A	XA		
N	{kgf}	mm	mm/s	MIN.	MAX.		kg		
LPF010H	0.5 V	100	10.2	50	54	162	220	270	1.0
	1.0 V			100		212	270	370	1.2
	1.5 V			150		262	320	470	1.4
	2.0 V			200		312	370	570	1.6
	3.0 V			300		412	480	780	2.0
LPF020M	0.5 V	200	20.4	50	24	162	220	270	1.0
	1.0 V			100		212	270	370	1.2
	1.5 V			150		262	320	470	1.4
	2.0 V			200		312	370	570	1.6
	3.0 V			300		412	480	780	2.0
LPF040L	0.5 V	400	40.8	50	15	162	220	270	1.0
	1.0 V			100		212	270	370	1.2
	1.5 V			150		262	320	470	1.4
	2.0 V			200		312	370	570	1.6
	3.0 V			300		412	480	780	2.0

Note) V is attached at the end of the model number for 24V DC.

## Options

### ■ With external limit switch for stroke adjustment

Note) No limit switch for stroke adjustment is attached to the model of 50 mm stroke.

The above-mentioned XA dimensions will not change even after attaching an external limit switch for stroke adjustment and bellows. The mechanical stroke preset value is 60mm or more. However, note that it does not include the coasting distance.

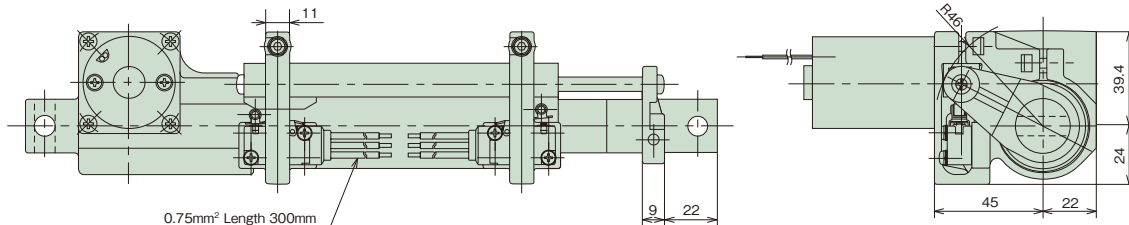

### ■ With bellows

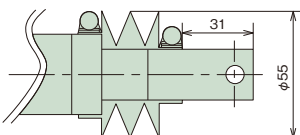

### ■ LS specification (common for LPF010H – LPF600L)

Model	D2VW-5L2A-1M equivalent OMRON
Circuit configuration	
Power rating	250V AC 4A (cos $\phi=0.7$ ), 30V DC 4A (time constant 7ms or less)
Connection	0.75mm <sup>2</sup> × 3C Length 300m, discrete lead wire

## Dimensions Table

### LPF100~LPF600: Basic type

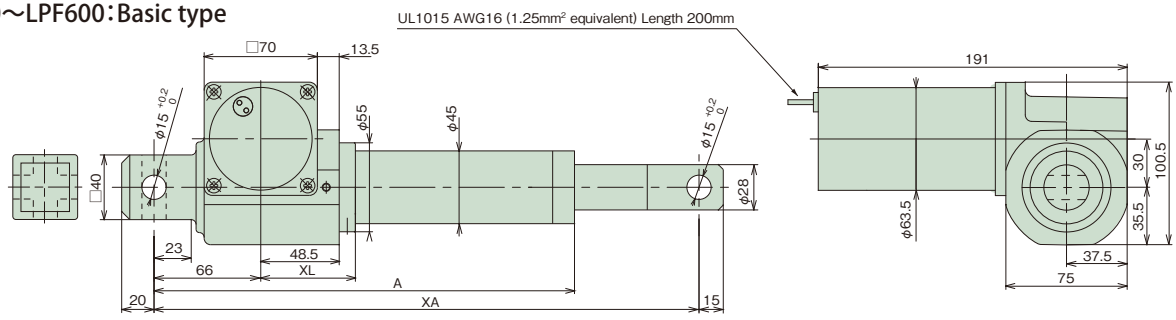

Model number		Rated thrust		Stroke	Rated speed	Dimensions mm			Approximate mass	
						XL	A	XA		
		kN	{kgf}	mm	mm/s		MIN.	MAX.	kg	
LPF100H	0.5 V	1.00	102	50	30	58.5	210	275	325	5.0
	1.0 V			260			325	425	5.3	
	1.5 V			310			395	545	5.6	
	2.0 V			360			445	645	5.9	
	3.0 V			460			545	845	6.5	
LPF200M	0.5 V	2.00	204	50	18	58.5	210	275	325	5.0
	1.0 V			260			325	425	5.3	
	1.5 V			310			395	545	5.6	
	2.0 V			360			445	645	5.9	
	3.0 V			460			545	845	6.5	
LPF300L	0.5 V	3.00	306	50	9	58.5	210	275	325	5.0
	1.0 V			260			325	425	5.3	
	1.5 V			310			395	545	5.6	
	2.0 V			360			445	645	5.9	
	3.0 V			460			545	845	6.5	
LPF600L	1.0 V	6.00	612	100	8	95.5	297	360	460	5.9
	2.0 V			397			480	680	6.5	
	3.0 V			497			580	880	7.1	
	4.0 V			597			705	1105	7.8	
	5.0 V			697			805	1305	8.4	
	6.0 V			797			920	1520	9.0	

Note) V is attached at the end of the model number for 24V DC.

## Options

### ■ With external limit switch for stroke adjustment

Note) No limit switch for stroke adjustment is attached to the model of 50 mm stroke.  
 The above-mentioned XA dimensions will not change even after attaching an external limit switch for stroke adjustment and bellows.  
 The mechanical stroke preset value is 60mm or more. However, note that it does not include the coasting distance.

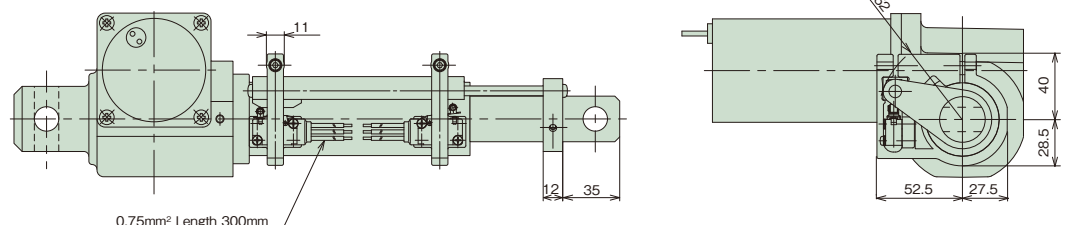

### ■ With bellows

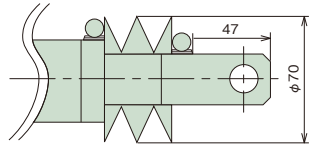

## Position Detection unit

### ① LPF010~LPF040

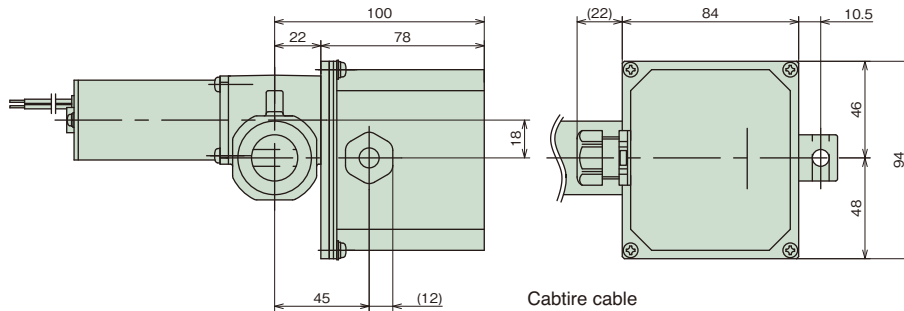

Cable cable  
 0.5mm<sup>2</sup> x 6C length 500mm (internal limit switch)  
 0.5mm<sup>2</sup> x 3C length 500mm (potentiometer)

For connection, see the position detecting device specifications on page 60.

### ② LPF100~LPF300

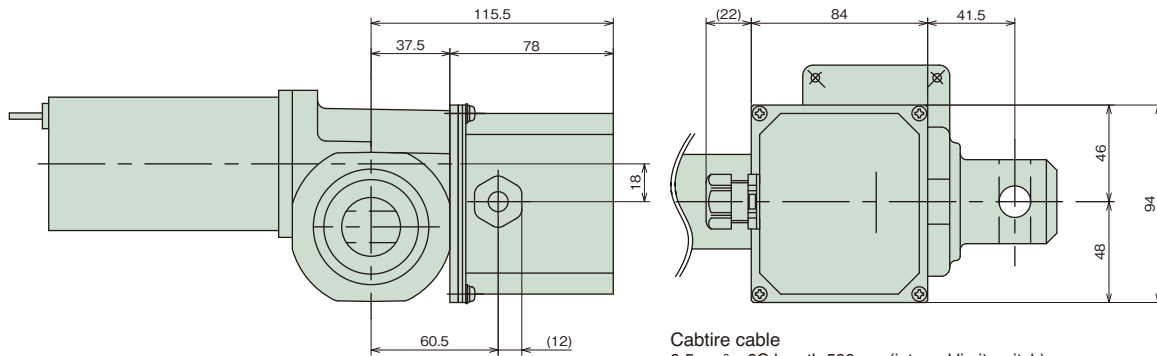

Cable cable  
 0.5mm<sup>2</sup> x 6C length 500mm (internal limit switch)  
 0.5mm<sup>2</sup> x 3C length 500mm (potentiometer)

For connection, see the position detecting device specifications on page 60.

Note) Note that a position detecting unit cannot be manufactured for LPF600.

## Internal structure

For the position detecting unit, the following 2 types of position detecting devices can be built in as requested.

### ① Internal limit switch for position detection

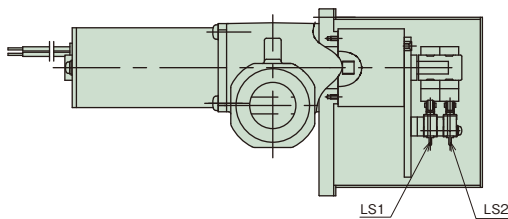

### ② Potentiometer

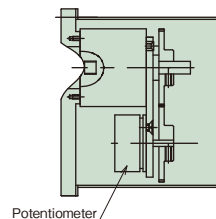

Note) An internal limit switch for position detection and a potentiometer cannot be used together.



## Position detecting device specifications

### Internal limit switch for position detection

Use this LS when an external limit switch cannot be attached for reasons of installation space, or when the atmosphere is an adverse environment (with litter, dust, corrosion, etc.). When attaching 2 positions: Option code K2

Note) Up to 2 internal limit switches can be built in. (A position detecting device with 4 internal LS cannot be manufactured)

#### Setting of limit switch

1. Operate the power cylinder individually before installing to the machine and check the rotation direction of the LS cam.
2. Install the power cylinder to the machine, and move the rod to a desired position to stop or to a position to detect the position.
3. Rotate the LS cam and tighten the hexagon socket set screw and fix it at the position where the microswitch acts. At this point, based on the previously checked rotating direction, set the LS at the front side considering the cylinder coasting amount.

Model	SS-5GL2 equivalent OMRON
Circuit configuration	LS 1 for extend (Black, White, Red) / LS 2 for retract (Green, Yellow, Brown)
Electrical rating	250V AC 2A (cos φ = 0.4)
Connection	0.5mm <sup>2</sup> × 6C Length 500 mm Cabtire cable

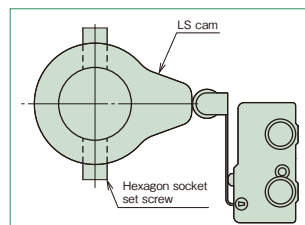

### Potentiometer

This is a variable resistor to output electrical signals according to the stroke amount of the cylinder.

Use it together with a print board and a stroke indication meter.

The resistance value according to the model is already adjusted at the time of shipment.

The potentiometer is set to work within the effective angle.

Note that if the rod is rotated before installation, a phase with stroke will shift.

Model	CP-30 equivalent Sakae Tsushin Kogyo
Total resistance	1kΩ
Power rating	0.75W
Dielectric strength	1000V AC 1min.
Effective electrical angle	355° ± 5°
Effective mechanical angle	360° Endless
Connection	0.5mm <sup>2</sup> × 3C Length 500 mm Cabtire cable

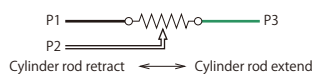

#### <Cautions>

- \* Note that LPF600 type with a position detecting unit is not available.
- \* When an internal limit switch for position detection and a potentiometer are attached, the torque limiter mechanism is removed to prevent deviation in the preset values. Do not apply any load of the rated thrust or more to the cylinder during installation and operation of the cylinder. It may cause burnout of the motor. And do not hit the cylinder on the stroke end. It may cause the rod to get caught or burnout the motor.

## Control optional

**Overload detection unit** Necessary for protection against instantaneous overload and for press contact stop.

Applicable for LPF010, LPF020, LPF040 \* For LPF100 through 600, the overload detection unit is a special type.

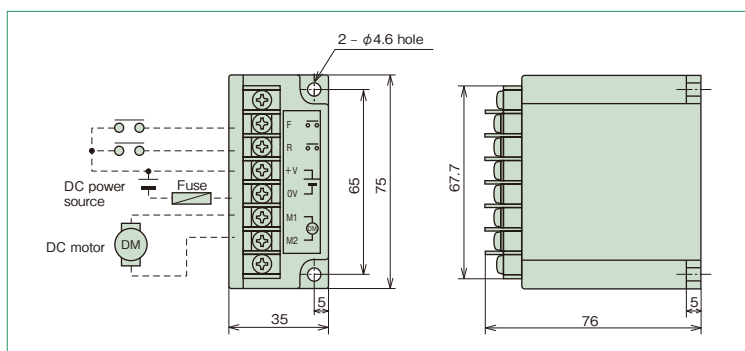

Model number	LPF-K12	LPF-K24
Power source	10 ~ 14V DC	20 ~ 28V DC
Rated current	3.7A DC	1.8A DC
Overload protection function	Load current	7.0A DC (fixed) / 4.0A DC (fixed)
	Start time	0.3s (fixed)
	Shock time	0.1s or less (fixed)
Operation specifications	Rod extend at ON between F and +V Rod retract at ON between R and +V Rod stops with ON both between F and +V and between R and +V	
Ambient temperature	-15 ~ 40°C	
Ambient humidity	45 ~ 85%RH (no dew condensation)	
Structure	Panel inside storing type Case: ABS	
Mass	0.2kg	

\* No signal is output at time of overload.

### AC adapter

Applicable for LPF010, LPF020, LPF040 \* AC adaptor for LPF100 to 600 is not available.  
\* As for LPF100 to 600, a special type with an AC motor is manufactured.

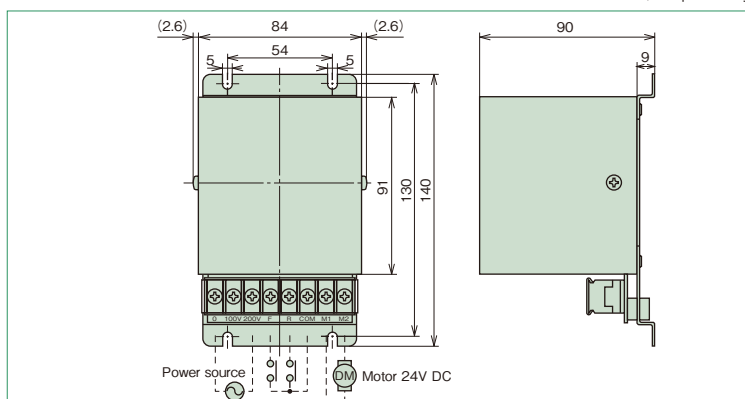

Model number	LPF-A24	
Applicable motor	24V DC 29W	
Power source	Commercial power source 100V AC 50/60Hz / 200/220V AC 50/60Hz	
Rated current	1.8A DC	
Overload protection function	Load current	4.0A DC (fixed)
	Start time	0.3s (fixed)
	Shock time	0.1s or less (fixed)
Operation specifications	Rod extend at ON between F and COM Rod retract at ON between R and COM Rod stops with ON both between F and COM and between R and COM	
Ambient temperature	-15 ~ 40°C	
Ambient humidity	45 ~ 85%RH (no dew condensation)	
Structure	Panel inside storing type Case: SPCC	
Mass	2.5kg	

Note) Check the cautions on page 62 when using an AC adapter.

\* The overload protection function is built in the AC adapter.

## Control option (for potentiometer)

### Stroke indication meter



Stroke is indicated by % according to the signal from the print board.

Model number	RM80B (100 $\mu$ A DC) equivalent
Class	JIS C 1102 2.5 class
Appearance	Frame · Black
Scale specifications	Full stroke indicated by 100%

**Print board** Model number | **LPCO-D1** (Operation power: 100/110V 50/60Hz)  
| **LPCO-D2** (Operation power: 200/220V 50/60Hz)

The voltage signal from the potentiometer of the position detecting unit of the Power Cylinder F series is converted to a current value.

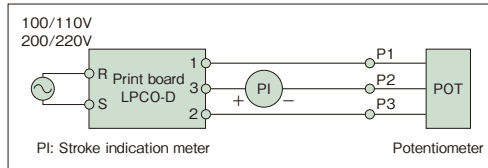
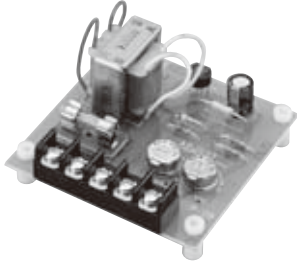

Adjust the meter with the adjustment dial on the print board. Do not make a mistake with the stroke indication meter (+) and (-). Replace the terminals 1 and 2 on the print board to make the indication meter 100% when the stroke is minimum.

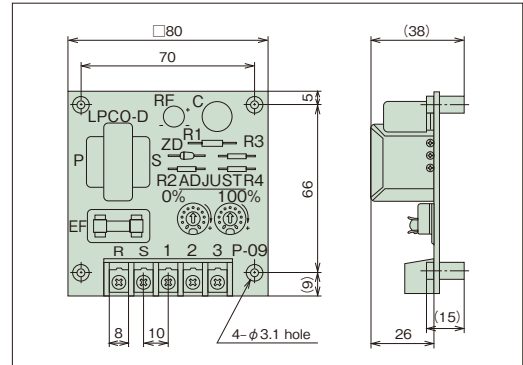
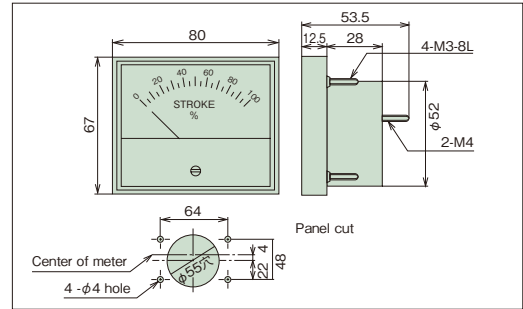

### Meter relay (the print board is the same as the print board of the stroke indication meter.)



Used for simple adjustment of stroke on the operation panel.

( Iron panel is standard.  
Contact TEM when installing an aluminum panel.)

Model number	NRC-100HL (TSURUGA) equivalent
Class	JIS C 1102 2.5 class
Appearance	Frame: Black
Scale	Full stroke indicated by 100%
Power source	100/100V AC, 200/220V AC 50/60Hz
Input	100 $\mu$ A DC maximum
Output contact structure	1C for both HIGH, LOW sides (Refer to the figure at the right)
Contact capacity	250V AC 3A (cos $\phi$ = 1)

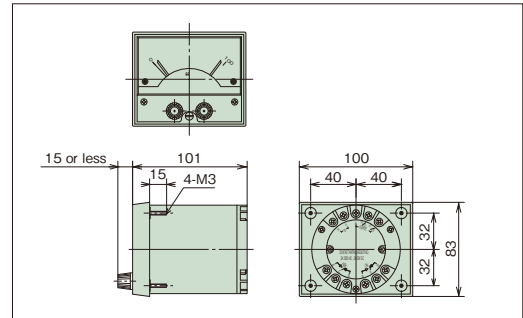

#### <Relay operation>

(In the case of b contact)

Wiring is the same as the stroke indication meter, however, power supply is separately required for the meter relay. Supply from the operation power source, etc. As for the output contact, it is easy to connect the b contact serially to the b contact of the stroke adjustment LS, etc.

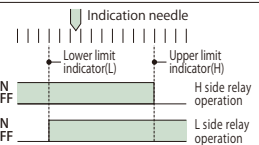

Wire connection diagram

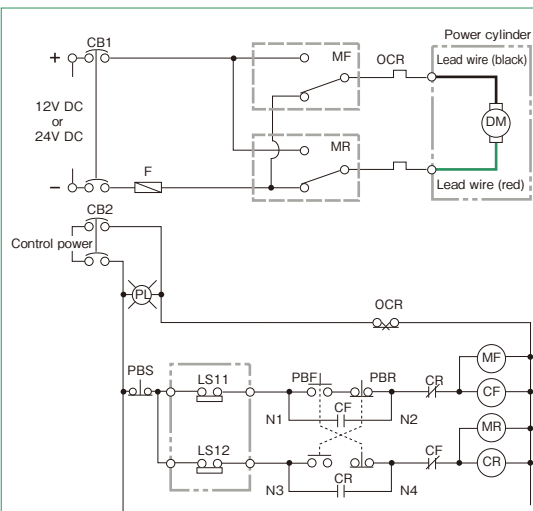

LS11: Extend stroke adjustment external LS  
 LS12: Retract stroke adjustment external LS

- NOTE :**
- (1) This diagram shows a single-acting circuit. When using in an inching circuit, remove the wire connections between N1 and N2, N3 and N4, and short-circuit the PBS.
  - (2) A [ ] portion indicate a supply range of the power cylinder. Provide others than the [ ] portion on your side. (Stroke adjustment external LS is our option.)
  - (3) Recommended breakers for LPF100H through LPF600L  
 For 12V DC: NF32-SW 30A 250V DC (Mitsubishi Electric) or equivalent  
 For 24V DC: NF32-SW 15A 250V DC (Mitsubishi Electric) or equivalent
  - (4) Thermal relays for LPF100H through LPF600L  
 For 12V DC: TH-N20 (Mitsubishi Electric) or equivalent  
 For 24V DC: TH-N12 (Mitsubishi Electric) or equivalent

Use drive relays (MF, MR) with the following capacities.

Model	12V DC Spec.	24V DC Spec.
LPF010H LPF020M LPF040L	30A or more (14V DC)	30A or more (28V DC)
LPF100H LPF200M LPF300L LPF600L	70A or more (12V DC)	60A or more (24V DC)

\* Drive relays for LPF100H through 600L are also available from us. Contact us.

Use fuses with the following capacities as a guide.

Model	12V DC Spec.	24V DC Spec.
LPF010H LPF020M LPF040L	10A	5A
LPF100H LPF200M LPF300L LPF600L	20A	10A

**\* CAUTION**

Be careful of the wire length (between motor and DC power source) and wire diameter in order to prevent voltage drop. Voltage drop may reduce the predetermined performance.

Overload detection unit (used for LPF010 through LPF040)

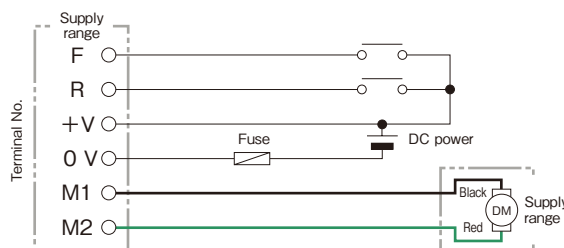

**\* CAUTION**

When the overload detection has tripped, it is necessary to turn OFF the operation signal F or R once. If it is not turned OFF (not reset), a state that voltage is not output to the motor will be held. (Common to AC adaptor)  
 (In the case of jogging operation, it is reset as the contact is opened when the push button is released (F or R is turned OFF).)

AC adaptor wire connection diagram (used for LPF010 through LPF040)

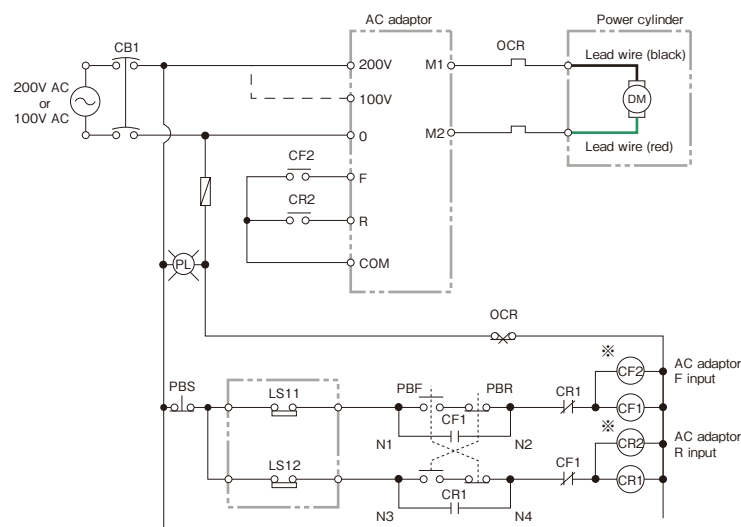

LS11: Extend stroke adjustment external LS  
 LS12: Retract stroke adjustment external LS

**NOTE :**

- (1) This diagram shows a single-acting circuit. When using in an inching circuit, remove wire connections between N1, N2, N3 and N4.
- (2) A [ ] portion indicate a supply range of the power cylinder and AC adaptor. Provide others than the [ ] portion on your side. (Stroke adjustment external LS is our option.)
- (3) For relays of CF1, CF2 and CR2, OMRON relay MY or equivalent is recommended.
- (4) If the power source is 100V AC, connect the power to the dotted line part (100V terminal).

**\* CAUTION**

1. Securely separate contacts of the relays CF2, CR2 connected to the operation signals F, R on the AC adaptor from the AC circuit (200V class, 400V class) for use. If the AC circuit is built in the same relay, arc is generated between contacts due to surge, and the AC adaptor may be broken.
2. If a surge intrudes from the power line, connect a surge killer to the power terminal as a surge countermeasure. Surge killers which we recommend are 100V terminal - ENC221D\*, 200V terminal - ENC471D\*(Fuji Electric). For details on surge countermeasures, contact TEM.

# WARNING

## ■ Cautions for installation

- Use pins to connect the power cylinder with the equipment. Align phases of pins (clevis fitting pin and end fitting pin).
- Apply grease into the clevis fitting holes and end fitting holes, and pins before installation.
- Pay attention so as not to apply a lateral load on the power cylinder when installing.
- All models are totally enclosed structures so that they can be used normally outdoors, however, under adverse conditions exposed to constant water and steam etc., and snow accumulation, although they are an outdoors type, an appropriate cover is required. The power cylinder can generally be used in a range of -5°C to 40°C, although it varies depending on the use conditions. When using at 40°C or higher, always protect with a heat insulating cover, etc. Never use in a flammable atmosphere, otherwise it may cause an explosion and fire. In addition, avoid using it in a location where vibration or shock exceeding 1G is applied.
- The main body is of outdoor specifications however, carry out proper waterproofing treatment on the motor lead wire terminal with waterproofing connectors etc.

## ■ Cautions for use

- Speed and current value change with an increase/decrease in load. For details, refer to the characteristics diagram. Linkage operation cannot be performed due to characteristics of the motor.
- When rectifying alternating current to use without using battery power, make sure to smoothen the current and provide a DC power supply with a capacity so that the voltage does not drop. It greatly affects performance of the power cylinder and the duration of the life of the brush. (As an option, an AC adaptor for an output voltage of 24V is available. This adaptor supports LPF010 to 040 only. For LPF 100 or larger, contact us separately. When using with other than commercial power supply, check that power voltage variation is within a range of  $\pm 10\%$  and the power supply is an alternating current power supply without strain.)
- When using an AC adaptor, use a power cylinder of 24V DC specifications.
- 12V DC specifications are within a voltage range from 10 to 14V, and 24V DC specifications are within a voltage range from 20 to 28V. Note that the speed varies if the voltage varies due to the characteristics of the DC motor.
- No overload detection mechanism is built in the LPF series. When detecting an overload, commonly use the overload detection unit as an option. For LPF010 to 040, combine with the overload detection unit to allow for press stopping. (For LPF100 to 600, an overload detection unit of special model can be manufactured, however, press stopping cannot be performed.)  
When press stopping is performed, allow the equipment to have a sufficient strength (rated thrust x 300%)  
When not using the overload detection unit, never perform press stopping, and use within the stroke range otherwise the power cylinder may be damaged.
- A model of stroke 50mm cannot be equipped with a stroke adjustment external LS. The mechanical stroke adjusting range of the stroke adjustment external LS is 60mm or more. However, note that it does not include a coasting distance.
- If coasting becomes a problem, provide a dynamic brake circuit separately.
- Our overload detection unit and AC adapter are provided with a dynamic brake circuit.
- Anti-rotation is required because the rod of the power cylinder generates a rotating force with thrust. The rotating force of the rod is as follows.

Model		LPF010H	LPF020M	LPF040L	LPF100H	LPF200M	LPF300L	LPF600L
Rod rotating force	N·m	0.14	0.28	0.55	1.75	3.50	5.25	5.81
	{kgf·m}	0.014	0.029	0.056	0.179	0.357	0.536	0.593

## ■ Cautions for maintenance and inspection

- The operating portion and reduction portion are filled with grease, therefore, it is not necessary for them to be greased.
- The duration of life is 15000 reciprocations as a guide.
- Structurally, repairs and parts supply are not available.  
If the above reference life is exceeded, replace the main body with a new one.

# F series plus $\alpha$

Plus  $\alpha$  Ver.1 with AC motor

**Model designation** **LPF 100 H 1.0 X - TK**

LPF series    Thrust    Speed    Stroke    With special motor    Special model

\* Specify single-phase or three-phase power voltage.  
(Power cylinder with brake is also available.)

Optimum for food machines,  
air conditioning equipment and  
incineration equipment!

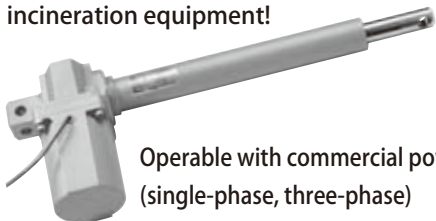

Operable with commercial power  
(single-phase, three-phase)

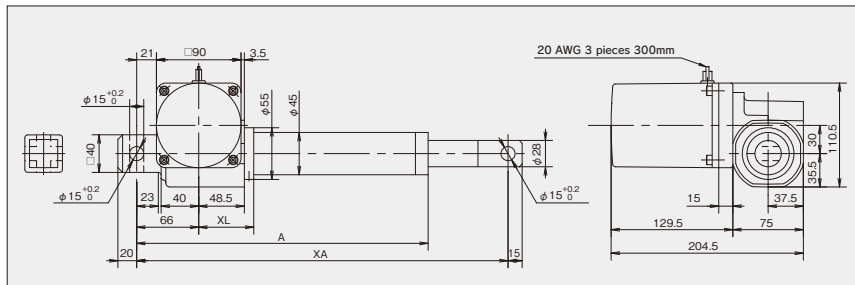

### Dimensions Table

Model	Stroke mm	Dimensions mm			
		XL	A	XA	
			MIN	MAX	
LPF100H LPF200M LPF300L	50	58.5	210	275	325
	100		260	325	425
	150		310	395	545
	200		360	445	645
LPF600L	300	95.5	460	545	845
	400		297	360	460
	500		397	480	680
	600		497	580	880
			597	705	1105
			697	805	1305

### Motor specification

	Single-phase		Three-phase
	Capacitor run	Capacitor run	Induction motor
Output	90W	90W	90W
Number of poles	Four-pole	Four-pole	Four-pole
Power	Voltage	200/200V	200/200/220V
	Frequency	50/60Hz	50/60/60Hz
Heat resistance class	E	E	E
Capacitor capacity	30 $\mu$ F (Attached)	7.5 $\mu$ F (Attached)	
Time rating	S2 15min	S2 15min	S2 15min
Protection class	(Indoor type) IP42	(Indoor type) IP42	(Indoor type) IP42

### Standard use environment

Environment	Model	Indoor type
	Ambient temperature	
Relative humidity		85% or less
Impact resistance value		1G or less
Installation altitude		1000m or lower above sea level
Atmosphere		<ul style="list-style-type: none"> <li>Indoor location which is not directly exposed to rain, wind, lightning or sunlight.</li> <li>Extent of sand and dust which exist in general factory (5mg/m<sup>3</sup> or less)</li> </ul>

### Nominal speed list

Type	Single-phase		Three-phase
	100/100v 50/60Hz	200/200v 50/60Hz	200/200/220v 50/60/60Hz
LPF100H	9.0 / 11		9.0 / 11 / 11
LPF200M	6.0 / 7.0		6.0 / 7.0 / 8.0
LPF300L	3.0 / 4.0		3.0 / 4.0 / 4.0
LPF600L	2.5 / 3.0		2.5 / 3.0 / 3.0

- 1) Characteristic current value and speed of the cylinder may change due to influence of grease when it is used at low temperatures.
- 2) Cylinders with bellows are recommended in an excessively dusty location.

Plus  $\alpha$  Ver.2 with ball clutch type overload protection device

**Model designation** **LPF 100 H 1.0 - TK**

LPF series    Thrust    Speed    Stroke    Special model

\* Designate as "with ball clutch type overload protection device."

Optimum for agricultural machines!



Clicking sound informs  
of overload!

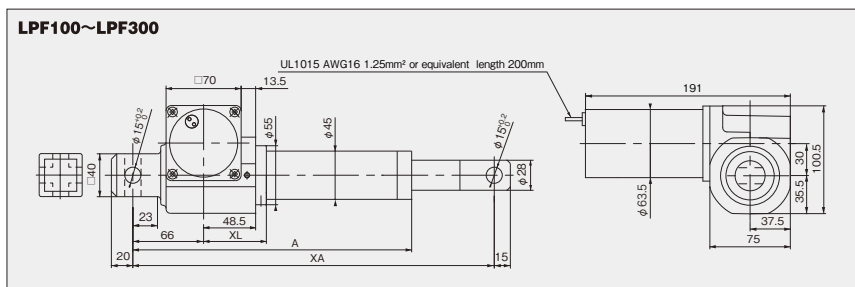

### Dimensions Table

Model	Rated thrust kN / (kgf)	Stroke mm	Rated speed mm/s	Dimensions (mm)			Approx. Mass kg			
				XL	A	XA				
LPF100H	1.00	0.5 V	102	30	58.5	50	210	275	325	5.0
		1.0 V				100	260	325	425	5.3
		1.5 V				150	310	395	545	5.6
		2.0 V				200	360	445	645	5.9
		3.0 V				300	460	545	845	6.5
LPF200M	2.00	0.5 V	204	18	58.5	50	210	275	325	5.0
		1.0 V				100	260	325	425	5.3
		1.5 V				150	310	395	545	5.6
		2.0 V				200	360	445	645	5.9
		3.0 V				300	460	545	845	6.5
LPF300L	3.00	0.5 V	306	9	58.5	50	210	275	325	5.0
		1.0 V				100	260	325	425	5.3
		1.5 V				150	310	395	545	5.6
		2.0 V				200	360	445	645	5.9
		3.0 V				300	460	545	845	6.5

### Motor specifications

Model	Item	Voltage V	Output W	Rated time
LPF100H		12	160	5 minutes
LPF100H V		24		
LPF200M		12		
LPF200M V		24		
LPF300L		12		
LPF300L V		24		

### Standard use environment

Environment	Model	Outdoor type
	Ambient temperature	
Relative humidity		85% or less
Impact resistance value		1G or less
Installation altitude		1000m or lower above sea level
Atmosphere		Normal outdoors

- 1) If used below the freezing point, the characteristics of the cylinder (current value, speed) may change from the influence of grease.
- 2) Cylinders with bellows are recommended in an excessively dusty location.
- 3) All models are totally enclosed structures so that they can be used normally outdoors, however, when exposed to constant adverse conditions such as water, steam and snow accumulation, an appropriate cover is required. When using at 40°C or higher, always protect with a heat insulating cover, etc. Never use in a flammable atmosphere, otherwise it may cause an explosion and fire. In addition, avoid using it in a location where vibration or shock exceeding 1G is applied.



# F series Plus $\alpha$

Plus  $\alpha$  Ver.3A Parallel (folded type)

## Model designation

**LPF 100 M K 1.0 - TK**

LPF series    Thrust    Speed    Parallel    Stroke    Special model

Optimum for outdoor use such as agricultural machines!

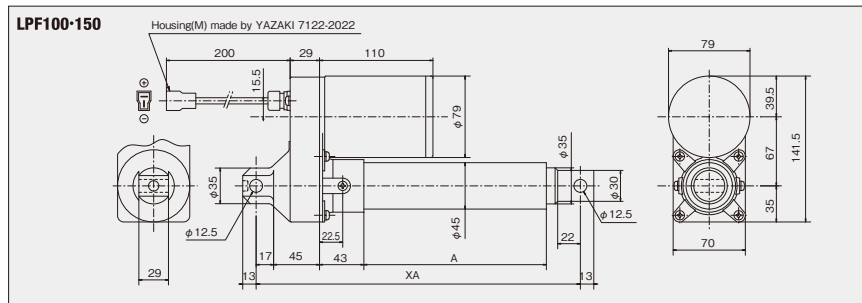
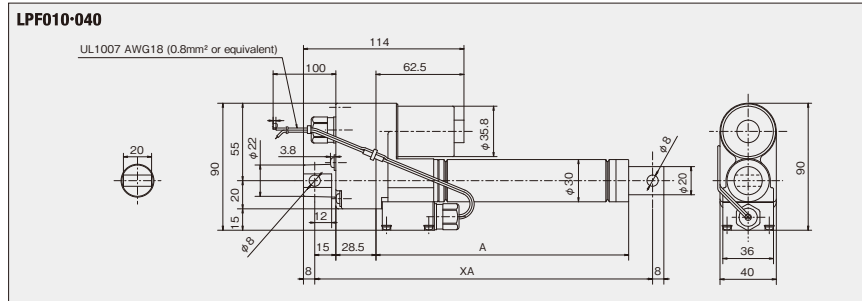
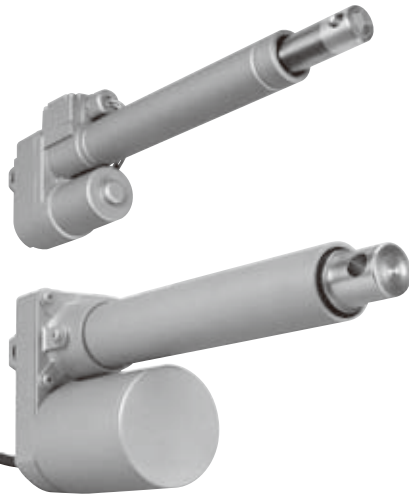

\*Provide a YAZAKI housing (F) 7123-2024 (1 piece), terminal (F) 7116-2090 (2 pieces) for counterpart of the connector. Waterproof connectors are also available.

### ■ Dimensions Table

#### LPF010-040

Model	Stroke mm	Dimension mm			Approx. mass kg
		A	XA		
LPF010MK 0.5(V)	50	129.5	MIN	190	0.8
LPF040LK 0.5(V)			MAX	240	
LPF010MK 1.0(V)	100	179.5	MIN	240	0.9
LPF040LK 1.0(V)			MAX	340	
LPF010MK 1.5(V)	150	229.5	MIN	290	1.0
LPF040LK 1.5(V)			MAX	440	
LPF010MK 2.0(V)	200	279.5	MIN	340	1.1
LPF040LK 2.0(V)			MAX	540	

#### LPF100-150

Model	Stroke mm	Dimension mm			Approx. mass kg
		A	XA		
LPF100MK 0.5(V)	50	77	MIN	205	3.6
LPF150LK 0.5(V)			MAX	255	
LPF100MK 1.0(V)	100	127	MIN	255	3.9
LPF150LK 1.0(V)			MAX	355	
LPF100MK 1.5(V)	150	177	MIN	305	4.2
LPF150LK 1.5(V)			MAX	455	
LPF100MK 2.0(V)	200	227	MIN	355	4.5
LPF150LK 2.0(V)			MAX	555	

### ■ Standard model

Model	Rated thrust		Thrust detecting load		Stroke mm	Rated speed mm/s	Power V	Rated load current A	Locked rotor current A
	N	{kgf}	N	{kgf}					
LPF010MK	100	10.2	157	16	50	50	12V DC (24V DC)	3.4 (1.7)	9.0 (4.2)
					100				
					150				
					200				
LPF040LK	400	40.8	490	50	50	15	12V DC (24V DC)	3.0 (1.5)	9.0 (4.2)
					100				
					150				
					200				
LPF100MK	1.0ok	102	Without thrust detecting mechanism * A ball clutch is built in for overload protection. However, it cannot be used for press stopping.		50	27	12V DC (24V DC)	13 (6.5)	58 (34)
					100				
					150				
					200				
LPF150LK	1.5ok	153			50	17	12V DC (24V DC)	13 (6.5)	58 (34)
					100				
					150				
					200				

### ■ Standard use environment

Model	Outdoor type	
Environment	Ambient temperature	-5 ~ 40°C
	Relative humidity	85% or less
	Impact resistance value	1G or less
	Installation altitude	1000m or lower above sea level
	Atmosphere	Normal outdoors

## Precautions for use

### 1. About voltage

The voltage shall be 12V DC  $\pm$ 10% or 24V DC  $\pm$ 10%. If the voltage is low, the cylinder will slow down, due to which the overload detection LS may not operate.

Be aware that if the voltage is high, it may be caught at the stroke end.

(LPF100 and LPF150 should also be used within the above voltage range).

### 2. Pressing force

In the case of press contact stopping, maximum pressing forces of 245N {25kgf} and 784N {80kgf} are exerted on LPF010MK and LPF040LK, respectively. Be aware that LPF100 and LPF150 cannot be used for press contact stopping.

### 3. Outdoor use

All models have a totally enclosed structure so that they can be used normally outdoors. Even so, however, an appropriate cover is required in a severe environment that is splashed with water or vapor or in such a location where snow accumulates.

For lead wire connection, use a waterproof connector.

### 4. Other

With use below freezing, the characteristics (current value and speed) of the cylinder may vary according to the effect of grease.

For use at 40° C or higher, always protect with a heat-insulating cover, etc.

Never use in a flammable atmosphere. Doing so may cause an explosion or fire.

In addition, avoid using in a location subjected to vibration or impact exceeding 1G.

## Power Cylinder

# G series

### Thrust : 700N to 3.00kN {71.4kgf to 306kgf}

Power cylinder in intermediate thrust zone which can be used with AC power supply.

This can be used across a wide range of applications such as steel, food and multistory car parking for general industry.

#### ● Wide variation

Basic 630 models and approximately 9000 models including option are standardized.

LPGA: Simple and basic economical type

LPGB: Built-in slip overload protection mechanism type

LPGC: Built-in thrust detection, press stop mechanism type

#### ● Screw type selectable according to use

Trapezoidal screw excellent in cost performance

Best-suited for low-speed, low-frequency use

High-efficiency, long-life ball screw

Best-suited for high-speed, high-frequency use

#### ● Quick delivery of special motor (For details, refer to page 120.)

Heat resistance class F and class H are supported.

Different voltage specifications (Overseas voltages are supported.)

Inverter specifications

Global specifications (CE-compliant, UL-compliant and CCC-compliant)

Explosion-proof specifications

#### ● Quiet operation

Noise at the start and stop has been greatly reduced by drive of the motor with a quiet DC brake.

#### ● Excellent speed stability

This power cylinder is basically structured so that the screw shaft is rotated by the induction motor and the nut (rod) is extend and retract, allowing for a stable speed run which is hardly affected by load variation.



## Model No. designation

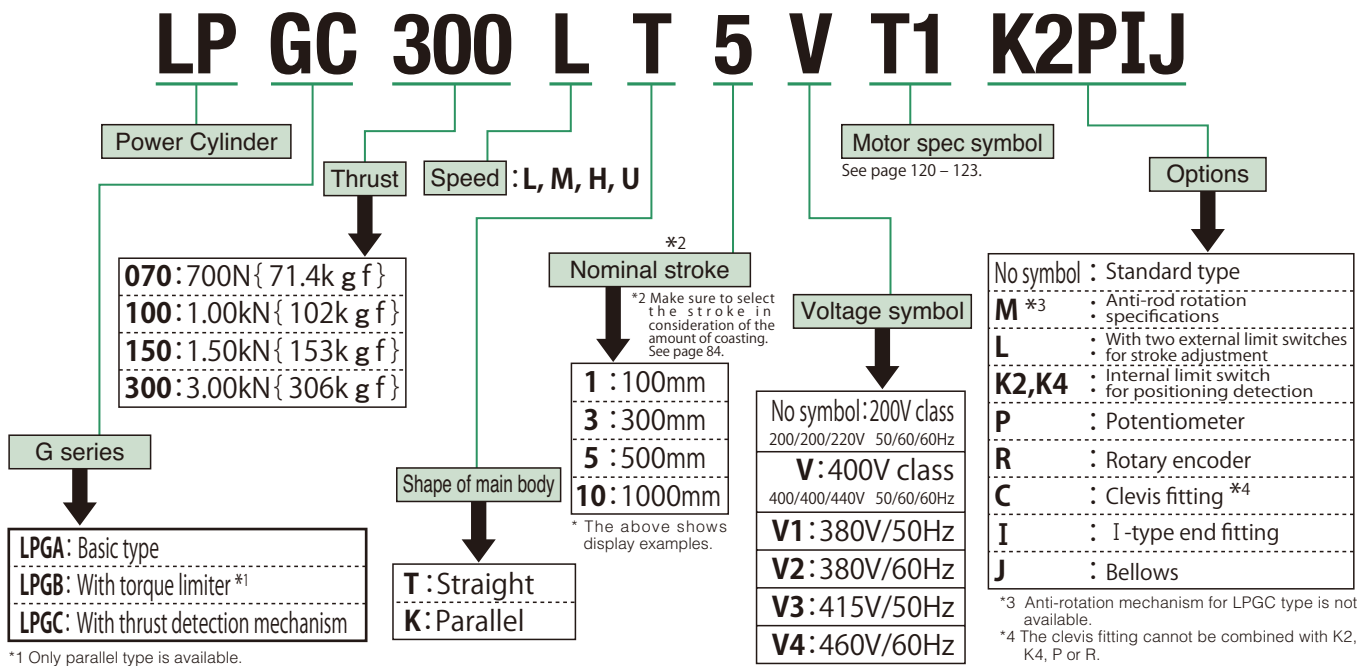

## Trapezoidal screw type standard model list

Model	Speed symbol	Rated thrust N { kgf }	Nominal speed mm/s 50/60Hz	Motor capacity kW	Rod movement per turn of manual shaft mm	Rod rotating force		Nominal stroke mm	Main body shape		Type		Option						
						N·m	{ kgf·m }		Straight	Parallel	Basic	With torque limiter	With thrust detection mechanism	Bellows	External LS	Position detection unit	I-type end fitting	Clevis fitting	Anti-rotation mechanism
LPGA070	L	700 { 71.4 }	25/30	0.1	1	1.54	0.16	100				*1				*1	*1	*2	
LPGB070	M		75/90	0.2	3	2.31	0.24												
LPGC070	H		100/120	0.4	4	1.54	0.16												
LPGA100	L	1.00k { 102 }	25/30	0.1	1	2.20	0.22	300				*1				*1	*1	*2	
LPGB100	M		75/90	0.2	3	3.29	0.34												
LPGC100	H		100/120	0.4	4	2.20	0.22												
LPGA150	L	1.50k { 153 }	25/30	0.2	1	3.29	0.34	500				*1				*1	*1	*2	
LPGB150	M		75/90	0.4	3	4.94	0.50												
LPGC150	H		100/120	0.4	4	4.94	0.50												
LPGA300	L	3.00k { 306 }	25/30	0.4	1	6.59	0.67	1000				*1				*1	*1	*2	
LPGB300																			
LPGC300																			

Note) 1. For LPGC070H and LPGC100H in the above table, the motor capacity is 0.2kW.

2. The rod rotating force of LPGC070H in the above table is 2.31N·m (0.24{kgf·m}), and the rod rotating force of LPGC100H is 3.29N·m (0.34{kgf·m}).

\*1. Only parallel type is available.

\*2. LPGC type is not available.

## Ball screw type standard model list

Model	Speed symbol	Rated thrust N { kgf }	Nominal speed mm/s 50/60Hz	Motor capacity kW	Rod movement per turn of manual shaft mm	Rod rotating force		Nominal stroke mm	Main body shape		Type		Option										
						N·m	{ kgf·m }		Straight	Parallel	Basic	With torque limiter	With thrust detection mechanism	Bellows	External LS	Position detection unit	I-type end fitting	Clevis fitting	Anti-rotation mechanism				
LPGA070	U	700 { 71.4 }	200/240	0.4	8	0.99	0.10	100				*1	*3			*1	*1	*2					
LPGB070																							
LPGC070																							
LPGA100	U	1.00k { 102 }	200/240	0.4	8	1.41	0.14	400				*1	*3			*1	*1	*2					
LPGB100																							
LPGC100																							
LPGA300	M	3.00k { 306 }	50/60	0.2	2	4.24	0.43	800				*1				*1	*1	*2					
LPGB300																							
LPGC300			H	67/80	0.4	2.67	4.24		0.43														

\*1 Only parallel type is available.

\*2 LPGC type is not available.

\*3. Cannot be used for press contact stopping at the U speed.

## Motor specifications

Type	Totally enclosed self cooling type with brake	
Output	Standard model list	
Number of poles	4 poles	
Power supply	Voltage	3 $\phi$ 200V/200V/220V
	Frequency	50Hz/60Hz/60Hz
Heat resistance class	B	
Time rating	S2 30min.	
Protection class	Totally enclosed outdoor type (IP55)	

1) Different voltage specifications other than the above, 400/440V are also available.  
 2) For motor current value and brake current value, refer to page 79.

## Painting color

TSUBAKI olive gray (Munsell 5GY6/0.5 or approximate color)

## Standards use environment

Model Environment	Ambient temperature	Relative humidity (non-condensing)	Impact resistance value	Installation altitude	Atmosphere
Outdoor type	-15°C to 40°C	85% or less	1G or less	1000m or lower above sea level	Normal outdoors

- 1) With use below freezing, the characteristics (current value and speed) of the cylinder may vary according to the effect of grease.
- 2) Cylinders with bellows are recommended in an excessively dusty location.
- 3) All models have a totally enclosed structure so that they can be used normally outdoors. Even so, however, an appropriate cover is required in such a hostile environment that is splashed with water or vapor or in such a location where snow accumulates. For use at 40°C or higher, always protect with a heat-insulating cover, etc. Never use in a flammable atmosphere. Doing so may cause an explosion or fire. In addition, avoid using in a location subjected to vibration or impact exceeding 1G.
- 4) For use in a misty atmosphere, contact us.

## Structure

**LPGA: Basic type**

- Straight
- Parallel

**LPGB: With torque limiter**

- Parallel

\* The LPGB type is available only in parallel type due to the mechanism.

**LPGC: With thrust detection mechanism**

- Straight
- Parallel

## Classification of usage according to type (protection device)

The power cylinder G series includes the following three types. Each of these can be selected so that optimum functions can be fully exerted depending on application. The three types of power cylinders have the same performances (thrust, speed, stroke).

**LPGA (basic model)** — This type has a stop function with a brake only. Note that use exceeding the nominal stroke may result in breakage. When using this type, sensor for stroke regulation must be installed or optional external limit switch for stroke adjustment must be used. (The other two types similarly require a sensor for stroke adjustment.)  
When detecting abnormalities, combination with an electric protection device is recommended. A shock relay and shock monitor are available as electric protection devices.

**LPGB (with torque limiter)** — When any overload phenomena occurs and the set thrust is exceeded, the built-in torque limiter slips to exert the protecting function. However, long time slip generates heat on the motor, resulting in burnout, or reduces the transmissible torque, resulting in malfunction of the cylinder. Therefore, usage in combination with our shock relay is recommended.  
**\* Only parallel type is available.**

**LPGC (with thrust detecting mechanism)** — A type with a thrust detecting mechanism in combination with a pre-loaded spring and a limit switch. This mechanism exerts an effect in the following cases.  
① When press (pull) and stop are performed.  
② When an electric signal is required at overload.  
③ When an overload is possibly applied from the load side during stoppage.  
The built-in spring absorbs deflection impact load for impact within the rating.  
**\* Cannot be used for press contact stopping at the mechanical stroke end.**

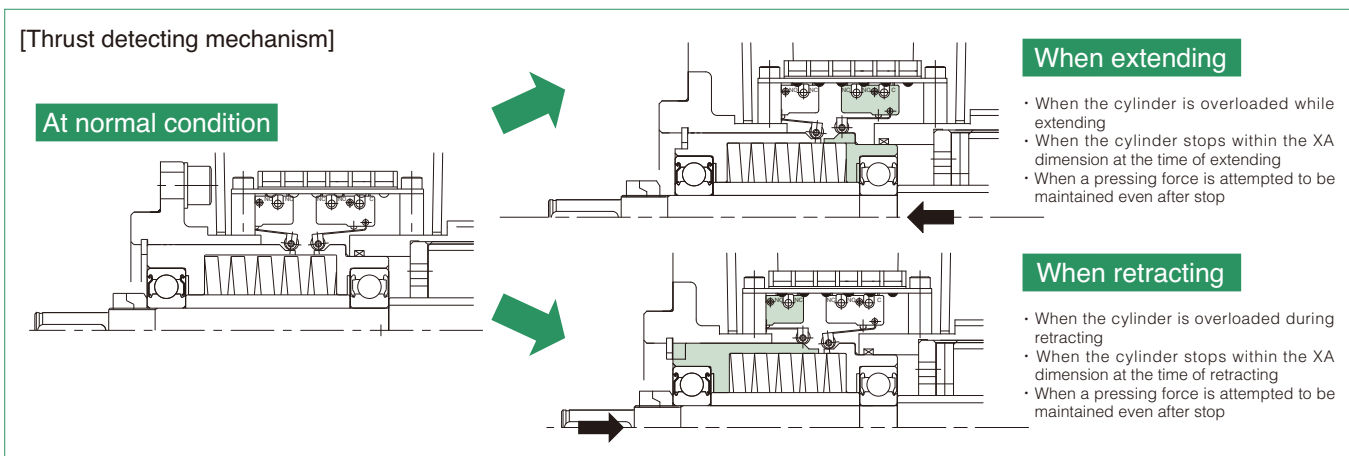

## Preset load for protection device

Preset loads for protection devices of the GB type and GC type are as follows.

The protection device does not work at the start for opening/closing of the damper or the hopper gate, normal reverse, inclination and elevation, however, when load inertia is large due to horizontal movement of the carriage, the protection device works to impair smooth operation at the start. When load inertia exceeds values shown in the table below, take countermeasures such as slow start operation by the inverter, etc.

### <Operation preset load for protection device>

GB (with a torque limiter): 150% to 200% of rated thrust

GC (with a thrust detecting mechanism): 140% to 200% of rated thrust

\* Use the above values as a guide.

### <Allowable mass in consideration of inertia at the time of horizontal drive> Unit: kg

Speed	Model	LPGA070	LPGA100	LPGA150	LPGA300
		LPGC070	LPGC100	LPGC150	LPGC300
L		1150	2085	1220	2060
M		170	280	310	1560
H		130	240	270	790
U		71	102	—	—

Mass of carriage:  $M$  kg  
Coefficient of friction:  $\mu$   
Carriage traveling resistance:  $F = \mu M \leq \text{Rated thrust}$

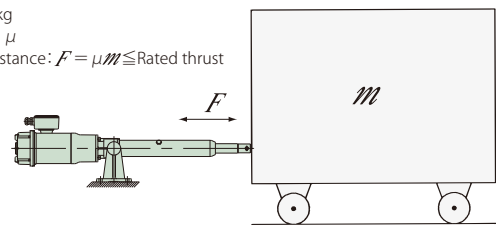

## Cautions for use

### ① When installing rotary encoder or potentiometer

For the LPGC type, a spring mechanism is built in the operating part. The spring slightly deflects at press (pull) and stop, or when an overload occurs, the signal amount deviates by the deflection. For LPGB type, even if the safety device is tripped, the signal amount does not deviate. However, the LPGC type can be used at normal stroke operation.

### ② When there is a problem with movement of the rod even if overload is applied from the load side during stop

For the LPGC type, a spring mechanism is built in the operating part, therefore, when a large load is applied, the spring deflects and the rod moves by the deflection. When the load is eliminated, the rod returns to the original position.

### ③ When using with press (pull) and stop, strength of the mating device shall be 250% of the rated thrust or more.

### ④ When the LPGC type is used, the time lag should be 0.03s or less.

## Selection 1

### Conditions of use required for selection

- |                                       |  |   |
|---------------------------------------|--|---|
| 1. Machine to be used and application | 4. Speed mm/s                                    | 7. Type of load of machine used                       |
| 2. Thrust or load N { kgf }           | 5. Frequency of operation, number of starts/min. | 8. Environment of use                                 |
| 3. Stroke mm                          | 6. Power source voltage, frequency               | 9. Hours of operation a day and annual operating days |

### Selection procedures

- Select the suitable model number from the standard model list (page 67) based on thrust, load N { kgf }, speed (mm/s), and stroke (mm).
- Determine the shape (straight or parallel) of the main body suitable for the installing condition, necessity of protection device and option from the machine used and use conditions.
- Check that the frequency of operation and the working time rate are within the allowable values of the cylinder.

#### Frequency of operation and the working time rate

Allowable start cycle	10 cycles/min. or less
Allowable duty factor (%ED)	25

$$\text{Working time rate (\%ED)} = \frac{\text{operating time of 1 cycle}}{\text{Operating time of 1 cycle + dwell time}} \times 100\%$$

The working time rate is a ratio of the operating time per 10 minutes on a 10-minute basis.

### Guide for life

#### <Expected traveling distance of trapezoidal screw type>

25km in cylinder (nut) traveling distance

#### <Expected traveling distance of ball screw type>

The life of a ball screw is determined by flaking of the rolling surface caused by its fatigue. Check the rough life with this chart of expected traveling distance. However, in the case of great impact or in the case where lubrication or maintenance is not performed properly, the expected traveling distance becomes substantially short.

$$\text{Expected traveling distance (km)} = \frac{\text{actual load stroke (m)} \times \text{frequency of use (times/day)}}{\text{number of operating days} \times 10^{-3} \times \text{expected number of years}}$$

The chart on the right-hand side is based on L10 life. L10 life expresses in traveling distance a life that can be reached by 90% or more of all ball screws. If you select a power cylinder based on the life, select model No. from this chart.

If the load greatly fluctuates in the middle of stroke, calculate the equivalent load ( $P_M$ ) by the equation on the right-hand side.

$$P_M = \frac{P_{MIN} + 2 \times P_{MAX}}{3}$$

$P_M$  : Equivalent load N { kgf }  
 $P_{MIN}$  : Minimum load N { kgf }  
 $P_{MAX}$  : Maximum load N { kgf }

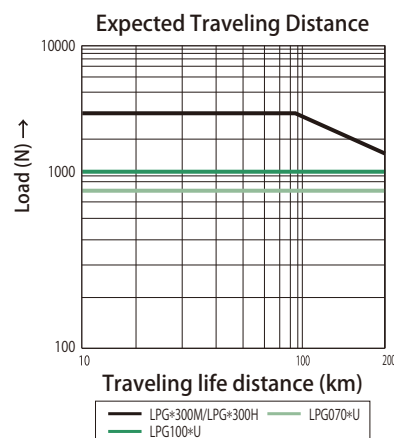

### Brake holding force

A load holding force while the power cylinder stops is exerted more than the rated thrust, therefore, it can be used for holding a load of the rated thrust. This holding force is generated by braking operation of the brake motor. The brake is of a spring braking type that always performs braking operation by a spring force during stop, and the brake torque has a holding force of 150% or more of the motor rated torque. The expected life of the brake is 2,000,000 times. However, gap adjustment is required.

\* When selecting the H, U speed, refer to the cautions for selecting on page 84.

\* Select a power cylinder of a sufficient thrust, allowing for a safety rate so that the loads used (static and dynamic) do not exceed the rated thrust.

## Selection 2

Refer to the following cylinder characteristics data to check that the cylinder is suitable for the application.

#### <Coasting distance and stop accuracy>

Coasting amount and stop accuracy vary depending on the operation speed and load. When you attempt to correctly position, cylinders with low operation speed are recommended. Set the limit switch in consideration of the coasting distance. Refer to the cautions for selecting on page 84.

Reference values of the coasting distance and stop accuracy are shown in the following table.

#### Coasting distance and stop accuracy (Reference values) (When relay time lag is assumed to be 0.03 seconds)

Usage		Unit: mm							
		Lifting load (In the case of 1 or 3)				Suspended load (In the case of 2 or 4)			
		50Hz		60Hz		50Hz		60Hz	
Model	Coasting distance	Stop accuracy	Coasting distance	Stop accuracy	Coasting distance	Stop accuracy	Coasting distance	Stop accuracy	
LPGA070 LPGB070 LPGC070	L	6.9	±0.4	10.0	±0.5	10.6	±0.4	14.9	±0.5
	M	15.0	±1.1	21.5	±1.3	21.8	±1.2	30.1	±1.4
	H	15.4	±1.4	21.7	±1.7	23.7	±1.5	32.7	±1.8
	U	34.2	±2.8	47.9	±3.4	60.6	±3.1	81.2	±3.8
LPGA100 LPGB100 LPGC100	L	6.1	±0.4	9.0	±0.5	10.6	±0.4	14.9	±0.5
	M	13.8	±1.1	19.8	±1.3	22.1	±1.2	30.5	±1.4
	H	14.1	±1.4	19.8	±1.7	23.8	±1.5	32.7	±1.8
	U	32.0	±2.8	45.0	±3.4	66.9	±3.1	88.2	±3.8
LPGA150 LPGB150 LPGC150	L	4.6	±0.4	6.6	±0.5	7.1	±0.4	9.8	±0.5
	M	10.6	±1.1	14.7	±1.3	15.6	±1.2	21.3	±1.4
	H	13.7	±1.4	19.0	±1.7	21.8	±1.6	30.0	±1.9
	U	32.0	±2.8	45.0	±3.4	66.9	±3.1	88.2	±3.8
LPGA300 LPGB300 LPGC300	L	3.3	±0.4	4.6	±0.5	5.1	±0.4	6.9	±0.5
	M	8.6	±0.8	12.4	±0.9	23.2	±0.8	29.4	±1.0
	H	9.4	±1.0	13.1	±1.2	19.0	±1.1	25.0	±1.3
	U	32.0	±2.8	45.0	±3.4	66.9	±3.1	88.2	±3.8

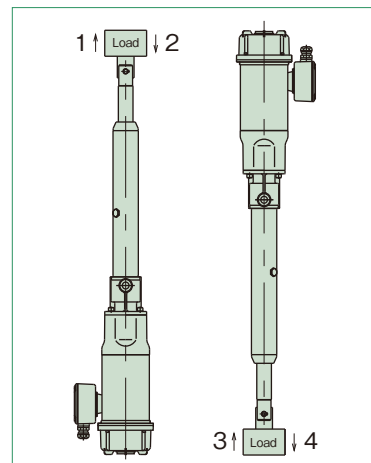

\* The values in the above table slightly vary depending on the models.

\* Coasting distance: This indicates a distance from a time when the limit switch or the stop button is operated until the cylinder stops. This coasting distance varies depending on how a load is applied and the operation circuit.

\* Stop accuracy: This indicates a variation in the stop position when stop is repeated.

The above table takes ±25% of time lag of the relay and the brake into consideration.

\* An anti-rod rotation mechanism is required.



## Dimensions Table Straight type

### LPGA070~300□T (Basic type)

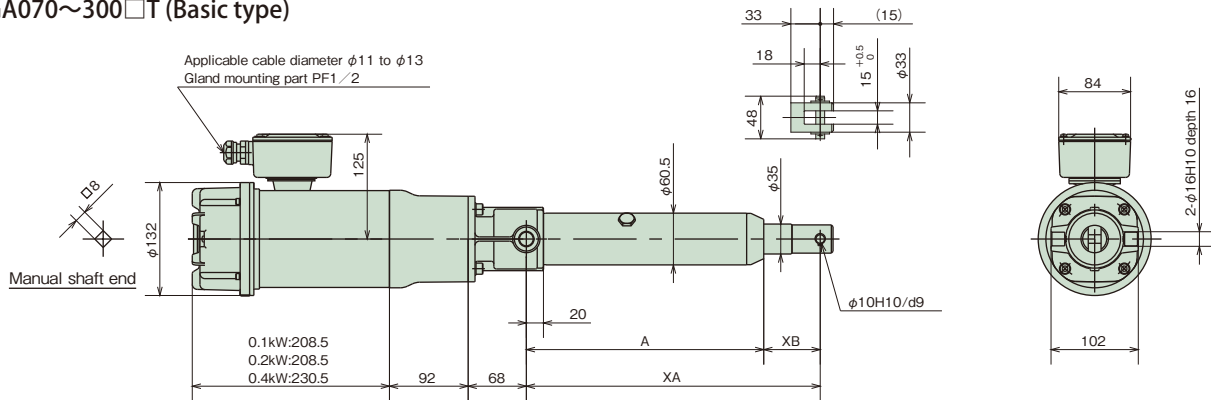

### LPGC070~300□T (With thrust detection mechanism)

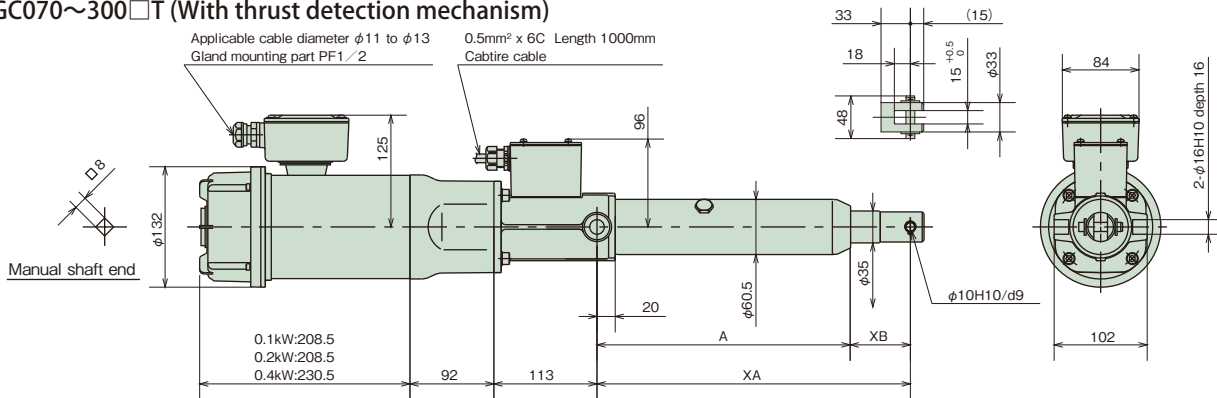

Unit: mm

Model	Speed symbol	Shape of main body	Nominal stroke	A	XA		XB		Approx. mass (kg)		
					MIN	MAX	MIN	MAX	LPGA	LPGC	
LPGA LPGC	070 100 150 300	L M H U	T	100	178	243	343	65	165	14	18
				200	278	343	543	65	265	15	19
				300	378	443	743	65	365	16	21
				400	478	543	943	65	465	18	22
				500	578	643	1143	65	565	19	23
				600	678	743	1343	65	665	20	24
				800	878	963	1763	85	885	22	26
				1000	1078	1183	2183	105	1105	24	28
			1200	1278	1403	2603	125	1325	27	31	

Note) 1. The mechanical stroke includes a margin of 3 to 8 mm of the nominal stroke on both sides.

2. For U speed, only 070 and 100 are applied.

## Options

### External LS ( - L)

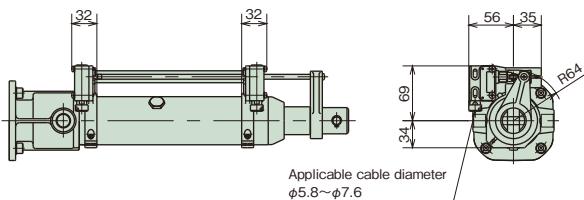

### Bellows ( - J)

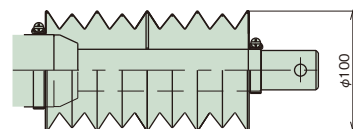

### Trunnion fitting (LPGA300-T)

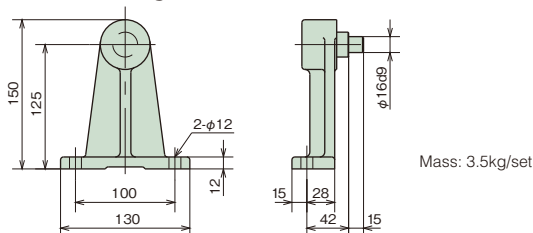

Note) Apply grease to the trunnion pin and into the trunnion hole for installation.

### I-type end fitting ( - I)

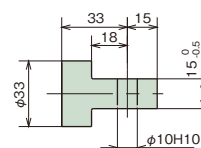

Note) Shipped as attached to the main body.  
The XA dimensions are the same as the standard U-type end fitting.

\* Dimensions with no tolerance described have general tolerance, and their sizes become larger by approximately 2 to 5mm from the described dimensions. When designing the machine, take margins into consideration.

Horizontal dashed lines for writing.

## Dimensions Table Parallel type

LPGA070~300□K (Basic type)

LPGB070~300□K (With torque limiter)

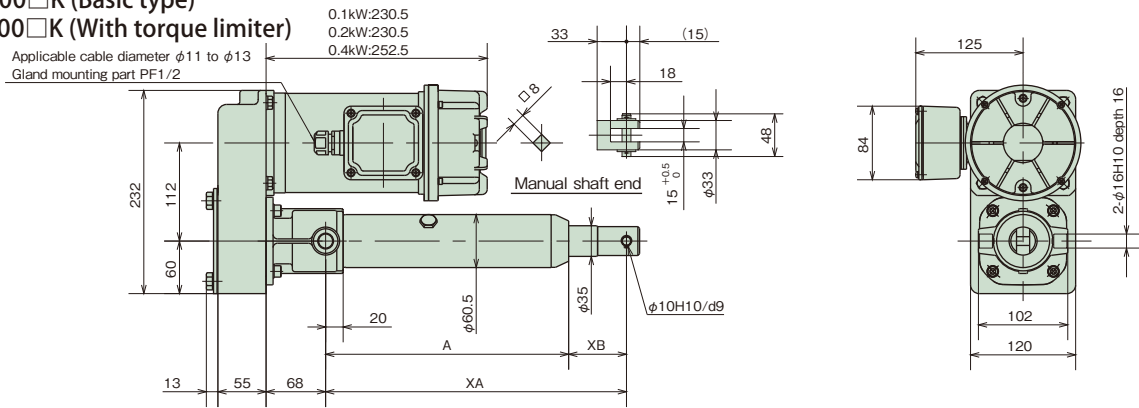

LPGC070~300□K  
(With thrust detection mechanism)

Applicable cable diameter  $\phi 11$  to  $\phi 13$   
Gland mounting part PF1/2

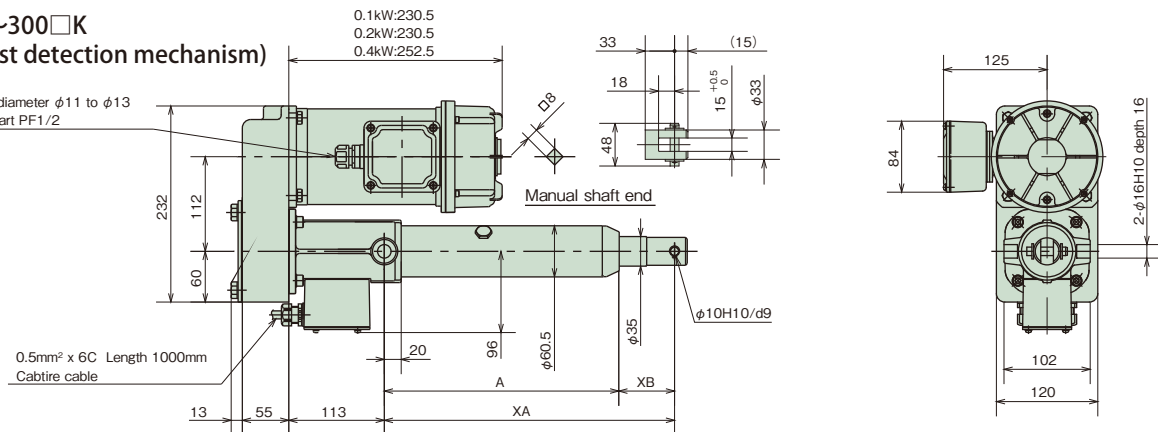

Unit: mm

Model	Speed symbol	Shape of main body	Nominal stroke	A	XA		XB		Approx. mass (kg)			
					MIN	MAX	MIN	MAX	LPGA	LPGB	LPGC	
LPGA LPGB LPGC	070 100 150 300	L M H U	K	100	178	243	343	65	165	18	18	23
				200	278	343	543	65	265	19	19	24
				300	378	443	743	65	365	21	21	25
				400	478	543	943	65	465	22	22	26
				500	578	643	1143	65	565	23	23	27
				600	678	743	1343	65	665	24	24	28
				800	878	963	1763	85	885	26	26	31
				1000	1078	1183	2183	105	1105	28	28	33
			1200	1278	1403	2603	125	1325	31	31	35	

Note) 1. The mechanical stroke includes a margin of 3 to 8 mm of the nominal stroke on both sides.  
2. For U speed, only 070 and 100 are applied.

## Options

### External LS ( - L)

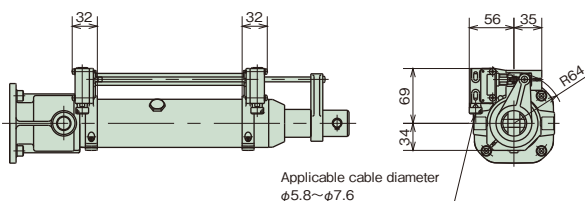

### Bellows ( - J)

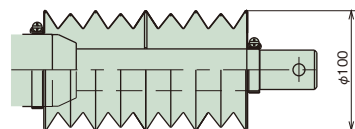

### Trunnion fitting (LPGA300-T)

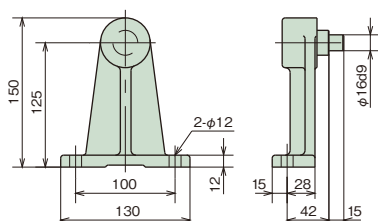

Note) Apply grease to the trunnion pin and into the trunnion hole for installation.

### I-type end fitting ( - I)

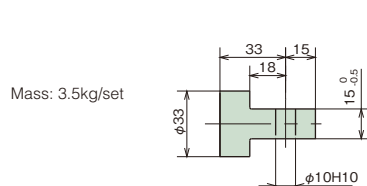

Note) Shipped as attached to the main body. The XA dimensions are the same as the standard U-type end fitting.

### Clevis fitting ( - C)

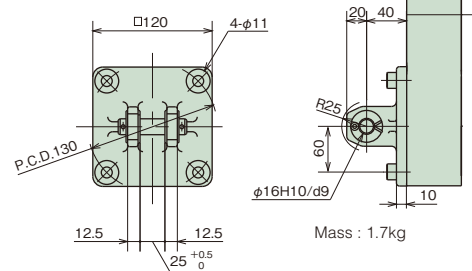

\* Dimensions with no tolerance described have general tolerance, and their sizes become larger by approximately 2 to 5mm from the described dimensions. When designing the machine, take margins into consideration.

Horizontal dashed lines for writing.

## Position detecting unit

The following three types of the position detecting device can be built in the position detecting unit at your request.

### 1. Position detecting internal LS (with two or four pieces)

### 2. Potentiometer

### 3. Rotary encoder

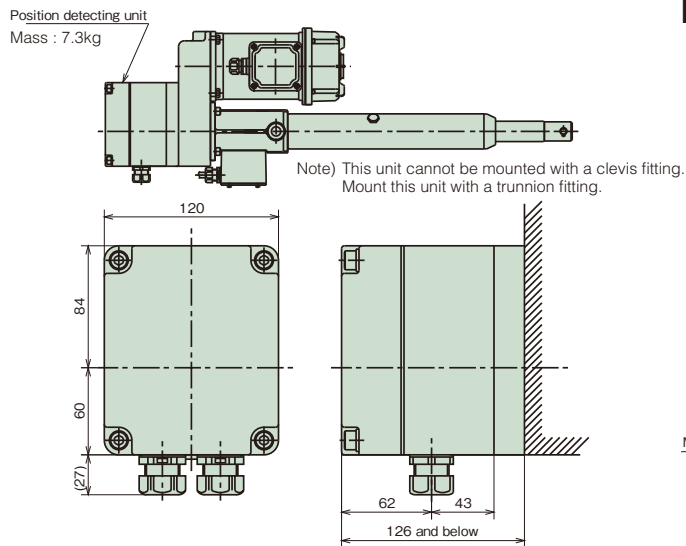

### Internal structure

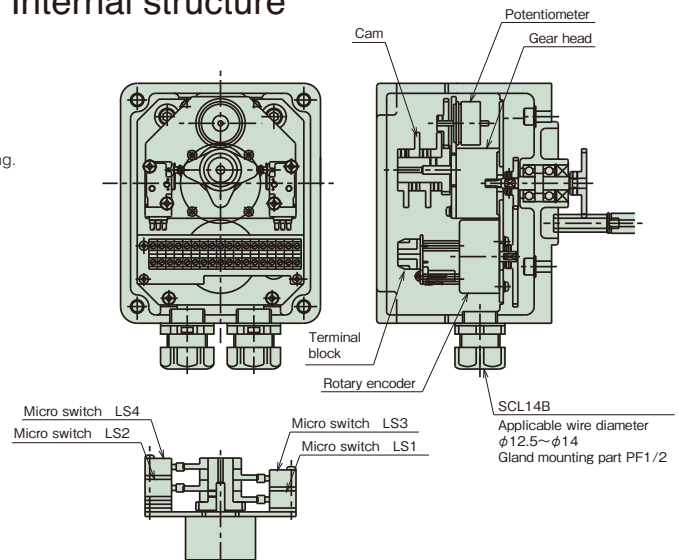

#### Wire connection into position detecting unit

Use terminals provided in the unit to connect to the internal limit switch, potentiometer and rotary encoder. COM for the internal limit switch is common. (internally wire-connected)  
Use shield wire for wire-connection to the rotary encoder.

Terminals for power cylinder wiring

Terminals for device wiring

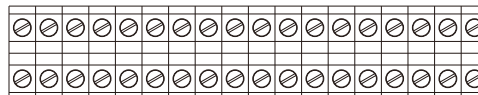

Terminal No. 1 2 3 4 5 6 7 8 9 10 11 12 13 14 15 16 17 18

Option	Internal limit switch (K2, K4)								Potentiometer			Rotary encoder						
Symbol	LS1		LS2		LS3		LS4		Common	P		R						
Contact	a	b	a	b	a	b	a	b	c	1	2	3	1	2	Z	5V~24V	0V	Case
Terminal No.	18	17	5	6	16	15	7	8	4	1	2	3	9	10	11	12	13	14

### 1. Position detecting internal LS (with two or four pieces)

Use this LS when the external LS cannot be installed due to the installation space or when performing operation in combination with the potentiometer or the rotary encoder.

With two pieces: Optional symbol K2 Arrangement of LS1 and LS2 in the above figure.

With four pieces: Optional symbol K4 Arrangement of all of LS1 through 4 in the above figure.

#### <Setting of LS>

First, before installing a power cylinder to the equipment, operate the cylinder in a single unit to check the rotating direction of the LS cam.

Intall the equipment to the power cylinder, stop the power cylinder, or, move it to a position where you would like to have it be detected.

Then, rotate the LS cam, and tighten the hexagon socket head set screw to fix at a position where the micro switch operates.

At this time, estimate a coasting amount of the power cylinder depending on the pre-checked rotating direction.

Micro switch specification	
Model	OMRON D2VW-5L2A-1M or equivalent
Circuit configuration	NC (Red)  COM (Black)
Electric rating	250V AC 4A (cos $\phi$ 0.7)
Connection	Terminal block connection in position detecting unit

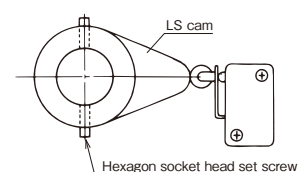

## Position detecting unit

### 2. Potentiometer

This is a variable resistor to output electric signals depending on the stroke amount of the power cylinder. Use this unit in combination with TSUBAKI TC unit, or print board and stroke indication meter. Resistance values according to the model have been adjusted before shipment.

Separately request preset values according to the model as they are described in the position detecting unit specification drawing. Pay strict attention to handling because correspondence between the stroke position and the resistance value will deviate by rotating the rod of the power cylinder.

Potentiometer specifications	
Model	CP-30 or equivalent
Manufacturer	SAKAE TSUSHIN KOGYO CO., LTD.
Total resistance	1kΩ
Rated power	0.75W
Dielectric strength	1000V AC 1min.
Effective electric angle	355° ± 5°
Effective mechanical angle	360° endless
Connection	Connected to terminal block in position detecting unit

### 3. Rotary encoder

Rotary encoder specifications		
Model	TS5305N251	
Manufacturer	Tamagawa Seiki Co., Ltd.	
Output pulse number	600P/R	
Output waveform	90° phase difference two-phase square wave + home position output	
Output voltage	H	— Note 1)
	L	1V or less Note 1)
Power supply	5~24V DC	

The output signal of the standard specification is of an incremental type, however, an absolute type is also available.

The output type in standard specifications is an open collector.

If voltage output type is required, see (Note 1) below.

If the specification of line driver output is required, contact us.

Note 1) Due to the open collector output, output signals are obtained when the pull-up resistor is connected.

Signal 1 and signal 2 are output voltages of H "(power supply voltage - 1)V or more" and L "1V or less."

For the Z-phase, negative logic applies.

<Reference resistance values> 5V: 220Ω, 12V: 470Ω, 24V: 1kΩ

#### Output connection

Signal 1	Signal 2	Signal Z	+5V to 24V	0V	Case
(9)	(10)	(11)	(12)	(13)	(14)

Figures in parentheses indicate terminal No.

#### Output waveform

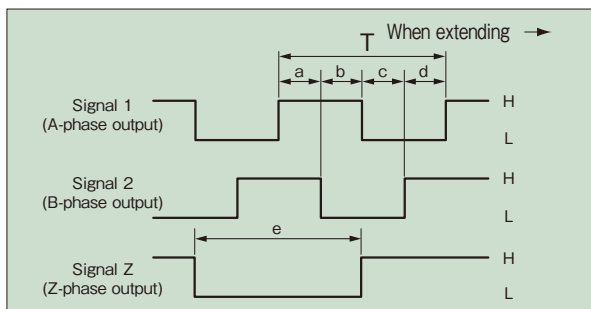

a. b. c. d =  $T/4 \pm T/8$   $T/2 \leq e \leq 3T/2$

#### Output circuit

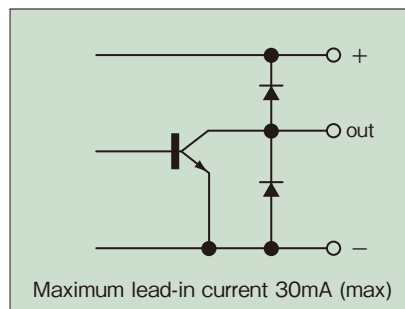

\* Best suited to controlling the stroke by a sequencer or programmable controller, etc.

More accurate positioning control is possible in combination with motor speed control by an inverter, etc.

- ① The standard products incorporate an incremental type encoder.
- ② The rotary encoder has been set to output 20 pulses per stroke of 1mm.
- ③ It is possible to set an accurate home position of the machine in combination with a limit switch because home position output is read out every 600 pulses.
- ④ Do not apply vibration or impact to the rotary encoder because it is precision equipment.
- ⑤ Use shield wire for wiring to the rotary encoder.
- ⑥ As a guide for the distance between the rotary encoder and control panel, a collector current of 20mA should be able to be transmitted approximately 50m (12V pull-up).

For distances other than the above, consult with us.



## Control option

### For potentiometer

#### Stroke indication meter

This meter indicates a stroke in % by a signal from the print board.

Model	RM-80B(100 $\mu$ A DC) or equivalent
Grade	JIS C 1102 2.5 class
Appearance	Frame • black
Scale specification	Entire stroke is indicated in 100%

\* A separate printed board is also required.

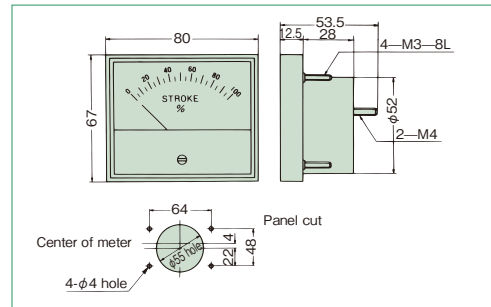

#### Printed board

This printed board converts voltage signals from the potentiometer in the position detecting unit of the power cylinder G series into current signals.

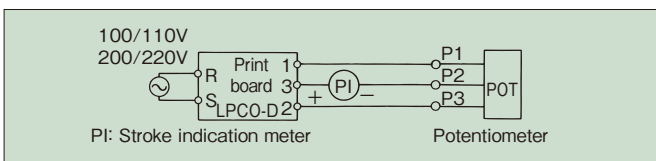

Adjust the meter with an ADJUST volume on the print board. Do not make a mistake with the stroke indication meter + and -. Replace the terminals 1 and 2 on the print board to set the indication meter to 100% when the stroke is MIN.

Model LPCO-D1 (Operation power 100/110V 50/60Hz)

LPCO-D2 (Operation power 200/220V 50/60Hz)

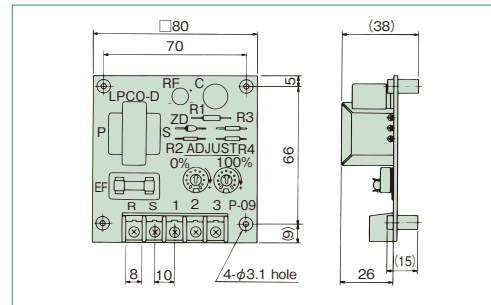

#### R controller

This controller converts voltage signals from the potentiometer in the position detecting unit of the power cylinder G series into digital signals, and performs indication and stroke control. This controller incorporates a scaling function, and can indicate real strokes or extension (%).

This R controller can be directly connected to the potentiometer.

Model	RX-5455-NBAS (BURRUF) or equivalent
Total resistance value of input potentiometer	0.8k $\Omega$ ~12k $\Omega$
Indication	4 digits 7 segment LED
Appearance	Black
Comparison output	HI, LO, GO (Relay output)
Comparison preset value	0— $\pm$ 9999
Comparison output contact capacity	30V DC/1A 250V AC/0.2A
Output contact configuration	1C (for all of HI, GO, LO sides)
Power supply	200V AC $\pm$ 10% 50/60Hz

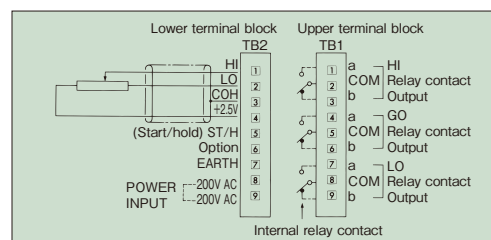
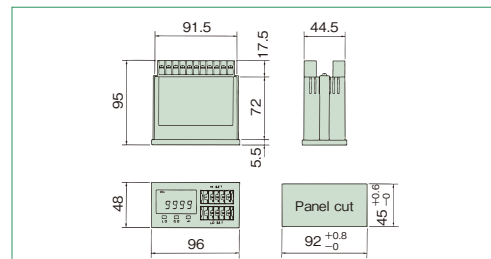

#### Meter relay

Used for simple adjustment of stroke on the operation panel.

( Iron panel attachment is standard.  
Contact us separately when installing an aluminum panel. )

Note) For using 4—20mA output, designate as "for 4—20mA output."

Meter relay specification	
Model	NRC-100HL (TSURUGA) or equivalent
Grade	JIS C 1102 2.5 class
Appearance	Frame • black
Scale	Entire stroke is indicated in 100%
Power supply	100/100V AC, 200/220V AC 50/60Hz
Input	Max. 100 $\mu$ A DC
Output contact configuration	For both of HIGH, LOW sides 1C (See the right Fig.)
Contact capacity	250V AC 3A ( $\cos\phi=1$ )

\* A separate printed board is also required.

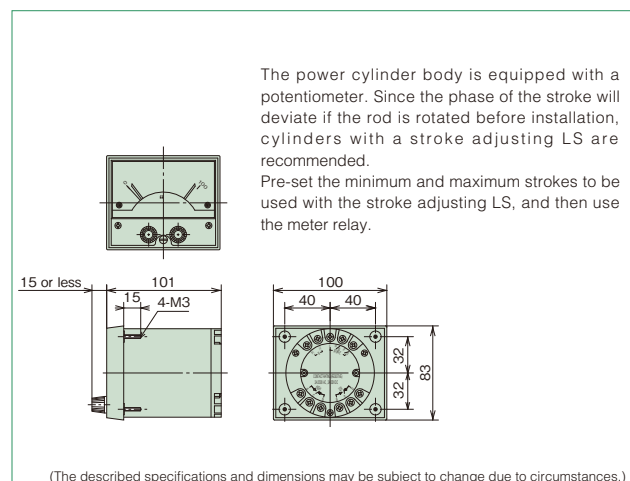

## Control option

### <Printed board>

This is the same as the printed board for the stroke indication meter.

### <Relay operation> (In the case of b contact)

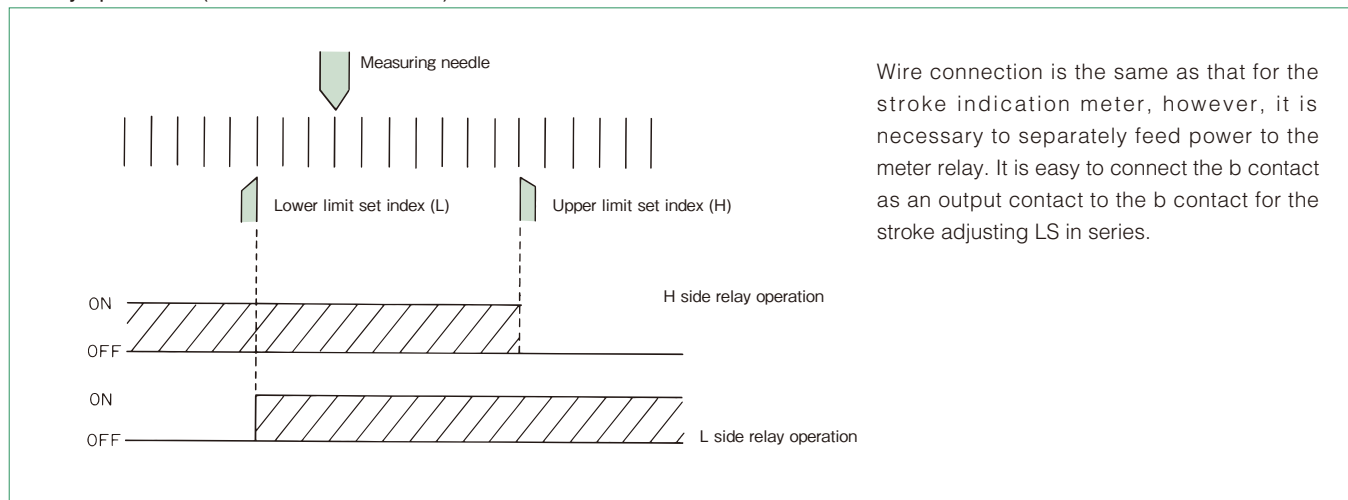

Wire connection is the same as that for the stroke indication meter, however, it is necessary to separately feed power to the meter relay. It is easy to connect the b contact as an output contact to the b contact for the stroke adjusting LS in series.

## Shock relay

Our highly reliable shock relay is recommended as an electric safety device for the GB type power cylinder. For details, refer to the "TSUBAKI E&M SAFCON overload protection devices and control devices catalogue."



Shock relay TSBSA series  
(Economy, automatic reset type)



Shock relay TSBSS series  
(Economy, self-holding type)



Shock relay TSBED series  
(Digital indication, self-holding/automatic reset type)

## Wire connection

### Wire connection for brake motor (motor with DC brake)

#### Brake internal wiring

200V class

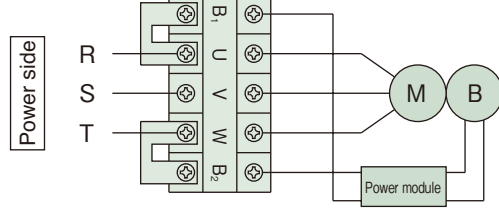

400V class

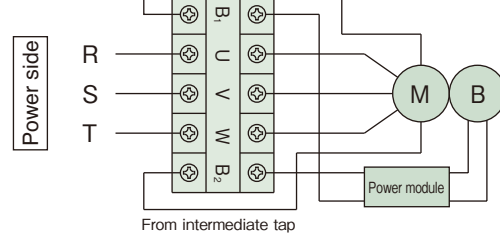

#### Brake external wiring

200V class

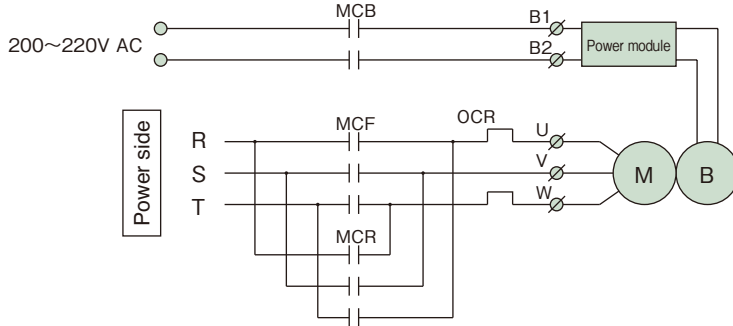

400V class

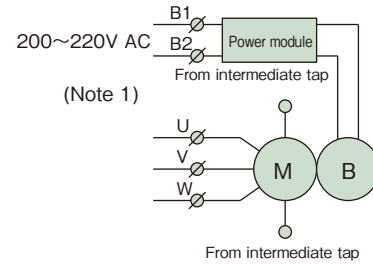

Note) 1. When AC external wiring in the three-phase 400V class motor, make sure to insulate the wire from the intermediate tap. In this case, input power supply to the power module requires 200 to 220V. If no power of 200 to 220V is supplied, decrease the voltage to 200 to 220V by a transformer.

If a voltage of 230V or more is directly input to the power module, the brake and the power module may burn out.

The capacity of the transformer shall be 90VA or more (0.1 to 0.4kW), and check that there is no voltage drop.

Use an MCB with a contact capacity of 250V AC, 7A or more.

The power module includes a surge absorbing protection element. Add a protection element for the contact in each part if necessary.

2. Do not put a relay contact on the output side of the standard power module (between the power module and brake coil). (Do not perform DC external wiring.)

3. By the above connection, the rod retracts in a straight type, and the rod extends in a parallel type.

\* Crimp contact bolt: M4

\* For the other details, refer to the Operation Manual.

## Limit switch specification

	Stroke adjusting external LS	Thrust detecting LS
Model	OMRON D4E-1B20N or equivalent	OMRON SS-5GL2D or equivalent
Circuit configuration		
Electric rating	250V AC 3A (cosφ0.4)	250V AC 2A (cosφ=0.4)
Connection	M3 screw x3 Applicable cable diameter φ5.8 to φ7.6	0.5E x 6C Length 1000A Cabtire cable draw-out

## Motor current value, Brake current value

Output, frame No.	Motor current value (A)						Brake model	Brake current value (A)					
	200V 50Hz	200V 60Hz	220V 60Hz	400V 50Hz	400V 60Hz	440V 60Hz		200V 50Hz	200V 60Hz	220V 60Hz	400V 50Hz	400V 60Hz	440V 60Hz
4P - 0.1kW	0.72 (2.76)	0.62 (2.60)	0.65 (2.84)	0.36 (1.38)	0.31 (1.27)	0.32 (1.41)	SBH01LP	0.18 0.27	0.18 0.27	0.19 0.29	0.18 0.27	0.18 0.27	0.19 0.29
4P - 0.2 kW	1.3 (4.91)	1.1 (4.68)	1.1 (5.14)	0.63 (2.40)	0.55 (2.22)	0.56 (2.41)	SBH02LP	0.18 0.27	0.18 0.27	0.19 0.29	0.18 0.27	0.18 0.27	0.19 0.29
4P - 0.4 kW	2.4 (11.6)	2.1 (10.2)	2.1 (11.0)	1.2 (5.14)	1.1 (4.88)	1.1 (5.39)	SBH04LP	0.18 0.27	0.18 0.27	0.19 0.29	0.18 0.27	0.18 0.27	0.19 0.29

Note) 1. The above values are rated current values of the motor and brake. The numerical value in parentheses is a start current value of the motor.

2. The rated current values and start current values do not include brake current values.

3. A DC brake is used as a brake. The upper stage of the brake current value indicates a value on the primary side of the power module, and the lower stage indicates a value on the secondary side.

4. The above values are references because the rated current values for the power cylinder vary depending on the operating conditions.

5. For AC internal wiring of the 400V class, the voltage is converted to 200V through the motor intermediate tap to be input. For AC external wiring, decrease the voltage to 200 to 220V by a transformer. The capacity of the transformer shall be 90VA or more.

Reference circuit

200V Class GA type brake internal wiring reference circuit

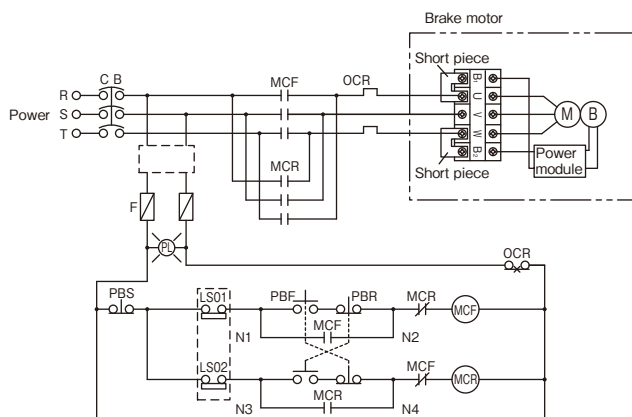

LS01: Extend stroke adjusting external limit switch  
 LS02: Retract stroke adjusting external limit switch

NOTE :

- (1) This diagram shows a single-acting circuit. When using in an inching circuit, remove the wire connection between N1 and N2, N3 and N4, and short-circuit the PBS.
  - (2) If the power voltage for the motor is different from the control voltage, put a transformer into a [ ] portion in the diagram.
  - (3) When AC external wiring the brake, remove the short piece on the terminal block and apply a normal power voltage (200 to 220V) to B1 and B2 from the outside.
- \* For wire connection when an inverter is used, refer to page 114.

400V Class GA type brake internal wiring reference circuit

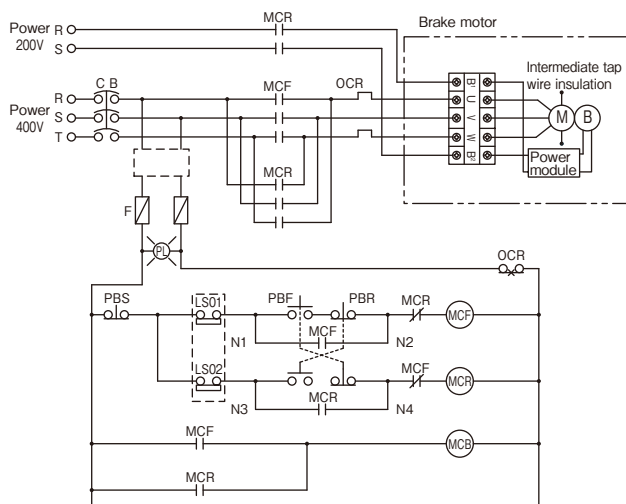

LS01: Extend stroke adjusting external limit switch  
 LS02: Retract stroke adjusting external limit switch

NOTE :

- (1) This diagram shows a single-acting circuit. When using in an inching circuit, remove the wire connection between N1 and N2, N3 and N4, and short-circuit the PBS.
  - (2) If the power voltage for the motor is different from the control voltage, put a transformer into a [ ] portion in the diagram.
  - (3) When AC external wiring the brake, remove the wire connected to the terminal block from the motor intermediate tap and insulate it. Apply a normal power voltage (200 to 220V) to B1 and B2 (primary side of the module). If there is no power of 200V, decrease the voltage to 200V by a transformer. The capacity of the transformer shall be 90VA or more (0.1 to 0.4KW), and check that there is no voltage drop. Use a contact capacity of 250V AC, 7A or more.
- \* For wire connection when an inverter is used, refer to page 114.

0.1 – 0.4kW GA type brake internal wiring reference circuit for linkage of two

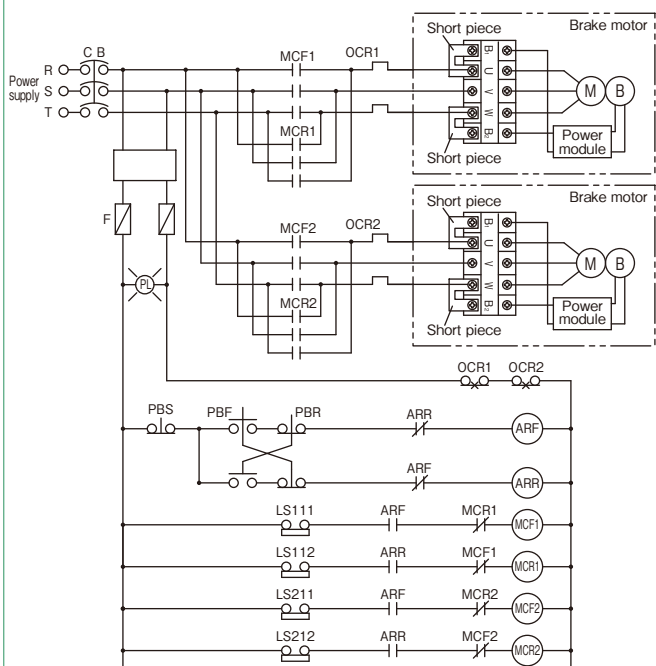

LS111: LP No. 1 extend stroke adjusting external limit switch LS1  
 LS112: LP No. 1 retract stroke adjusting external limit switch LS1  
 LS211: LP No. 2 extend stroke adjusting external limit switch LS2  
 LS212: LP No. 2 retract stroke adjusting external limit switch LS2

NOTE :

- (1) This diagram shows an example of 0.1 – 0.4kW brake internal wiring circuit for linkage of two in inching motion.
- (2) If the power supply voltage for the motor is different from the control voltage, put a transformer in the [ ] section in the diagram.
- (3) Lead wires B1 and B2 for the brakes are connected to U and W on the motor terminal block by using short pieces.
- (4) For using the brakes by external wiring, remove the short pieces, and externally apply not inverter output but normal power supply voltage to B1 and B2.

## Installation

### Installation direction

Either horizontal, vertical and inclined directions are allowed.

### Installation method

For installation of the main body, use a trunnion mount or clevis mount (parallel only).

Apply grease to the trunnion pins and bracket holes for mounting.

Install the end part with a U-type or I-type end fitting.

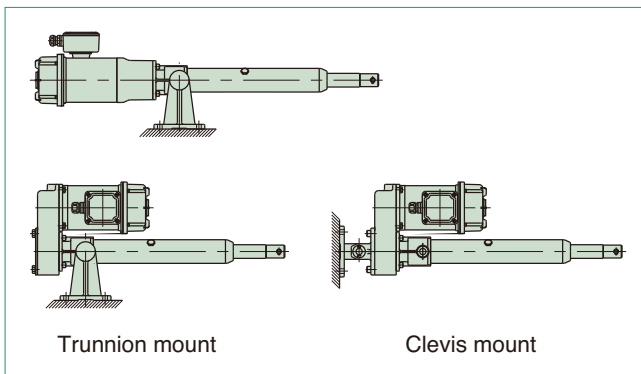

### Manual operation

When manually adjusting the stroke, rotate the manual shaft on the motor opposite load side with the manual handle after releasing the brake. For how to release the brake, refer to the Operation Manual. The manual handle is attached to the product.

#### ⚠ WARNING

When a load is applied to the rod, remove the load before releasing the brake.

For the amount of movement of the rod per one turn of the manual shaft, refer to the standard model list (page 67).

### Anti-rod rotation

1. Anti-rod rotation is required because a rotating force is generated on the rod with thrust. Generally, rotation can be mainly prevented by installing the rod end to a driven machine.
2. When operating with the end set free or installing pulleys to pull a rope, use a rod anti-rotation specification (option symbol M).

### Setting of stroke adjusting external LS

1. Take the coasting amount (page 70) into consideration to set adjustment of the limit switch.
2. When using the cylinder at the nominal stroke, set the limit switch so that the cylinder stops within the XA dimension in the Dimensions Table.
3. When synchronized operating two or more power cylinders, install a limit switch at the extend limit and retract limit on each cylinder to stop each cylinder. Avoid controlling all power cylinders with one limit switch because accumulated errors in stroke will occur. For the control circuit, see the example of circuit for linkage on page 80.

## Maintenance

### Greasing on screw

Use the screw as it is because it has been applied with greased in advance. Refill grease with reference to Table 1-2 as a guide. To apply grease to the screw, remove the greasing port bolt on the outer cylinder and advance the rod in the full stroke and apply grease to the outer circumference of the screw with a grease gun, and then reciprocate the rod within the stroke to be used. Repeat this operation a few times.

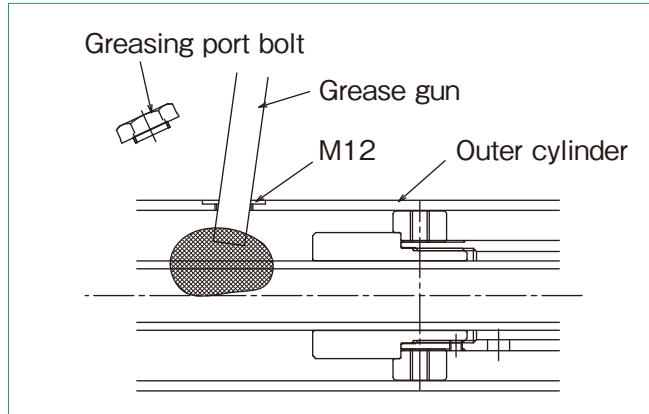

#### ⚠ WARNING

Never insert your finger into the greasing port.

If the cylinder operates with your finger inserted, your finger may be injured.

Table 1 Recommended grease

Use classification	Company name	Grease name
Screw shaft	TSUBAKI E&M	JWGS100G
	IDEMITSU KOSAN	*DAPHNE EPONEX SRNo.2
	NIPPON GREASE	NIGULUBE EP-2K
	EXXON MOBILE	MOBILUX EPNo.2
	COSMO OIL LUBRICANTS	COSMO GREASE DINAMX EPNo.2
	SHOWA SHELL	SHELL ALBANIA EP grease 2

\* The above greases are filled before shipment.

Note) JWGS100G is separately sold in a container of 100g. (See page 262.)

Table 2 Lubrication cycle

Lubrication cycle		
Traveling distance	Every 5km	
Operating frequency	100 times or more/day	One to three months
	10 to 100 times/day	Three to six months
	Up to 10 times/day	Six months to one year

Note) The above values are for longer use, and do not indicate life.

### Greasing on Reduction part

Grease has been applied on the tooth surfaces in advance, therefore, use the decelerating part as it is.

Initial tooth surface application grease

Planetary gear (straight type): Moly gear grease No. 1 (SUMICO LUBRICANT CO., LTD.)

Helical gear (parallel type): Moly gear grease No. 1 (SUMICO LUBRICANT CO., LTD.)

\* Apply grease to the helical gear part (parallel type) approximately once one year.

## Adjustment of external limit switch and variation of mounting

### 1. Standard Mounting Form

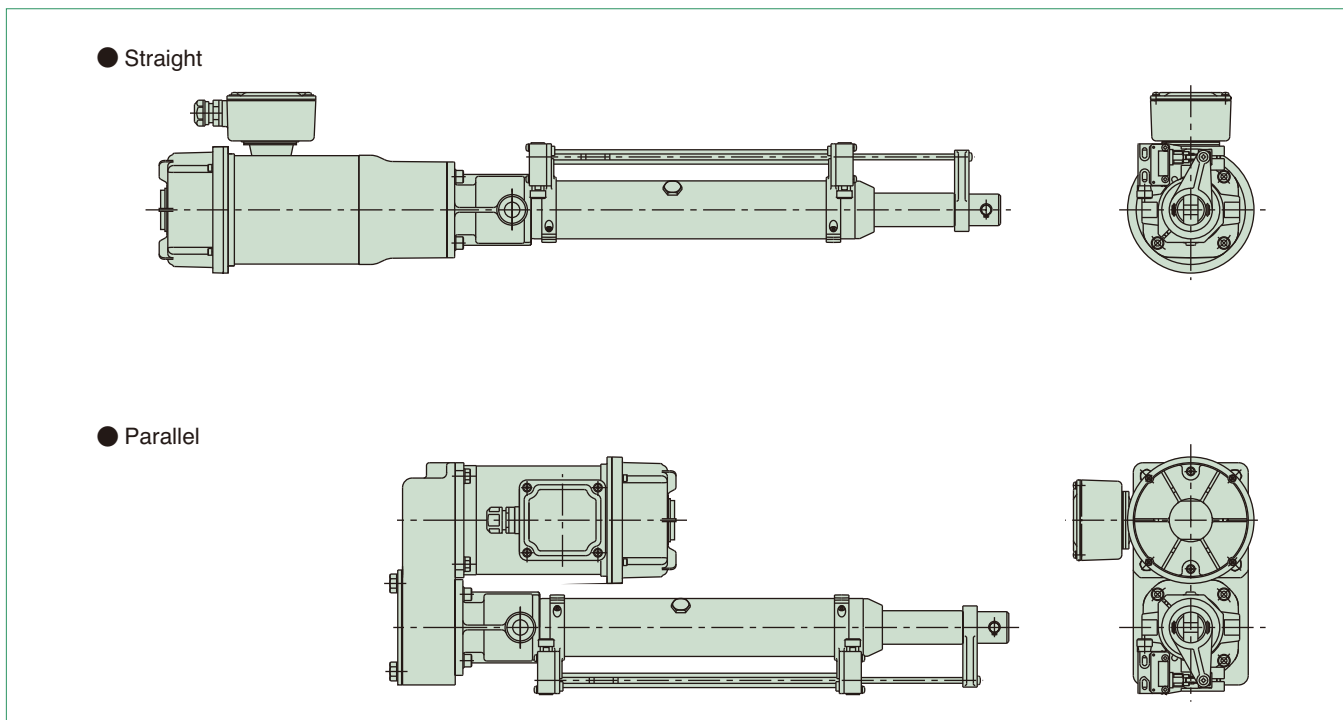

### 2. Adjustment method

The power cylinder G series has a margin of approximately 3 to 8mm of the nominal stroke on both sides which allows for mechanical stroke. The stroke to be used is within the nominal stroke, therefore, adjust the limit switch so that operation is made in this range. If the nominal stroke is exceeded, the striker protrudes from the LS guide rail. When adjusting the limit switches, adjust and fix the limit switches one by one so that the relative position between the LS guide rail and the cylinder body is not deviated.

#### <Adjustment method>

1. Loosen the LS flange tightening bolt (A) and the guide rail tightening bolt (B).
2. Slide the flange to a position where you want it set.
3. Tighten the guide rail tightening bolt (B) beforehand.
4. Check that the guide rail and the LS rod are not twisted, and tighten the LS flange tightening bolt (A).

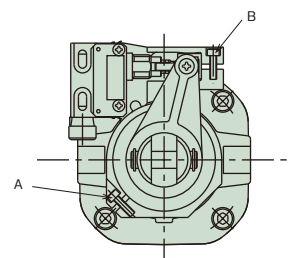

### 3. Mounting variations

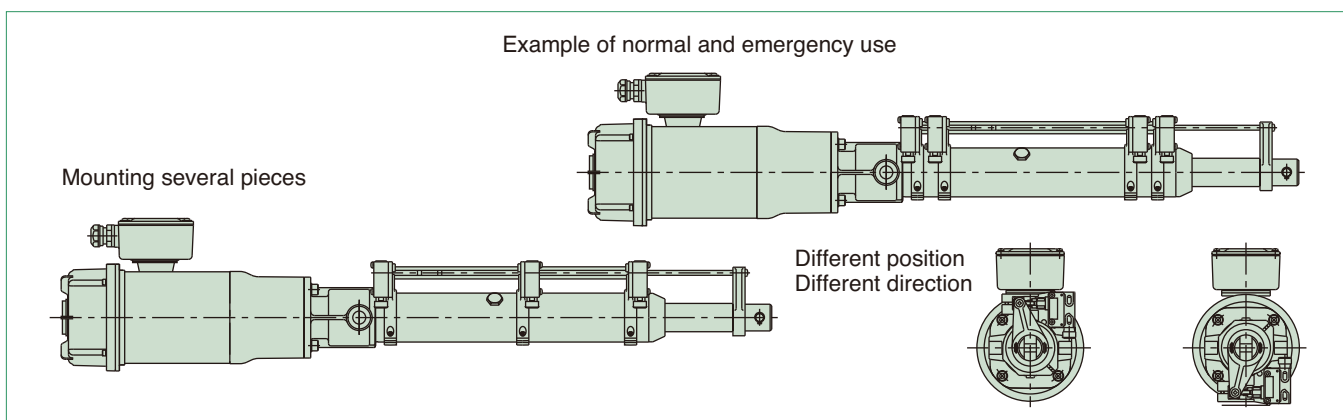

### 4. Change in mounting work

- For change in orientation and quantity, a separate Instruction Manual is available. Contact us.
- Either mounting direction is allowed, however, take the direction into consideration so that accumulation of dust or dirt the guide rail does not impair operation of the striker.



# Variation in direction and position of terminal box

## 1. "Direction" of motor terminal box

The motor terminal box can be fixed in four directions shown in the following diagram.

This direction can be easily changed by the customer.

Be aware that if the lead wires are pulled or bent forcefully, the wires will be broken.

Procedures to change are as follows.

1. Remove the lid of the terminal box.
2. Remove the two screws fixed to the terminal block.
3. Bring up the terminal block without removing the wire connection for the motor and the brake, and remove the four screws fixed to the terminal box.
4. Rotate the terminal box in the desired direction and re-fix it to the main body.
5. Install the terminal block again.

Be aware that if the lead wires are trapped under the terminal block, the wires will be broken or an insulation failure will occur.

6. After connecting the power cable, install the lid, then the procedures are completed.

When fixing the terminal box to the main body, check that the rubber packing is correctly sandwiched, then firmly tighten the four screws.

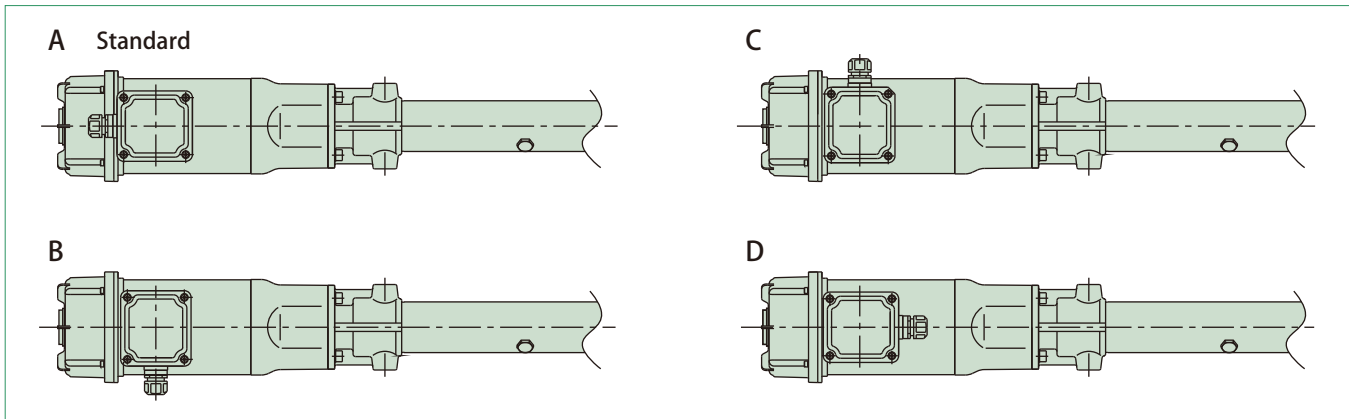

## 2. "Position" of motor terminal box

The position of the motor terminal box can be rotated by every 90 degrees around the motor shaft as shown in the following diagram.

However, this change must not be carried out by the customer. Specify the position when ordering the power cylinder.

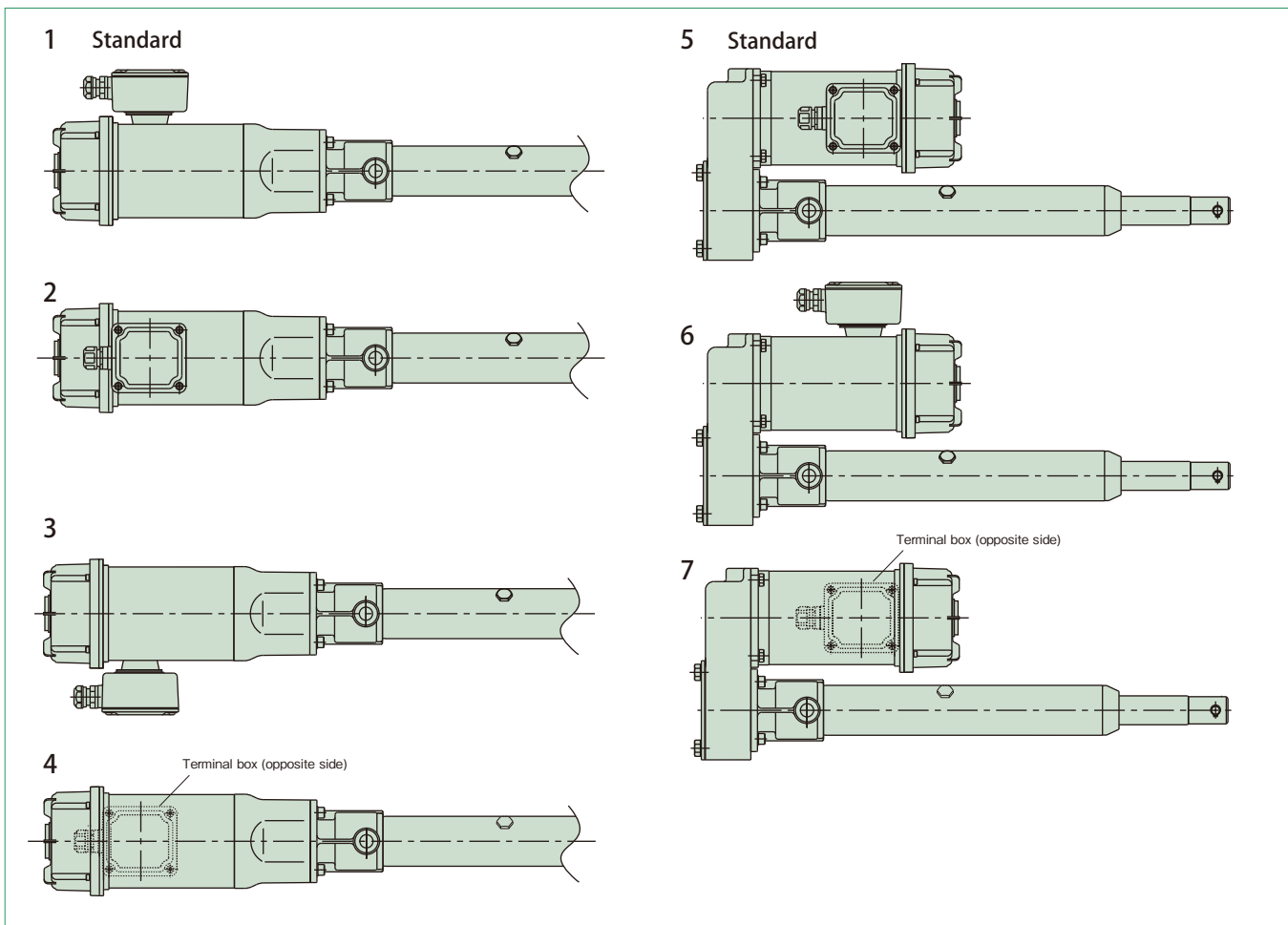



# WARNING

## ■ Cautions for selecting

- Anti-rod rotation is required because a rotating force is exerted on the rod with thrust. Rod rotating forces at the rated thrust are described in the model list. When operating with the end unconnected or when installing pulleys to pull rope, use an optional rod anti-rotation specification.
- When the cylinder operating stroke is short, a high speed type cylinder cannot be used because the operating time per one stroke becomes shorter and cannot be controlled. The following table shows the minimum necessary strokes when motor energization time is 0.5s. Refer to this table to determine the speed.

Speed symbol	H	U
Nominal speed mm/s 50/60Hz	100/120	200/240
0.5s operation moving amount mm	50/60	100/120
Predicted maximum coasting amount mm (Reference)	24/33	67/89
Minimum necessary stroke mm	74/93 or more	167/209 or more

## ■ Cautions for installation

- Apply grease to the trunnion pin and the trunnion hole for trunnion mounting.
- Also, apply grease to the connecting pin of the end fitting and the connecting pin for clevis mounting.
- When the main body greatly swings by operation of the cylinder, consider using a sliding bearing or a rolling bearing for the connecting part. Cylinders whose trunnion hole is provided with sliding bearing are available as MTO.
- When the trunnion pin or connecting pin for the clevis or the end fitting is directed in the vertical direction (when the cylinder is laid horizontally), and the main body swings, take countermeasures for wear such as inserting a bearing member into the trunnion hole, the clevis fitting, or the side part of the end fitting.
- All models are totally enclosed structures so that they can be used normally outdoors, however, under adverse conditions exposed to constant water and steam etc., and snow accumulation, although they are an outdoors type, an appropriate cover is required. The power cylinder can generally be used in a range of -15°C to 40°C, although it varies depending on the use conditions. When using at 40°C or higher, always protect with a heat insulating cover, etc. Never use in a flammable atmosphere, otherwise it may cause an explosion and fire. In addition, avoid using it in a location where vibration or shock exceeding 1G is applied. For use in a misty atmosphere, consult with us.
- When using a cylinder of the cabtire cable lead wire specification outdoors, carry out waterproofing treatment sufficiently.

## ■ Cautions for use

- Regulate both ends of the stroke by the limit switch. Select a type of option which allows the limit switch to be mounted on the power cylinder body.
- Use within the stroke range. If the stroke is exceeded, breakage may occur.
- As a high-speed type (U, H speed) of the power cylinder G series has a long coasting distance, the striker may override the limit switch. (The striker for the U-speed power cylinder overrides the limit switch at the rated lifted load.) For this reason, make sure to allow a limit signal to be self-held on the control circuit.
- Megger testing is prohibited for this cylinder. It may break the built-in power module. Remove the brake wiring for the terminal block when conducting megger testing of the external circuits.
- Adjustment of the limit switch for thrust detection of the GC type must not be carried out by the customer. The preset value for thrust detection may greatly change.

## Easy wiring specifications

This is a specification in which limit switches for thrust detection and external adjustment are wired by us before shipment. For details, request a leaflet.



## Power cylinder G series have become easier to use.



To respond to voices of the “power cylinder is troublesome when it comes to wiring!” from customers, [simple wiring specifications] have been added to LPG series. (Option)

The power cylinder can be selected from two of “Automatic detecting type” and “Centralized terminal box type” with the keywords of simple, neat, reduction in wiring man-hours, and safety (automatic detecting type).

### In standard specifications

- ▷ Large number of wires and its complexity require wiring man-hours and cost at the relay box.
- ▷ Equipment may be damaged due to omission of wiring for the external limit switch for thrust detection and stroke adjustment.

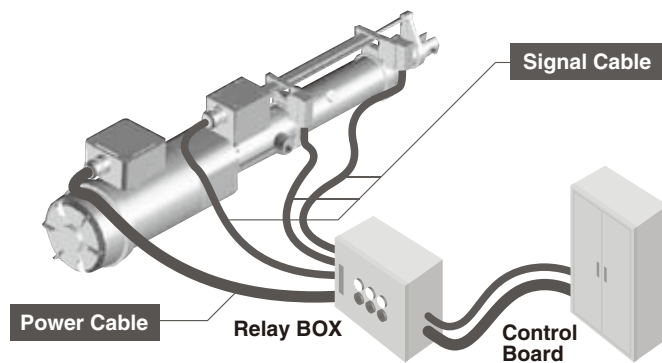

Needs simplicity!

### By adoption of easy wiring specifications

#### Advantages

Slim and simple in appearance

Cost reduction by pre-wired relay boxes

Operates just by connecting the power cable to the terminal box

Prevents damage from excessive torque and stroke caused by incomplete relay box wiring

#### Automatic detecting type

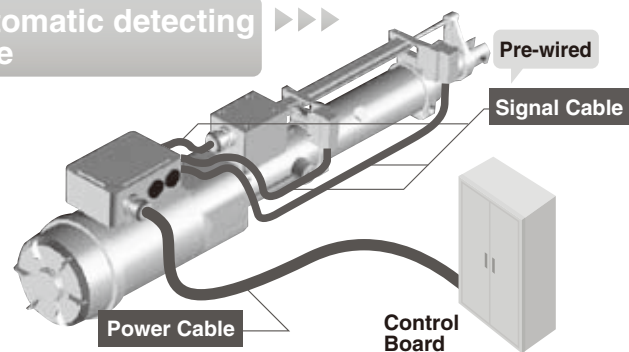

#### Centralized terminal box type

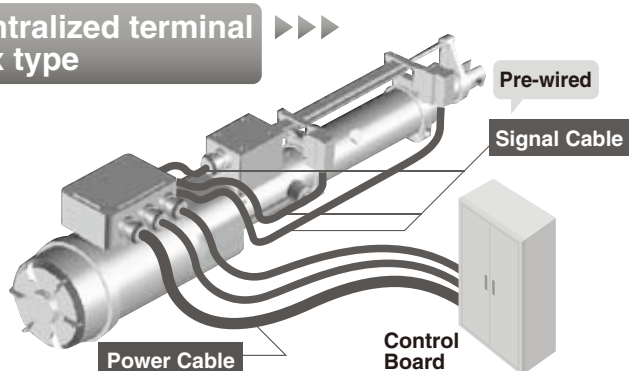

## Power Cylinder

# T series

**Thrust : 2.45kN to 313kN {250kgf to 32000kgf}**

This is a power cylinder of a large thrust type which can be used with AC (alternating current).

Power cylinder T series can be used across a wide range of applications such as steel, injection molding machines, liquid crystal and semiconductor device.

This power cylinder can be used outdoors. (IP55)

- **Two easy-to-select types**

T series have two types which are different in safety mechanisms from each other. The TB type incorporates a wet slip clutch. TC type is equipped with a thrust detecting limit switch.

- **Wide variation**

A wide range of models are available as standard according to application, thrust and speed.

Thrust can be selected in a range from 2.45kN{250kgf} to 313kN{32000kgf}, and speed can be selected in a range from 10mm/s to 120mm/s.

For details, refer to the standard model list.

- **Reliable operation**

All models adopt a highly efficient ball screw, quiet reduction part, and highly reliable brake motor.

All series incorporate a highly reliable safety device which works effectively against overload.

- **Abundance of options**

The stroke adjusting limit switch includes two types of the external type and internal type, and the stroke sensor includes two types of the potentiometer method and rotary encoder method. Control by a sequencer becomes simpler. For a stroke sensor with potentiometer, an option not only indicating stroke but also allowing for control by a meter relay is also available.

- **Quick delivery of special motor (For details, refer to page 120.)**

Heat resistance class F and class H are supported.  
Different voltage specifications (Overseas voltages are supported.)

Inverter specifications

Global specifications (CE-compliant, UL-compliant and CCC-compliant)

Explosion-proof specifications



## Model No. designation

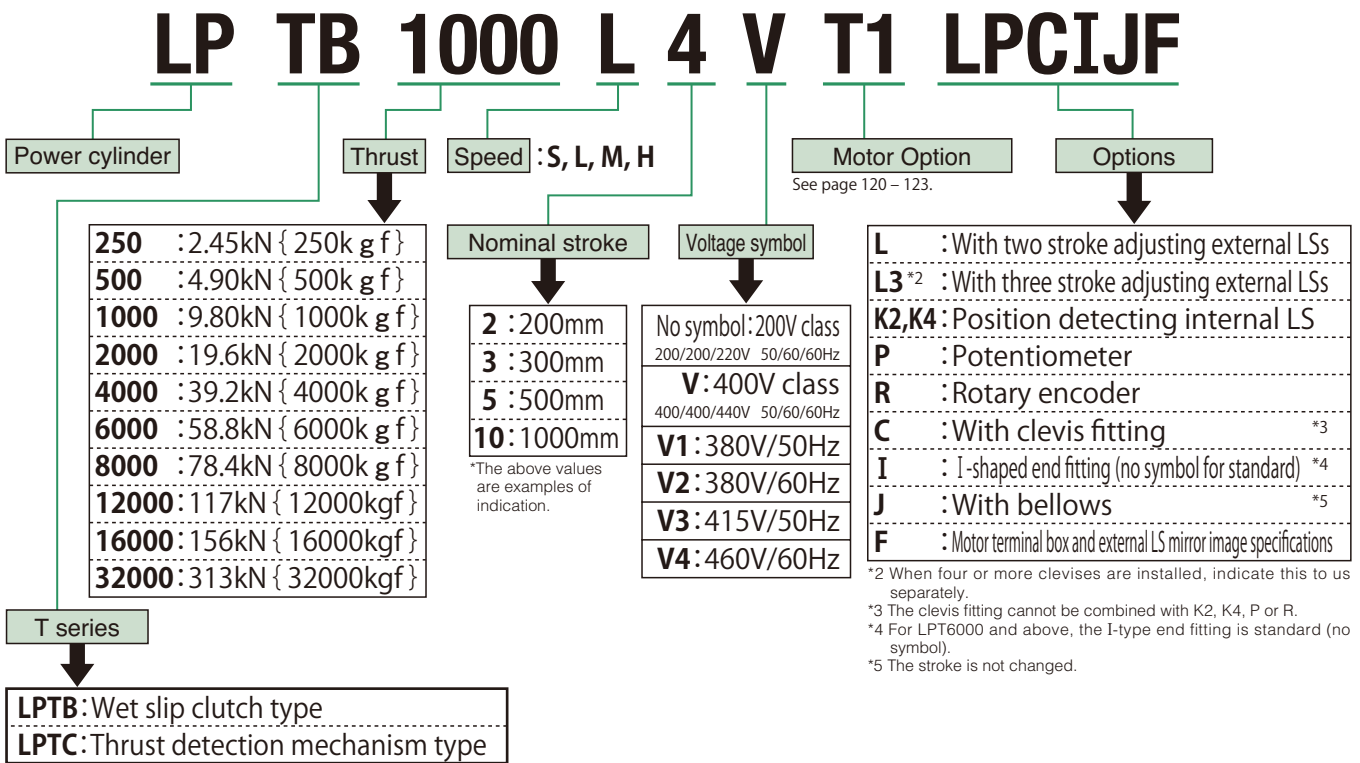

\* The Trunnion fitting is not included in the body model number. Please separately specify a Trunnion model number.  
\* Manual operating handles are also available.

<sup>\*2</sup> When four or more clevises are installed, indicate this to us separately.  
<sup>\*3</sup> The clevis fitting cannot be combined with K2, K4, P or R.  
<sup>\*4</sup> For LPT6000 and above, the I-type end fitting is standard (no symbol).  
<sup>\*5</sup> The stroke is not changed.

## Standard model list

Power cylinder model	Rated thrust		Nominal speed 50/60Hz mm/s	Motor output kW	Rod movement per one turn of manual shaft mm	Rod rotating force		Nominal stroke mm	Brake specifications
	N	{kgf}				N·m	{kgf·m}		
LPTB LPTC	250	2.45k	250	12.5/15	0.1	2.0	2.60	0.27	200, 300, 400 500, 600
L				25/30	0.1	1.0			
M				50/60	0.2	2.0			
H				100/120	0.4	4.0			
LPTB LPTC	500	4.90k	500	12.5/15	0.1	2.0	5.20	0.53	200, 300, 400 500, 600, 800
L				25/30	0.2	1.0			
M				50/60	0.4	2.0			
H				100/120	0.75	3.9			
LPTB LPTC	1000	9.80k (7.84k)	1000 (800)	12.5/15	0.2	2.0	13.8	1.41	200, 300, 400 500, 600, 800 ※ 1000 (Rated thrust is 7.84kN)
L				25/30	0.4	1.0			
M				50/60	0.75	2.0			
H				100/120	1.5	4.0			
LPTB LPTC	2000	19.6k (15.6k) (12.2k)	2000 (1600) (1250)	12.5/15	0.4	2.0	34.7	3.54	200, 300, 400 500, 600, 800 ※ 1000 (Rated thrust is 15.7kN) ※ 1200 (Rated thrust is 12.2kN)
L				25/30	0.75	1.0			
M				50/60	1.5	2.0			
H				75/90	2.2	3.0			
LPTB LPTC	4000	39.2k (33.3k)	4000 (3400)	9/11	0.75	1.4	83.2	8.49	200, 300, 400 500, 600, 800 1000, 1200 ※ 1500 (Rated thrust is 33.3kN)
L				25/30	1.5	1.0			
M				35/42	2.2	1.4			
H				60/72	3.7	2.4			
LPTB LPTC	6000	58.8k	6000	6.3/7.6	0.75	1.0	124	12.7	500 1000 1500
L				17.5/21	1.5	0.7			
M				25/30	2.2	1.0			
H				42/50	3.7	1.7			
LPTB LPTC	8000	78.4k	8000	10/12	1.5	1.2	222	22.6	500 1000 1500
L				20/24	2.2	0.8			
M				30/36	3.7	1.2			
H				43/52	5.5	1.7			
LPTB LPTC	12000	117k	12000	10/12	2.2	1.2	333	34.0	500 1000 1500 2000
L				18/22	3.7	2.2			
M				30/36	5.5	1.2			
H									
LPTB LPTC	16000	156k	16000	14.5/17.5	3.7	2.9	666	67.9	500 1000 1500 2000
L				20/24	5.5	3.2			
M				31/37	7.5	3.7			
H									
LPTB LPTC	32000	313k	32000	10/12	5.5	0.4	1330	136	500 1000 1500 2000
L				15/18	7.5	0.6			
M				20/24	11	0.8			
H									

● DC brake  
● Brake external wiring is available

Note) The numerical value in parentheses on rated thrust is for the long stroke type.

1) The rated thrust is limited for the stroke marked with an\*.  
2) The speeds indicate a value at the motor synchronized rotating speed.

## Motor specifications

Model	Totally enclosed self cooling type with brake
Output	Refer to Standard model dimensions list
Number of poles	4 poles
Voltage	3φ 200V/200V/220V
Frequency	50Hz/60Hz/60Hz
Heat resistance class	E (B for 1.5kW or less)
Time rating	S2 30min.
Protection method	Totally enclosed outdoor type (IP55)

1) 400/440V, different voltage specifications other than the above voltages are also available.  
 2) For motor current value and brake current value, refer to page 115.

## Painting color

TSUBAKI olive gray (Munsell 5GY6/0.5 or approximate color)

## Standard use environment

Environment Model	Ambient temperature	Relative humidity	Impact resistance value	Installation altitude	Atmosphere
Outdoor type	-15°C ~ 40°C	85% or less (no dew condensation)	1G or less	1000m or lower above sea level	Normally outdoors

- 1) Cylinders with bellows are recommended in an excessively dusty location.
- 2) Special painting is available for locations exposed to sea breezes and salt. Consult us.
- 3) All models are totally enclosed structures so that they can be used normally outdoors, however, under adverse conditions exposed to constant water and steam etc., and snow accumulation, although they are an outdoors type, an appropriate cover is required. When using at 40°C or higher, always protect with a heat insulating cover, etc. Never use in a flammable atmosphere, otherwise it may cause an explosion and fire. In addition, avoid using it in a location where vibration or shock exceeding 1G is applied.
- 4) For use in a misty atmosphere, contact us.

## Structure

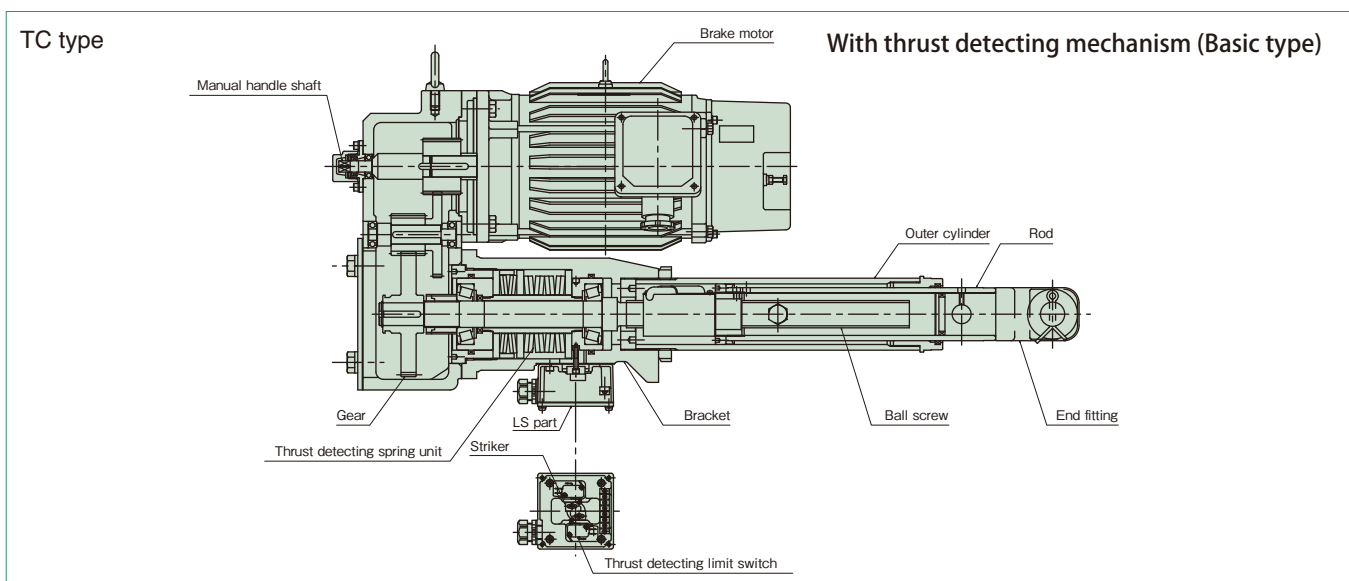
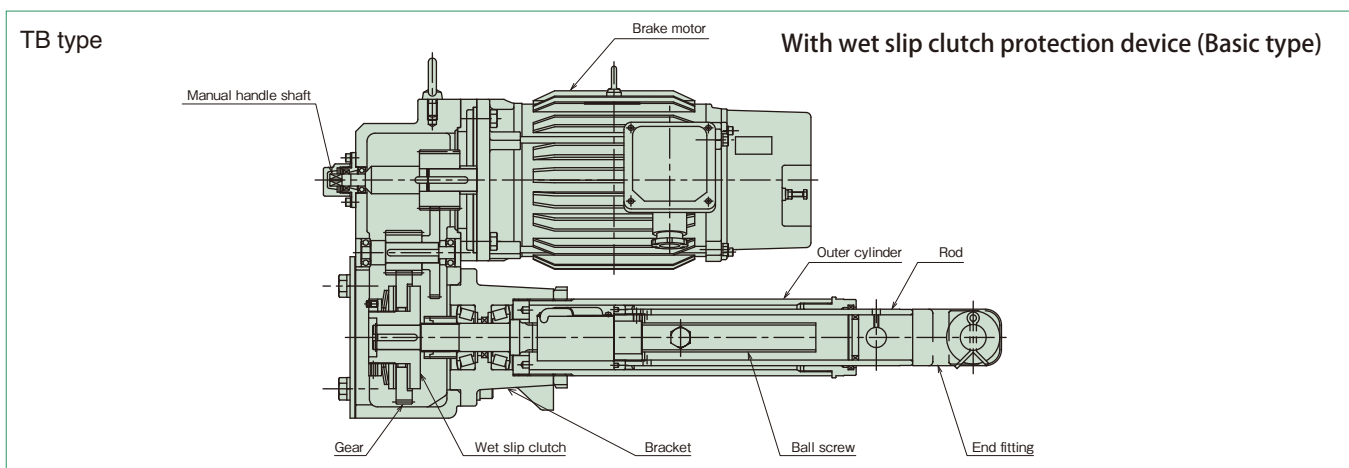

\* The structure slightly varies depending on the model.

**Brake motor** — This motor adopts a deenergization operation type (spring close type), and the brake is applied while the cylinder stops. This brake action holds load while the power cylinder stops and reduces coasting during stoppage, and serves the purpose of increasing stop accuracy. All of the brake motors adopt outdoor types.

**Reduction part** — The reduction part adopts a combination of a helical gear on the high speed side and a spur gear on the low speed side. The lubrication method is grease bath type, and has a quiet operating specification. Furthermore, a manual handle shaft is provided, and the structure of the speed reducer facilitates operation at power failure and adjustment for installation. As options, various position detecting devices can be installed.

**Actuation part** — The actuation part is provided with a ball screw and nut which converts a rotating force into linear motion. Further, external limit switches for stroke adjustment can be mounted. A high precision ball screw and nut have advantages such as high transmission efficiency, less wear, long life and easy lubrication. The external limit switches for stroke adjustment are structured to freely adjust the stroke and endure outdoor use. The bellows are excellent in weatherproofing, and the stroke does not change even if the bellows are mounted. The seal for the rod also endures outdoor use.



## Classification of usage for LPTB and LPTC types

Both types of the power cylinders have the same basic functions (thrust, speed, stroke), however, each has its feature as regards the mechanism. Read the following to select the optimum type.

### TB type

#### ● Wet slip clutch type (simple type)

[Wet slip clutch]

The screw shaft end of the reduction part incorporates a slip clutch which operates stably in grease as a safety device.

Adoption of special lining exerts a protective function even at the time of overload or stroke overextension.

\* When overload is electrically detected, use in combination with our shock relay is recommended.

### TC type

#### ● Thrust detecting mechanism type

This type exerts its effect in the following cases.

- ① When performing press (pull) stop
- ② When requiring an electric signal at the time of overload
- ③ When an overload is possibly applied from the load side during stop

When an overload is impulsively applied, the incorporated spring absorbs the impact load.

[Thrust detecting mechanism]

This is a thrust detecting mechanism which combines two types of pre-loaded disc springs whose spring constants are different from each other and limit switches. The combined effect of these disc springs also allows for press and stop of the high speed type. (There is only one type for the 6000 type and larger.)

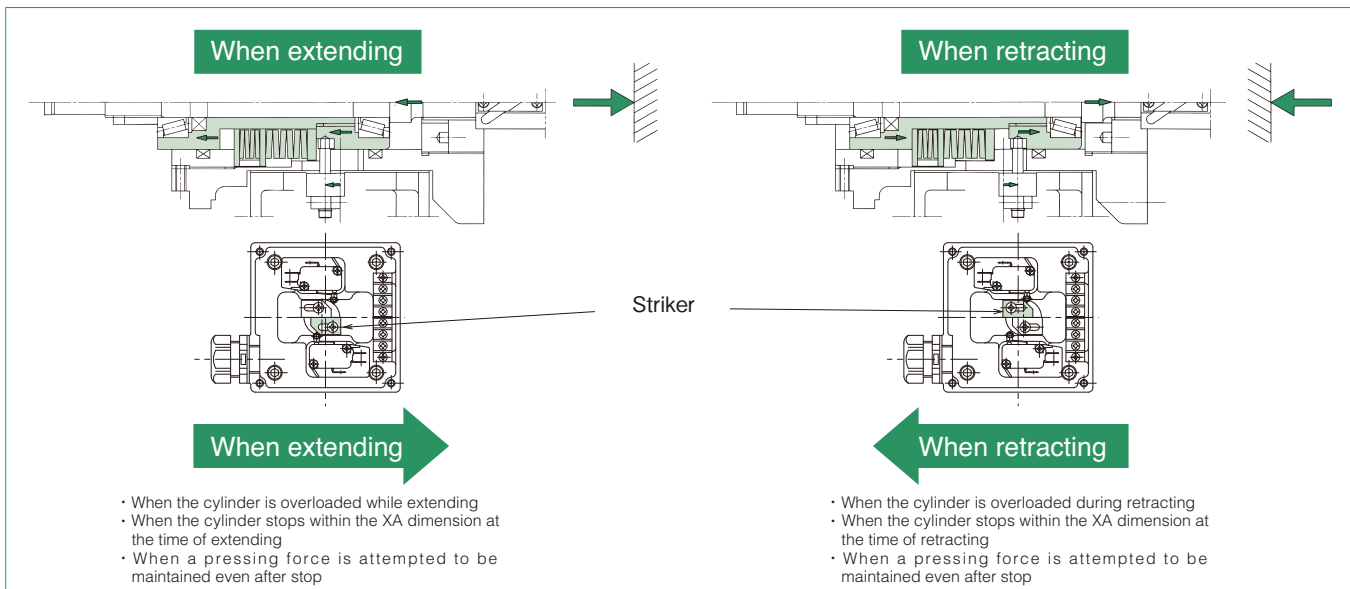

### Preset thrust for safety device

For both of the TB type and TC type, the thrust for the safety device has been set to approximately 150% to 200% of the rated thrust. The safety device does not work at the start for opening/closing of the damper or the hopper gate, normal reverse, inclination and elevation, however, when a load inertia is large due to horizontal movement of carriage, the safety device may work to impair smooth operation at the start. For the allowable mass  $M$  of each model, see Table 4 on page 92.

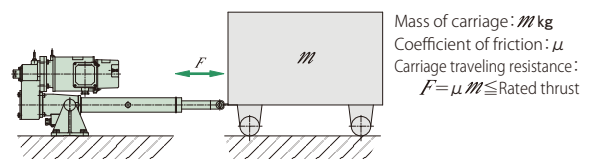

## Cautions for use

#### ● When pressing (pulling) and stopping at high frequency

When using the power cylinder at a frequency of ten or more times a day, refer to the total stop times for every model in the following table.

Type	LPTC250~LPTC4000			LPTC6000~LPTC32000		
	S,L	M	H	S,L	M	H
Reference total stop times ( $\times 10^4$ times)	30	10	5	10	3	1

Note) When the power cylinder is used for press (pull) contact stopping, external wiring is recommended for the wire connection of the brake.

Note) When the power cylinder is used exceeding the values on the above table, it is recommended to stop with the stroke adjusting LS.

Note) When the power cylinder is used with press (pull) stop, strength of the mating equipment shall be 250% or more of the rated thrust.

#### ● When multiple operation or stroke position control is performed

##### ① When installing rotary encoder or potentiometer

For the TC type, a spring mechanism is built in the operating part. The spring slightly deflects at press (pull) and stop, or when overload occurs, the signal amount deviates by the deflection. For the TB type, even if the safety device is tripped, signal amount does not deviate. However, the TC type can be used at normal stroke operation.

##### ② When there is a problem with movement of the rod even if overload is applied from load side during stop

For the TC type, a spring mechanism is built in the operating part, therefore, when a large load is applied from the load side, the spring deflects and the rod moves by the deflection.

When the load is eliminated, the rod returns to the original position.

# Selection 1

## Conditions of use required for selection

- |   |  |
|---|--|
| <ol style="list-style-type: none"> <li>1. Machine to be used and application</li> <li>2. Thrust or load N { kgf }</li> <li>3. Stroke mm</li> <li>4. Speed mm/s</li> <li>5. Frequency of operation, cycles/min.</li> </ol> | <ol style="list-style-type: none"> <li>6. Hours of operation and annual number of operating days</li> <li>7. Type of load of machine used</li> <li>8. Environment of use</li> <li>9. Power voltage, frequency</li> </ol> |
|---|--|

## Selection procedures

### Determination of model STEP 1

Determine the type (TB or TC) according to the use environment and method of operation.

### Determination of model No. STEP 2

1. Obtain annual traveling distance from the stroke, frequency of operation and hours of operation.

$$\text{Annual traveling distance km} = \text{Actual stroke m} \times \text{Frequency of use/day} \times \text{number of operating days} \times 10^{-3}$$

2. Obtain the operation factor from the characteristics of load and the machine used, referring to Table 1.

3. Multiply thrust or load by operation factor to obtain a corrected thrust.
4. Determine the frame No. from the "Expected Traveling Distance" shown below on this page according to the corrected thrust and annual traveling distance, and select an applicable model No. from the standard model list (page 87) based on the stroke, speed, power supply voltage and frequency.

### Characteristics check STEP 3

1. Use the power cylinder at a frequency of operation below the allowable frequency of operation (Table 2).
2. Check the load time ratio.
3. Positioning accuracy varies depending on the stopping method. Refer to the stopping method (page 91).

**Table 1 Operation factor**

Characteristics of load	Example of machine used	Operation factor
Smooth operation without impact Small inertia	Damper, opening/closing of valve, conveyor changeover device	1.0~1.3
Operation with light impact Intermediate inertia	Opening/closing of hopper gate, various transfer equipment, various lifter elevation	1.3~1.5
Operation with large impact and vibration Large inertia	Heavy object conveyance by carriage, buffer for belt conveyor, inversion opening/closing device for large lid	1.5~3.0

Note) The above operation factor table shows general guidelines. Therefore, make a determination in consideration of operating conditions.

**Table 2 Allowable frequency of operation**

Type	LPTB·LPTC	LPTB·LPTC	LPTB·LPTC	LPTB·LPTC	LPTB·LPTC	LPTB·LPTC	LPTB·LPTC	LPTB·LPTC	LPTB·LPTC	LPTB·LPTC
Power cylinder model	250S 250L 500S	250M 500L 1000S	250H 500M 1000L 2000S	500H 1000M 2000L 4000S 6000S	1000H 2000M 4000L 6000L 8000S	2000H 4000M 6000M 8000L 12000L	4000H 6000H 8000M 12000M 16000L	8000H 12000H 16000M 32000L	16000H 32000M	32000H
Number of starting times (Number of times/min)	5	5	5	4	4	4	4	3	3	2
Load time ratio(%ED)	25%ED									

Note) The above frequencies of operation are values determined by heat generation of the motor. They are not values taking life of the cylinder body into consideration.

Allowable frequency of operation for the power cylinder T series is within a range which satisfies the number of starting times and load time ratio in the above table. The load time ratio is expressed by the following equation.

$$\text{Load time ratio (\%ED)} = \frac{\text{Operation time of one cycle}}{(\text{Operation time of one cycle} + \text{dwell time})} \times 100\%$$

## Guide for life

Use the number of operation times of the brake and the traveling distance of the cylinder (nut) as a guide for product life of the power cylinder T series to select the cylinder (nut).

### 1. Number of operation times of brake

Expected life 2 million times

### 2. Traveling distance of cylinder (nut)

The life of a ball screw is determined by flaking of the rolling surface caused by its fatigue. Check the rough life with this chart of expected traveling distance. However, in the case of great impact or in the case where lubrication or maintenance is not performed properly, the expected traveling distance becomes substantially short.

$$\text{Expected traveling distance (km)} = \text{actual load stroke (m)} \times \text{frequency of use (times/day)} \times \text{number of operating days} \times 10^{-3} \times \text{expected number of years}$$

The chart on the right-hand side is based on L10 life. L10 life expresses in traveling distance a life that can be reached by 90% or more of all ball screws. If you select a power cylinder based on the life, select model No. from this chart. If the load greatly fluctuates in the middle of stroke, calculate the equivalent load ( $P_M$ ) by the following equation.

$$P_M = \frac{P_{MIN} + 2 \times P_{MAX}}{3}$$

$P_M$  : Equivalent load N { kgf }  
 $P_{MIN}$  : Minimum load N { kgf }  
 $P_{MAX}$  : Maximum load N { kgf }

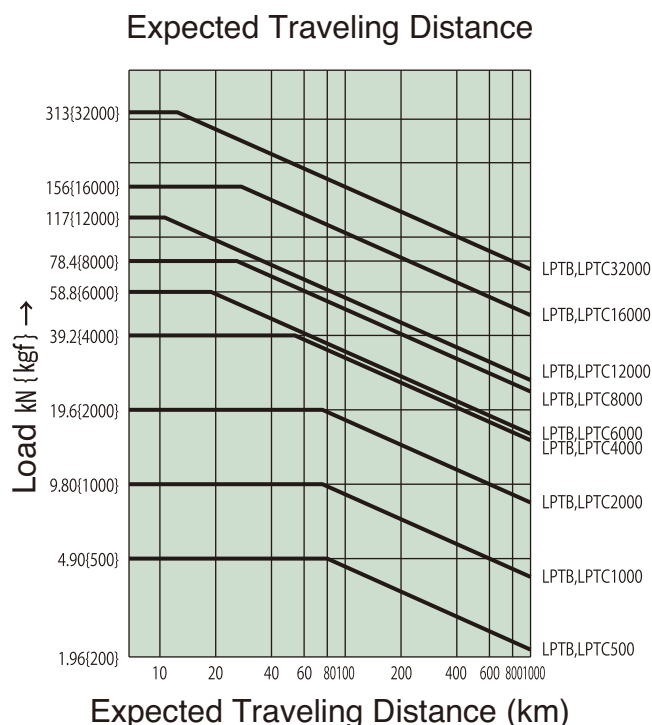
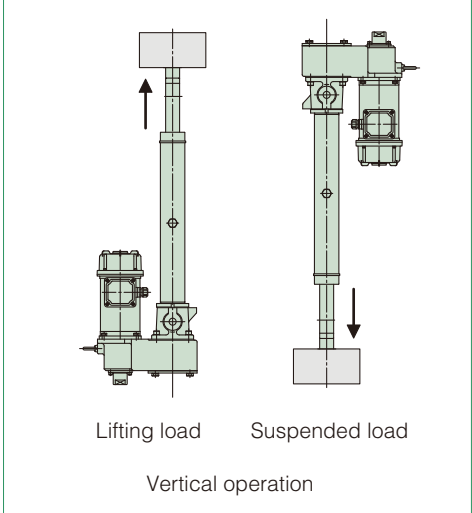

Table 3 Coasting distance and stop accuracy (Reference value)

Unit: mm

Usage	Brake internal connection				Brake external connection				
	Lifting load		Suspended load		Lifting load		Suspended load		
	Coasting distance	Stop accuracy	Coasting distance	Stop accuracy	Coasting distance	Stop accuracy	Coasting distance	Stop accuracy	
Model	S	2.2	±0.4	3.0	±0.6	1.9	±0.3	2.7	±0.5
	L	4.3	±0.8	8.5	±2.1	3.7	±0.6	7.8	±1.9
	M	6.9	±1.4	12.4	±3.2	6.0	±1.1	11.4	±2.9
LPTC	H	13.7	±2.7	27.3	±7.3	12.5	±2.4	26.1	±6.9
	S	2.1	±0.4	3.7	±0.9	1.8	±0.3	3.3	±0.8
	L	3.6	±0.7	6.1	±1.6	3.1	±0.6	5.6	±1.4
LPTC	M	6.5	±1.3	11.4	±2.9	5.9	±1.2	10.8	±2.7
	H	12.7	±2.7	22.3	±5.9	10.2	±2.0	19.6	±5.2
	S	1.7	±0.4	2.8	±0.7	1.5	±0.3	2.5	±0.6
LPTC	L	3.2	±0.7	5.4	±1.4	2.9	±0.6	5.1	±1.2
	M	6.3	±1.4	10.2	±2.6	5.0	±1.0	8.8	±2.2
	H	15.6	±3.3	27.6	±7.7	10.4	±2.0	22.1	±6.3
LPTC	S	1.7	±0.4	2.7	±0.7	1.5	±0.3	2.5	±0.6
	L	3.2	±0.7	5.0	±1.3	2.5	±0.5	4.2	±1.0
	M	7.7	±1.7	12.7	±3.4	5.2	±1.0	10.0	±2.7
LPTC	H	13.3	±2.9	22.8	±6.4	8.0	±1.6	17.1	±4.9
	S	1.2	±0.3	1.6	±0.4	0.9	±0.2	1.3	±0.3
	L	3.8	±0.8	5.9	±1.5	2.5	±0.5	4.5	±1.1
LPTC	M	6.4	±1.4	9.9	±2.6	3.8	±0.8	7.2	±1.9
	H	10.9	±2.4	16.9	±4.4	6.6	±1.3	12.3	±3.2
	S	0.6	±0.2	0.8	±0.2	0.5	±0.1	0.6	±0.1
LPTC	L	2.7	±0.6	4.4	±1.2	1.8	±0.4	3.4	±0.9
	M	4.5	±1.0	7.4	±2.0	2.7	±0.5	5.5	±1.5
	H	7.6	±1.7	12.2	±3.2	4.6	±0.9	9.0	±2.4
LPTC	S	1.9	±0.4	2.9	±0.7	1.3	±0.2	2.2	±0.5
	L	3.6	±0.8	5.8	±1.6	2.2	±0.4	4.3	±1.1
	M	5.6	±1.2	8.4	±2.1	3.4	±0.7	6.1	±1.5
LPTC	H	—	—	—	—	5.4	±1.0	8.7	±2.0
	L	2.1	±0.5	3.0	±0.8	1.3	±0.2	2.2	±0.5
	M	3.5	±0.8	5.1	±1.3	2.1	±0.4	3.6	±0.9
LPTC	H	—	—	—	—	3.6	±0.7	5.9	±1.4
	L	2.8	±0.6	4.0	±1.0	1.7	±0.3	2.8	±0.7
	M	—	—	—	—	2.6	±0.5	4.0	±0.9
LPTC	H	—	—	—	—	3.9	±0.7	8.6	±2.4
	L	—	—	—	—	1.3	±0.3	2.0	±0.4
	M	—	—	—	—	2.0	±0.4	4.2	±1.1
LPTC	H	—	—	—	—	2.7	±0.5	4.4	±1.0

Fig. 1 Type of load



Note) Anti-rod rotation is required for actual operation.

**Brake holding force**

Load holding force while the power cylinder stops is generated more than the rated thrust, therefore, it can be used for holding load of the rated thrust. This holding force is generated by the braking operation of the brake motor. The brake is of a spring braking type that always performs braking operation by spring force during stoppage, and brake torque has a holding force of 150% or more of the motor rated torque.

**Stoppage**

This method operates and stops the brake by the limit switch or operation of the stop button, and allows for positioning on multi-stages such as the upper limit, lower limit and middle of the stroke. Coasting distance and stop accuracy vary depending on operating speed and load. When accurate positioning is required, low operation speed or brake individual turnoff is recommended. Take coasting distance into consideration to set the limit switch and the output stop signal. Reference values are shown in Table 3.

Coasting distance: This indicates a distance from the time when the limit switch or the stop button is operated until the cylinder stops. This coasting distance varies depending on how the load is applied and the operation circuit.  
 Stop accuracy: This indicates variation of the stop position when stop is repeated.

- \* When selecting the H speed, refer to the cautions for selecting on page 118.
- \* Select a power cylinder of a sufficient thrust, allowing for a safety rate so that the loads used (static and dynamic) do not exceed the rated thrust.

**Example of selection**

1. Operation method : Opening degree adjustment type damper open/close (Stop at middle two points, press and stop at extend limit and retract limit)
2. Required thrust : 12.7kN {1300kgf}
3. Stroke : 600mm
4. Speed : 600mm/s for approximately 20 seconds
5. Frequency of operation : One reciprocation/10 minutes (6 reciprocations/hour)
6. Operating time : 10 hours/day, 250 days operation/year, durable years approximately 5 years
7. Characteristics of load : Operation with light impact, loaded when extend and retract
8. Use environment : Outdoor installation, much dust, temperature 0°C~35°C
9. Power source : 220V 60Hz

<Determination of type>: With press and stop, internal stop → Select TC type

<Determination of model No.>: 1. Operation factor : 1.3

2. Corrected thrust : 12.7kN {1300kgf} × 1.3 = 16.5kN {1680kgf}

3. Model No. : LPTC 2000L6  $\frac{K2}{J}$   
 Stop at two middle points ———— With bellows (much dust)

<Characteristics check>: 1. Number of starting times

● Number of starting : 2 times/10min < 4 times/min

● Load time ratio :  $\frac{600}{30} \times 2 \div 10 \times 60 \times 100 = 6.7\% < 25\%$

2. Number of total press (pull) stop times : 2 times/1 reciprocation, durable years: 5 years (250 days/year)  
 $2 \times 6 \times 10 \times 250 \times 5 = 15 \times 10^4 \text{ times} < 30 \times 10^4 \text{ times}$

<Life check>: 1. Annual traveling distance :  $0.6 \times 2 \times 6 \text{ times/hour} \times 10 \text{ hours/day} \times 250 \text{ days/year} \times 10^{-3} = 18 \text{ km}$

2. Expected traveling life :  $18 \text{ km} \times 5 \text{ years} = 90 \text{ km}$

3. Equivalent load :  $P_M = \frac{16.5 + 16.5 \times 2}{3} = 16.5 \text{ kN} \{1680 \text{ kgf}\}$

This calculated value satisfies the expected traveling life of LPTC 2000 according to the load-life diagram on page 90.

## Selection 2

Table 4 Allowable mass in consideration of inertia at time of horizontal drive

Unit: kg

Power cylinder model	LPTB : 250 LPTC : 250			LPTB : 500 LPTC : 500			LPTB : 1000 LPTC : 1000			LPTB : 2000 LPTC : 2000			LPTB : 4000 LPTC : 4000		
	L	M	H	L	M	H	L	M	H	L	M	H	L	M	H
Allowable mass $\mathcal{M}$	4300	1500	850	5500	2650	950	10000	3200	2200	12300	8400	7100	31800	26000	16800

Power cylinder model	LPTB : 6000 LPTC : 6000			LPTB : 8000 LPTC : 8000			LPTB : 12000 LPTC : 12000			LPTB : 16000 LPTC : 16000			LPTB : 32000 LPTC : 32000		
	L	M	H	L	M	H	L	M	H	L	M	H	L	M	H
Allowable mass $\mathcal{M}$	73000	60000	39000	106000	69000	86000	271000	158000	200000	274000	344000	189000	1368000	761000	860000

Note) There is no problem with low speed S.

## Selection 3

### Multiple operation method

As shown in Fig. 2, transfer or elevation can be carried out by sharing load on some power cylinders.

This is because there is less speed fluctuation due to variation in load. For selection, pay attention to the items at the right.

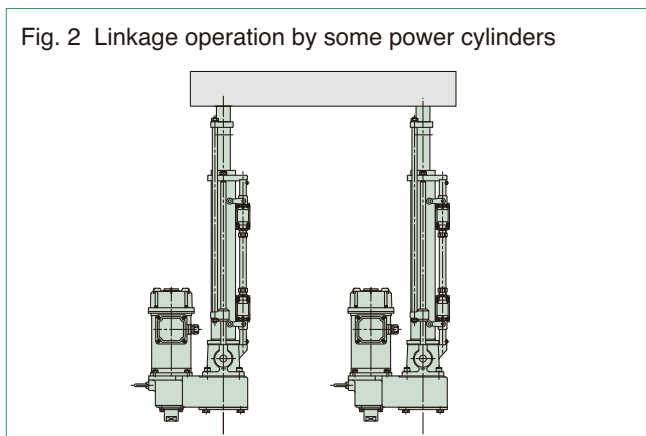

Fig. 2 Linkage operation by some power cylinders

### Control method

To start, turn on the power for all of the cylinders, and stop them with the limit switches installed on each power cylinder. When all of the cylinders are controlled with one limit switch, stroke error is accumulated, therefore, avoid controlling with one limit switch.

For an example of the control circuit, refer to example of the multiple circuit (page 116).

### Multiple accuracy

Variation in speed of each power cylinder during operation is generated due to variation in load, and is generally approximately 5%. For variation at stop, refer to the stop accuracy in Table 4. When synchronizing power cylinders, use the multi-series. (Page 124)

$$\text{Thrust per one cylinder} = \frac{\text{Required thrust N (kgf)}}{\text{Number of power cylinders to be used} \times \text{Multiple factor}}$$

Table 5 Multiple factor

Number of power cylinders used	2 cylinders	3 cylinders	4 cylinders	5 cylinders	6 cylinders
Multiple factor	0.8	0.7	0.6	0.55	0.5

### Cautions for layout

When the load is in the right angle direction (lateral load) or load of which direction is biased (biased load) is applied on the rod, take the following countermeasures.

① Lateral load Install guide roller etc., on the rod part. (Fig. 3)

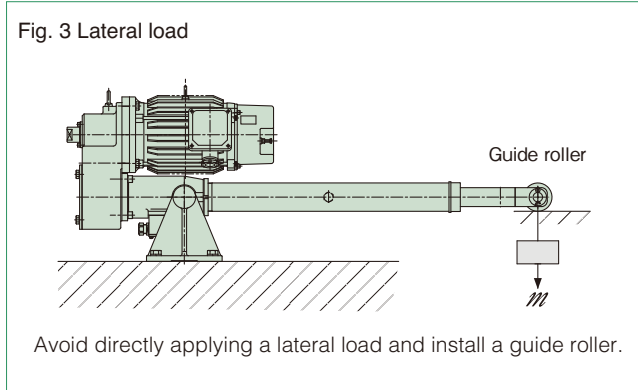

Fig. 3 Lateral load

Avoid directly applying a lateral load and install a guide roller.

② Biased load Install balance weight etc. (Fig. 4)

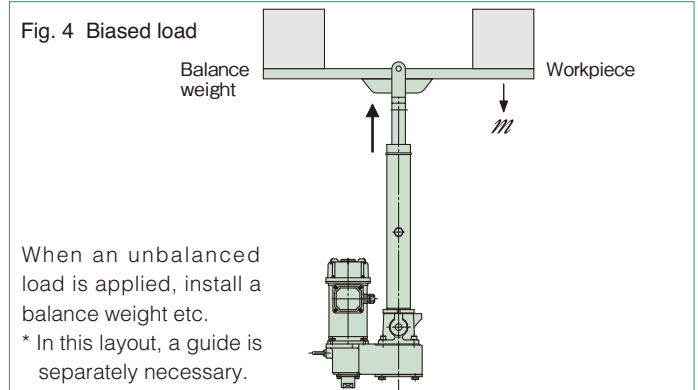

Fig. 4 Biased load

When an unbalanced load is applied, install a balance weight etc.  
\* In this layout, a guide is separately necessary.

③ Anti-rod rotation --- A rotating force is generated on the rod with thrust (page 87), therefore, prevent rotation on the equipment side.

④ Vertical installation of stroke adjusting external LS (stroke 300mm or less) --- The connector portion of the external LS appears below the trunnion mounting base surface. (Fig. 5)

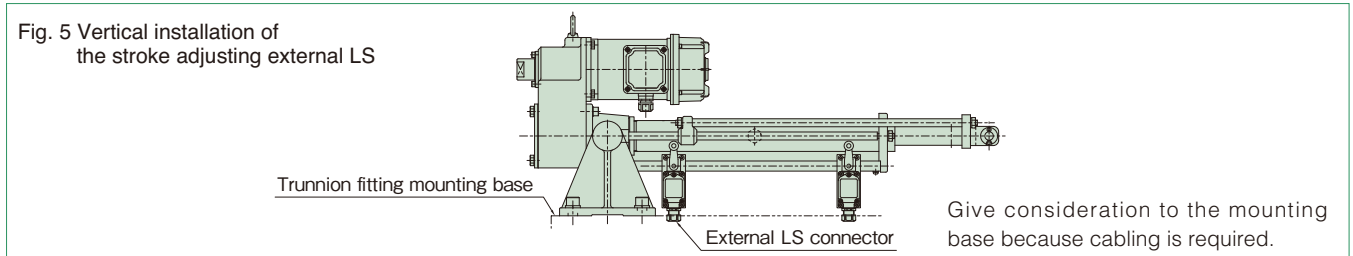
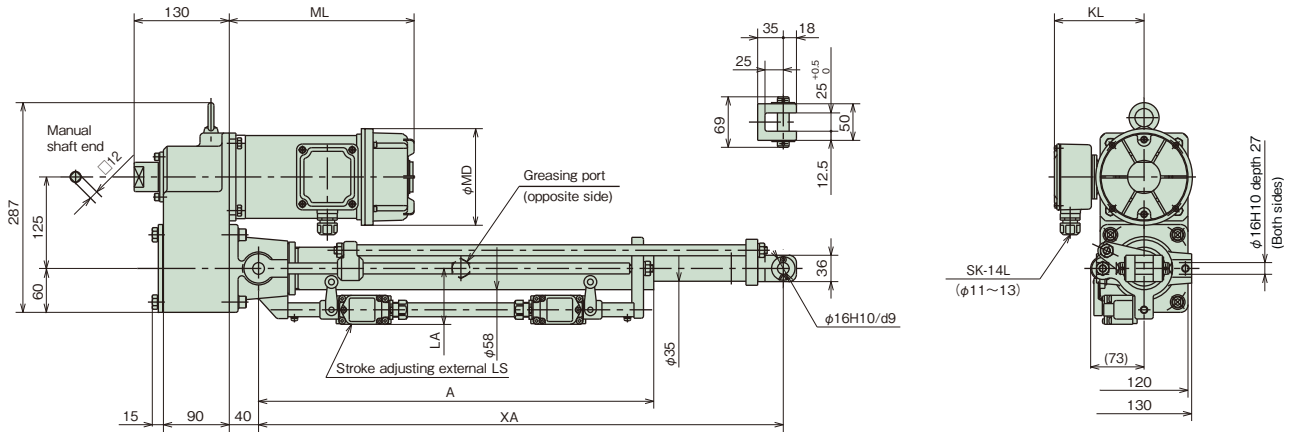

Fig. 5 Vertical installation of the stroke adjusting external LS

Give consideration to the mounting base because cabling is required.

# Dimensions Table T Series 250

## LPTB250



Unit: mm

Model	Nominal speed mm/s 50/60Hz	Motor kW	MD	ML	KL
LPTB250S	12.5/15	0.1	132	296	125
LPTB250L	25/30			231	
LPTB250M	50/60	231			
LPTB250H	100/120	253			

Approximate mass of main body

Unit: kg

Nominal stroke Model	200	300	400	500	600
LPTB250S	35	36	37	38	39
LPTB250L	32	33	34	35	36
LPTB250M	32	33	34	35	36
LPTB250H	34	35	36	37	38

1. This diagram shows a power cylinder with an external limit switch for stroke adjustment.
2. If the stroke is 300mm or less and a limit switch for stroke adjustment is equipped, the limit switch is vertically mounted. Note that the LA dimension becomes larger. (See ④ in Cautions for layout on page 92.)
3. Mechanical stroke has a margin of approximately 10mm on both sides for the nominal stroke.
4. For the cylinder with bellows, the stroke will also not change.
5. For connector part dimensions of the motor terminal box, refer to page 115.

Unit: mm

Nominal stroke	Thrust		A	XA		LA
	kN	{ kgf }		MIN	MAX	
200	2.45	250	340	435	635	161
300			440	545	845	
400			540	655	1055	
500			640	765	1265	76.5
600			740	870	1470	

## Options

### ■ Bellows ( - J )

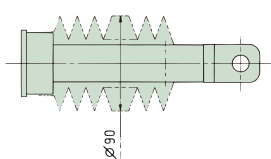

### ■ I-type end fitting ( - I ) ■ Clevis fitting ( - C )

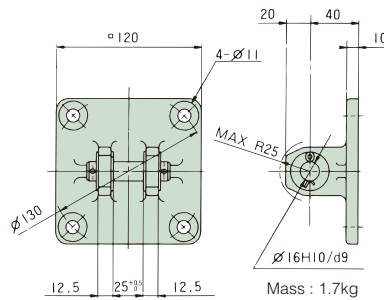
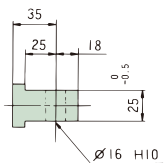

### ■ Trunnion fitting (LPTB500-T)

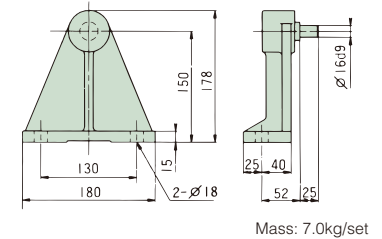

Note) Shipped as attached to the main body. The XA dimensions are the same as the standard U-type end fitting.

Note) Shipped attached to the main body. If it needs to be shipped individually, consult us.

Note) Apply grease to the trunnion pin and trunnion hole before mounting.

\* Dimensions with no tolerance described have general tolerance, and their sizes become larger by approximately 2 to 5mm from the described dimensions. When designing the machine, take the margin into consideration.

# Dimensions Table T Series 250

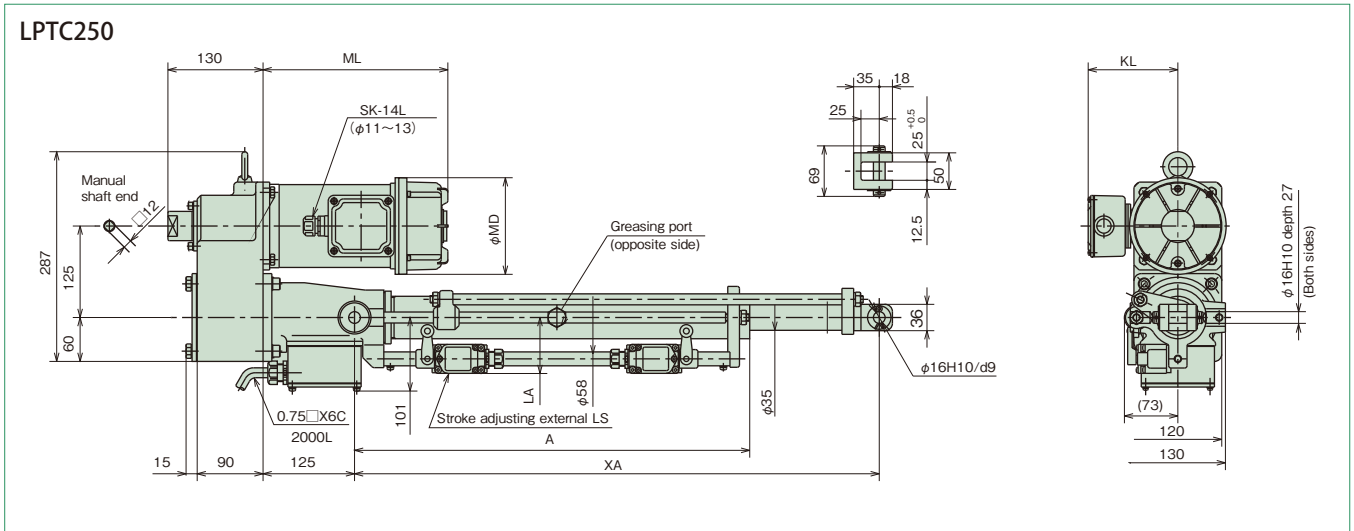

Unit: mm

Model	Nominal speed mm/s 50/60Hz	Motor kW	MD	ML	KL
LPTC250S	12.5/15	0.1	132	296	125
LPTC250L	25/30			231	
LPTC250M	50/60	0.2		253	
LPTC250H	100/120	0.4			

Unit: mm

Nominal stroke	Thrust		A	XA		LA
	kN	{ kgf }		MIN	MAX	
200	2.45	250	340	435	635	161
300			440	545	845	
400			540	655	1055	
500			640	765	1265	76.5
600			740	870	1470	

Approximate mass of main body Unit: kg

Nominal stroke Model	200	300	400	500	600
LPTC250S	39	40	41	42	43
LPTC250L	36	37	38	39	40
LPTC250M	36	37	38	39	40
LPTC250H	38	39	40	41	42

1. This diagram shows a power cylinder with an external limit switch for stroke adjustment.
2. If the stroke is 300mm or less and a limit switch for stroke adjustment is equipped, the limit switch is vertically mounted. Note that the LA dimension becomes larger. (See ④ in Cautions for layout on page 92.)
3. Mechanical stroke has a margin of approximately 10mm on both sides for the nominal stroke.
4. For the cylinder with bellows, the stroke will also not change.
5. Use TC type model in brake individual turnover.
6. For connector part dimensions of the motor terminal box, refer to page 115.

## Options

### ■ Bellows ( - J )

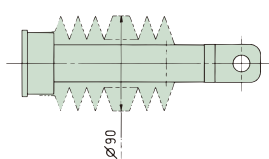

### ■ I-type end fitting ( - I )

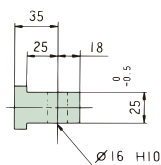

Note) Shipped as attached to the main body.  
The XA dimensions are the same as the standard U-type end fitting.

### ■ Clevis fitting ( - C )

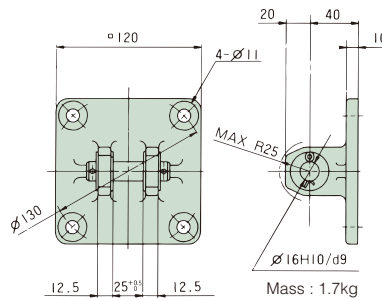

Note) Shipped attached to the main body.  
If it needs to be shipped individually, consult us.

### ■ Trunnion fitting (LPTB500-T)

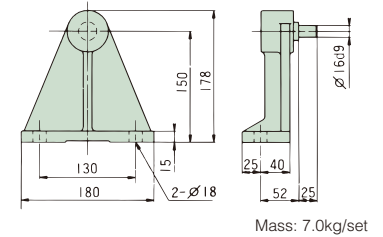

Note) Apply grease to the trunnion pin and trunnion hole before mounting.

\* Dimensions with no tolerance described have general tolerance, and their sizes become larger by approximately 2 to 5mm from the described dimensions. When designing the machine, take the margin into consideration.



# Dimensions Table T Series 500

## LPTB500

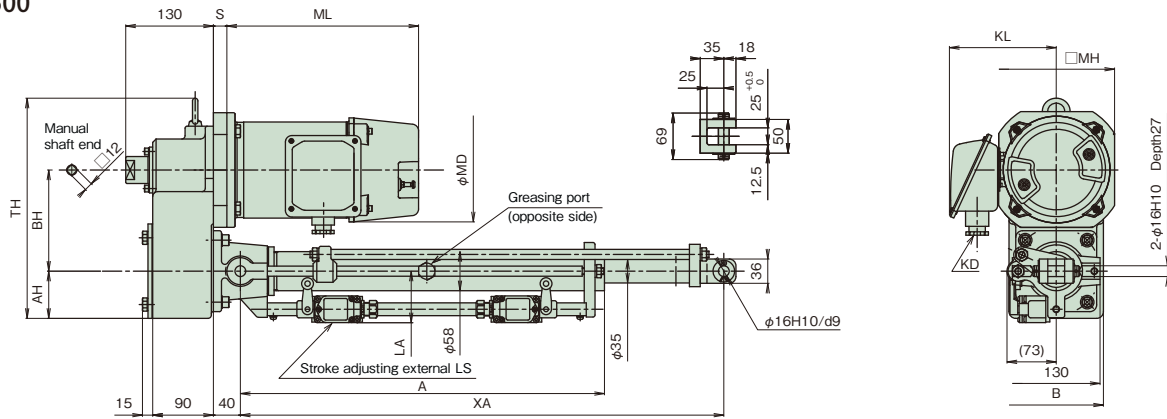

Unit: mm

Model	Nominal speed mm/s 50/60Hz	Motor kW	MD	ML	KL	KD	MH	AH	BH	TH	S	B	C	E	F	G	H	J	K	L
LPTB500S	12.5/15	0.1	132	231	125	SK-14L	120	60	125	287	65	120	12.5	25	20	40	10	130	25	16
LPTB500L	25/30	0.2		253							20									
LPTB500M	50/60	0.4	180	253	166	A20C	170	70	150	327	20	140	15	30	25	12	140	31	20	
LPTB500H	100/120	0.75		289																20

Unit: mm

Nominal stroke	Thrust		A	XA		LA
	kN	{ kgf }		MIN	MAX	
200	4.90	500	340	435	635	161
300			440	545	845	
400			540	655	1055	
500			640	765	1265	76.5
600			740	870	1470	
800			940	1090	1890	

Approximate mass of main body

Unit: kg

Model	200	300	400	500	600	800
LPTB500S	35	36	37	38	39	41
LPTB500L	32	33	34	35	36	38
LPTB500M	34	35	36	37	38	40
LPTB500H	43	44	45	46	47	49

1. This diagram shows a power cylinder with an external limit switch for stroke adjustment.
2. If the stroke is 300mm or less and a limit switch for stroke adjustment is equipped, the limit switch is vertically mounted. Note that the LA dimension becomes larger. (See ④ in Cautions for layout on page 92.)
3. Mechanical stroke has a margin of approximately 10mm on both sides for the nominal stroke.
4. For the cylinder with bellows, the stroke will also not change.
5. For connector part dimensions of the motor terminal box, refer to page 115.

## Options

### ■ Bellows ( - J)

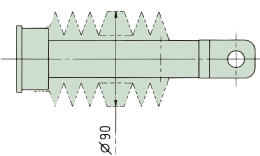

### ■ I-type end fitting ( - I)

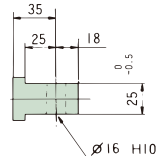

Note) Shipped as attached to the main body. The XA dimensions are the same as the standard U-type end fitting.

### ■ Clevis fitting ( - C)

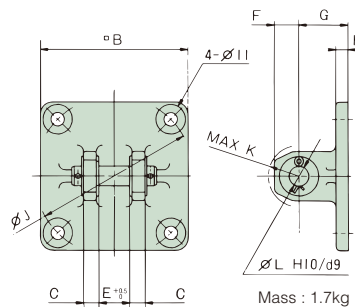

Note) Shipped attached to the main body. If it needs to be shipped individually, consult us.

### ■ Trunnion fitting (LPTB500-T)

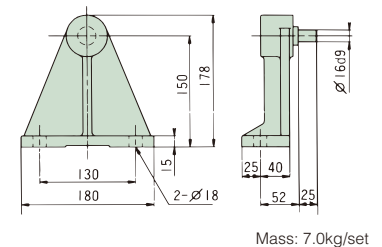

Mass: 7.0kg/set

Note) Apply grease to the trunnion pin and trunnion hole before mounting.

\* Dimensions with no tolerance described have general tolerance, and their sizes become larger by approximately 2 to 5mm from the described dimensions. When designing the machine, take the margin into consideration.

**Dimensions Table T Series 500**

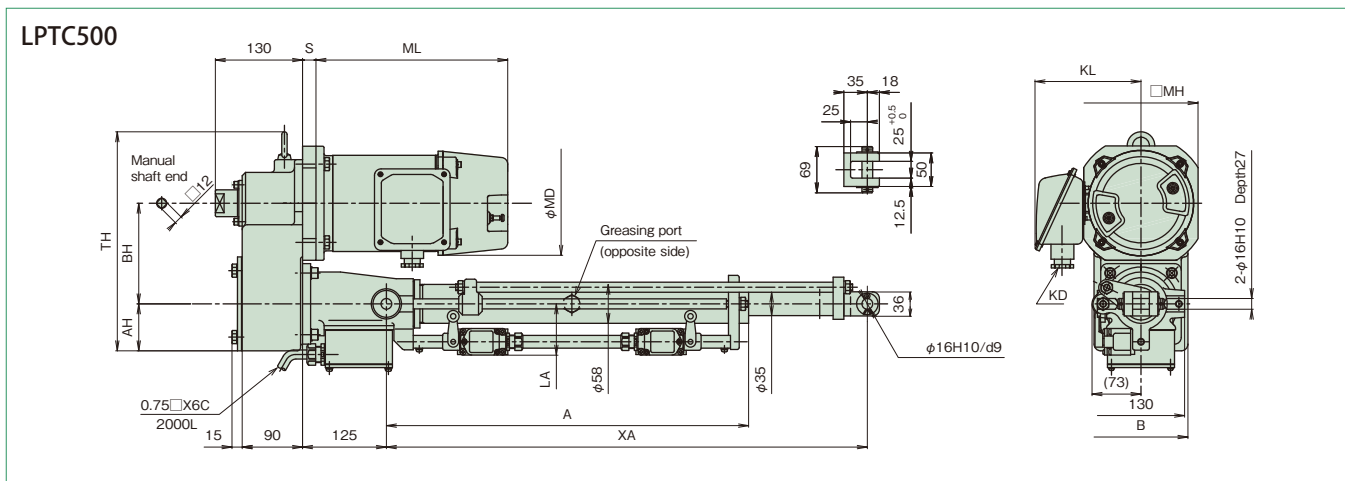

Unit: mm

Model	Nominal speed mm/s 50/60Hz	Motor kW	MD	ML	KL	KD	MH	AH	BH	TH	S	B	C	E	F	G	H	J	K	L
LPTC500S	12.5/15	0.1	132	231	125	SK-14L	120	60	125	287	65	120	12.5	25	20	40	10	130	25	16
LPTC500L	25/30	0.2		253							20									
LPTC500M	50/60	0.4	180	289	166	A20C	170	70	150	327	20	140	15	30	25	12	140	31	20	
LPTC500H	100/120	0.75		20																

Unit: mm

Nominal stroke	Thrust		A	XA		LA
	kN	{ kgf }		MIN	MAX	
200	4.90	500	340	435	635	161
300			440	545	845	
400			540	655	1055	
500			640	765	1265	76.5
600			740	870	1470	
800			940	1090	1890	

Approximate mass of main body

Unit: kg

Model	200	300	400	500	600	800
LPTC500S	39	40	41	42	43	45
LPTC500L	36	37	38	39	40	42
LPTC500M	38	39	40	41	42	44
LPTC500H	47	48	49	50	51	53

1. This diagram shows a power cylinder with an external limit switch for stroke adjustment.
2. If the stroke is 300mm or less and a limit switch for stroke adjustment is equipped, the limit switch is vertically mounted. Note that the LA dimension becomes larger. (See ④ in Cautions for layout on page 92.)
3. Mechanical stroke has a margin of approximately 10mm on both sides for the nominal stroke.
4. For the cylinder with bellows, the stroke will also not change.
5. Use TC type model in brake individual turnoff.
6. For connector part dimensions of the motor terminal box, refer to page 115.
7. The terminal box lead-out direction in this diagram is for the H speed. For the S, L, and M speeds, the direction is the same as the LPTC250 type.

**Options**

■ Bellows ( - J )

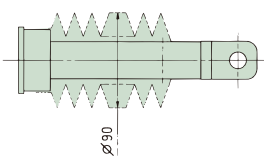

■ I-type end fitting ( - I ) ■ Clevis fitting ( - C )

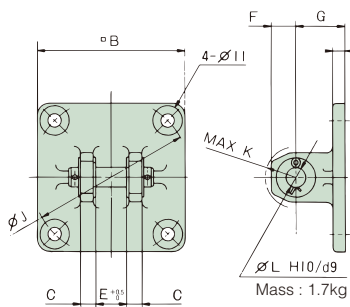
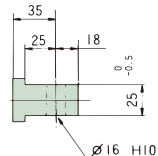

■ Trunnion fitting (LPTB500-T)

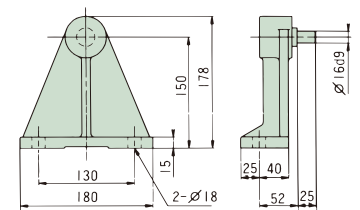

Mass: 7.0kg/set

Note) Shipped as attached to the main body. The XA dimensions are the same as the standard U-type end fitting.

Note) Shipped attached to the main body. If it needs to be shipped individually, consult us.

Note) Apply grease to the trunnion pin and trunnion hole before mounting.

\* Dimensions with no tolerance described have general tolerance, and their sizes become larger by approximately 2 to 5mm from the described dimensions. When designing the machine, take the margin into consideration.

# Dimensions Table T Series 1000

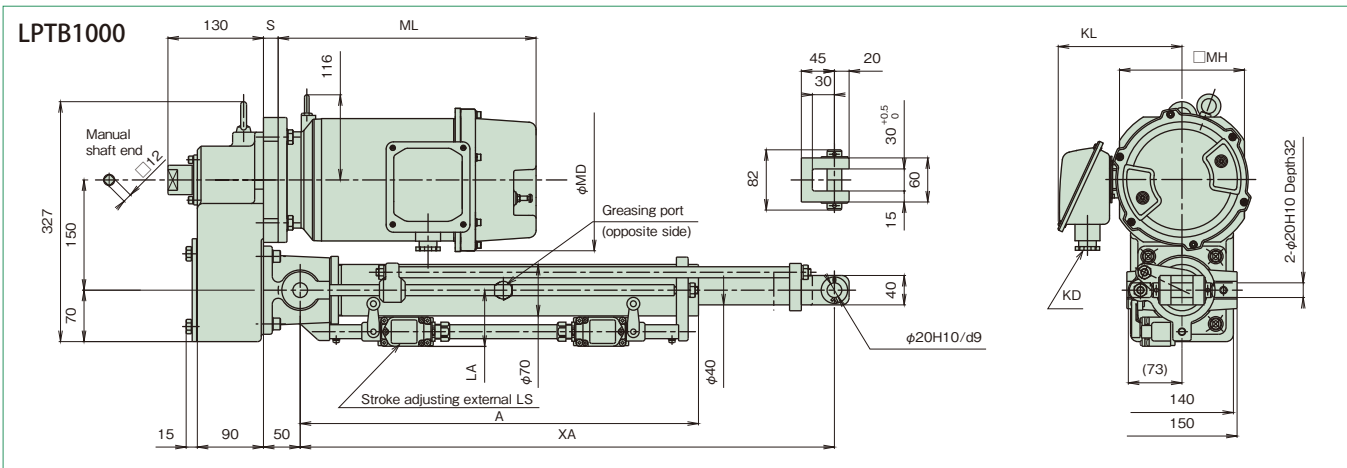

Unit: mm

Model	Nominal speed mm/s 50/60Hz	Motor kW	MD	ML	KL	KD	MH	S
LPTB1000S	12.5/15	0.2	132	231	125	SK-14L	120	65
LPTB1000L	25/30	0.4		253				—
LPTB1000M	50/60	0.75	180	289	166	A20C	170	20
LPTB1000H	100/120	1.5	194	351	178			

Unit: kg

Nominal stroke	200	300	400	500	600	800	1000
LPTB1000S	42	44	45	47	48	51	54
LPTB1000L	40	42	43	45	46	49	52
LPTB1000M	46	48	49	51	52	55	58
LPTB1000H	50	52	53	55	56	59	62

Unit: mm

Nominal stroke	Thrust		A	XA		LA
	kN	{ kgf }		MIN	MAX	
200	9.80	1000	360	465	665	161
300			460	575	875	
400			560	685	1085	
500			660	795	1295	
600			760	900	1500	
800	7.84	800	960	1120	1920	76.5
1000			1160	1340	2340	

- This diagram shows a power cylinder with an external limit switch for stroke adjustment.
- If the stroke is 300mm or less and a limit switch for stroke adjustment is equipped, the limit switch is vertically mounted. Note that the LA dimension becomes larger. (See ④ in Cautions for layout on page 92.)
- Mechanical stroke has a margin of approximately 10mm on both sides for the nominal stroke.
- For the cylinder with bellows, the stroke will also not change.
- For connector part dimensions of the motor terminal box, refer to page 115.

## Options

### ■ Bellows ( - J )

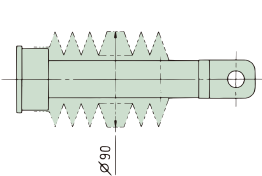

### ■ I-type end fitting ( - I )

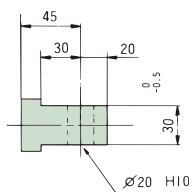

Note) Shipped as attached to the main body.  
The XA dimensions are the same as the standard U-type end fitting.

### ■ Clevis fitting ( - C )

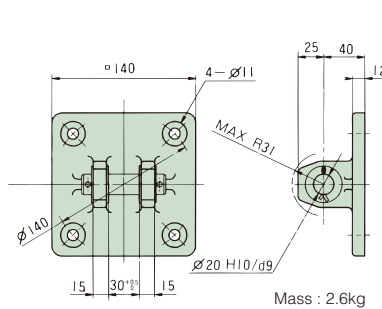

Note) Shipped attached to the main body.  
If it needs to be shipped individually, consult us.

### ■ Trunnion fitting (LPTB1000-T)

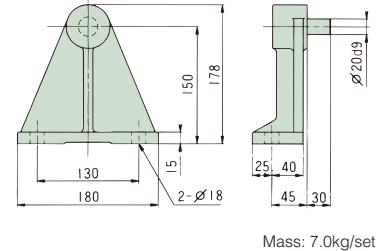

Note) Apply grease to the trunnion pin and trunnion hole before mounting.

\* Dimensions with no tolerance described have general tolerance, and their sizes become larger by approximately 2 to 5mm from the described dimensions. When designing the machine, take the margin into consideration.

# Dimensions Table T Series 1000

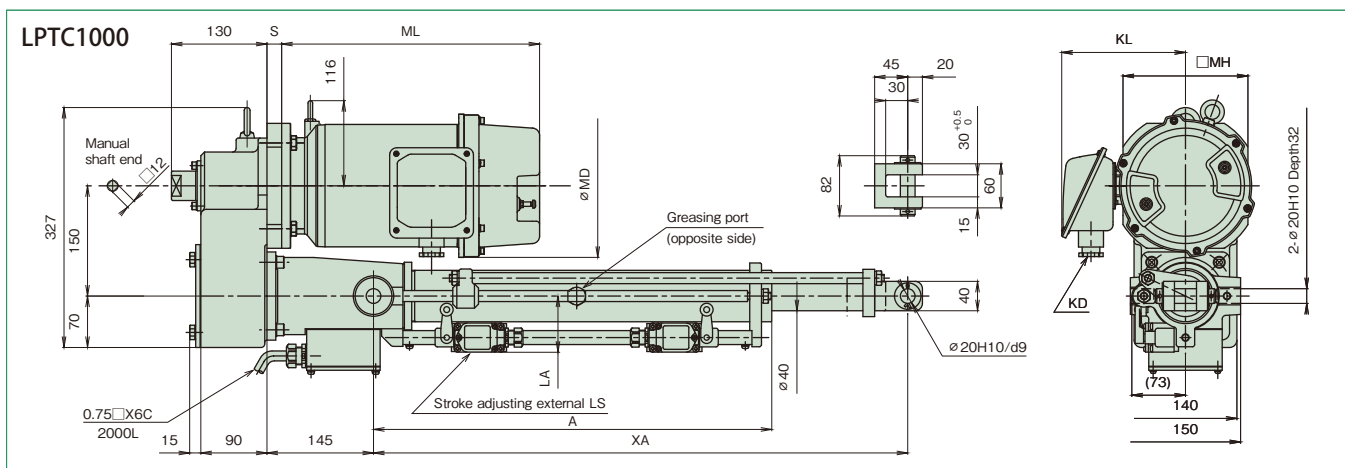

Unit: mm

Model	Nominal speed mm/s 50/60Hz	Motor kW	MD	ML	KL	KD	MH	S
LPTC1000S	12.5/15	0.2	132	231	125	SK-14L	120	65
LPTC1000L	25/30	0.4		253				—
LPTC1000M	50/60	0.75	180	289	166	A20C	170	20
LPTC1000H	100/120	1.5	194	351	178			

Unit: mm

Nominal stroke	Thrust		A	XA		LA
	kN	{ kgf }		MIN	MAX	
200	9.80	1000	360	465	665	161
300			460	575	875	
400			560	685	1085	
500			660	795	1295	
600			760	900	1500	
800	7.84	800	960	1120	1920	76.5
1000			1160	1340	2340	

Approximate mass of main body Unit: kg

Nominal stroke	200	300	400	500	600	800	1000
LPTC1000S	48	50	51	53	54	57	60
LPTC1000L	46	48	49	51	52	55	58
LPTC1000M	52	54	55	57	58	61	64
LPTC1000H	56	58	59	61	62	65	68

1. This diagram shows a power cylinder with an external limit switch for stroke adjustment.
2. If the stroke is 300mm or less and a limit switch for stroke adjustment is equipped, the limit switch is vertically mounted. Note that the LA dimension becomes larger. (See ④ in Cautions for layout on page 92.)
3. Mechanical stroke has a margin of approximately 10mm on both sides for the nominal stroke.
4. For the cylinder with bellows, the stroke will also not change.
5. Use TC type model in brake individual turnover.
6. When the model of the TC type nominal stroke 1000mm is used, press and stop cannot be carried out near the maximum stroke in terms of buckling strength.
7. For connector part dimensions of the motor terminal box, refer to page 115.

## Options

### ■ Bellows ( - J )

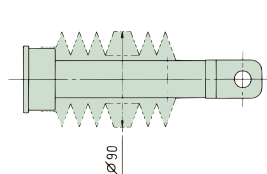

### ■ I-type end fitting ( - I )

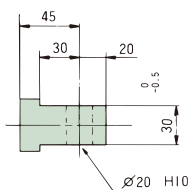

Note) Shipped as attached to the main body.  
The XA dimensions are the same as the standard U-type end fitting.

### ■ Clevis fitting ( - C )

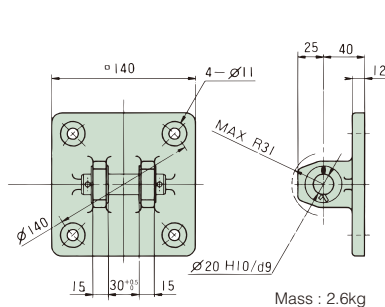

Note) Shipped attached to the main body.  
If it needs to be shipped individually, consult us.

### ■ Trunnion fitting (LPTB1000-T)

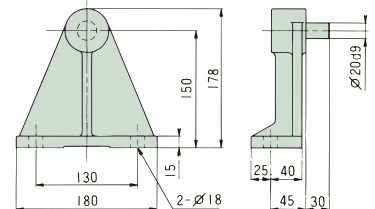

Mass: 7.0kg/set

Note) Apply grease to the trunnion pin and trunnion hole before mounting.

\* Dimensions with no tolerance described have general tolerance, and their sizes become larger by approximately 2 to 5mm from the described dimensions. When designing the machine, take the margin into consideration.

# Dimensions Table T Series 2000

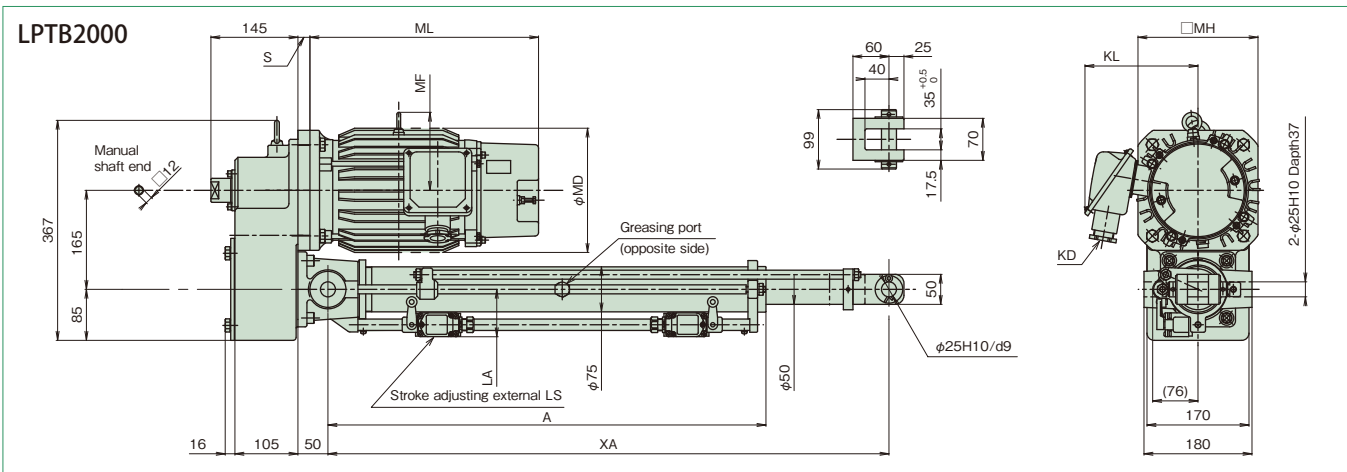

Unit: mm

Model	Nominal speed mm/s 50/60Hz	Motor kW	MD	ML	MF	KL	KD	MH	S
LPTB2000S	12.5/15	0.4	132	253	-	125	SK-14L	120	70
LPTB2000L	25/30	0.75	180	289		166	A20C	170	-
LPTB2000M	50/60	1.5	194	351		178	A25C	200	20
LPTB2000H	75/90	2.2	207	381	130	190	A25C	200	20

Approximate mass of main body

Unit: kg

Model	200	300	400	500	600	800	1000	1200
LPTB2000S	56	58	60	62	64	68	72	76
LPTB2000L	55	57	59	61	63	67	71	75
LPTB2000M	59	61	63	65	67	71	75	79
LPTB2000H	70	72	74	76	78	82	86	90

Unit: mm

Nominal stroke	Thrust		A	XA		LA
	kN	{ kgf }		MIN	MAX	
200	19.6	2000	400	520	720	164
300			500	630	930	
400			600	740	1140	
500			700	850	1350	
600			800	955	1555	
800			1000	1175	1975	
1000	15.6	1600	1200	1395	2395	79
1200	12.2	1250	1400	1615	2815	

- This diagram shows a power cylinder with an external limit switch for stroke adjustment.
- If the stroke is 300mm or less and a limit switch for stroke adjustment is equipped, the limit switch is vertically mounted. Note that the LA dimension becomes larger. (See ④ in Cautions for layout on page 92.)
- Mechanical stroke has a margin of approximately 10mm on both sides for the nominal stroke.
- For the cylinder with bellows, the stroke will also not change.
- For connector part dimensions of the motor terminal box, refer to page 115.

## Options

### ■ Bellows ( - J )

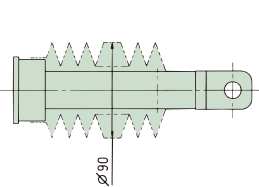

### ■ I-type end fitting ( - I )

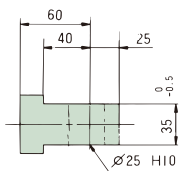

Note) Shipped as attached to the main body.  
The XA dimensions are the same as the standard U-type end fitting.

### ■ Clevis fitting ( - C )

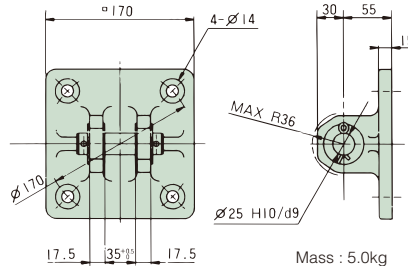

Note) Shipped attached to the main body.  
If it needs to be shipped individually, consult us.

Mass : 5.0kg

### ■ Trunnion fitting (LPTB2000-T)

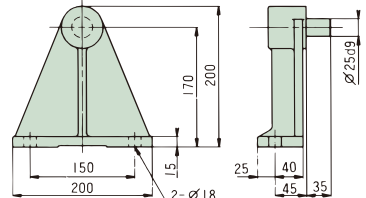

Mass: 9.2kg/set

Note) Apply grease to the trunnion pin and trunnion hole before mounting.

\* Dimensions with no tolerance described have general tolerance, and their sizes become larger by approximately 2 to 5mm from the described dimensions. When designing the machine, take the margin into consideration.

# Dimensions Table T Series 2000

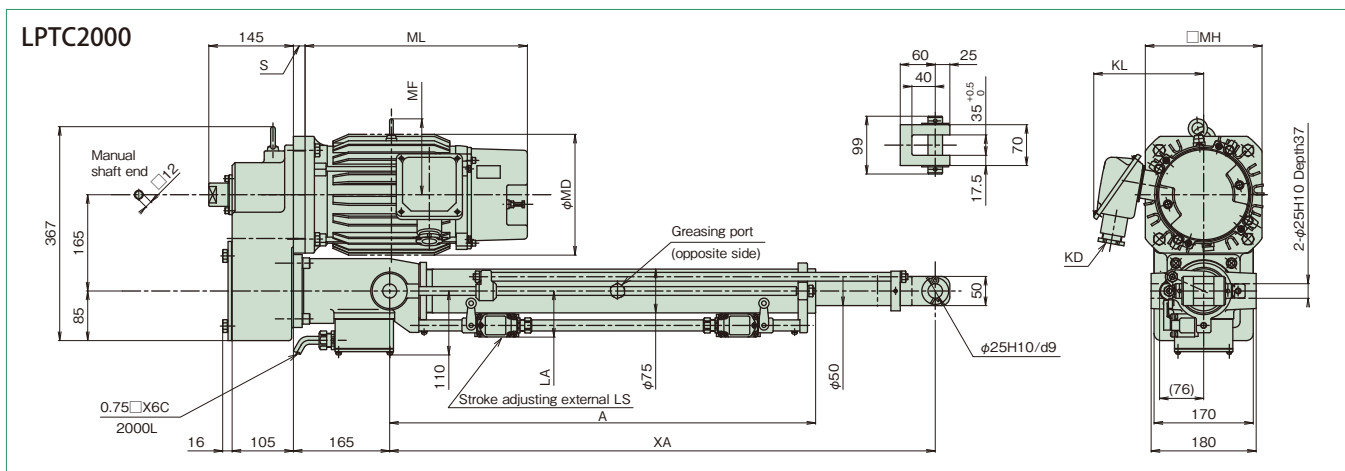

Unit: mm

Model	Nominal speed mm/s 50/60Hz	Motor kW	MD	ML	MF	KL	KD	MH	S
LPTC2000S	12.5/15	0.4	132	253		125	SK-14L	120	70
LPTC2000L	25/30	0.75	180	289	—	166	A20C	170	—
LPTC2000M	50/60	1.5	194	351		178			
LPTC2000H	75/90	2.2	207	381	130	190	A25C	200	20

Approximate mass of main body

Unit: kg

Model	200	300	400	500	600	800	1000	1200
LPTC2000S	64	66	68	70	72	76	80	84
LPTC2000L	63	65	67	69	71	75	79	83
LPTC2000M	67	69	71	73	75	79	83	87
LPTC2000H	78	80	82	84	86	90	94	98

Unit: mm

Nominal stroke	Thrust		A	XA		LA
	kN	{ kgf }		MIN	MAX	
200	19.6	2000	400	520	720	164
300			500	630	930	
400			600	740	1140	
500			700	850	1350	
600			800	955	1555	
800			1000	1175	1975	
1000	15.6	1600	1200	1395	2395	79
1200	12.2	1250	1400	1615	2815	

1. This diagram shows a power cylinder with an external limit switch for stroke adjustment.
2. If the stroke is 300mm or less and a limit switch for stroke adjustment is equipped, the limit switch is vertically mounted. Note that the LA dimension becomes larger. (See ④ in Cautions for layout on page 92.)
3. Mechanical stroke has a margin of approximately 10mm on both sides for the nominal stroke.
4. For the cylinder with bellows, the stroke will also not change.
5. Use TC type model in brake individual turnoff.
6. When the model of the TC type nominal stroke 1000 or 1200mm is used, press and stop cannot be carried out near the maximum stroke in terms of buckling strength.
7. For connector part dimensions of the motor terminal box, refer to page 115.

## Options

### ■ Bellows ( -J)

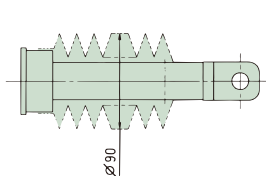

### ■ I-type end fitting ( -I) ■ Clevis fitting ( -C)

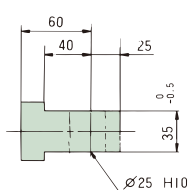

Note) Shipped as attached to the main body.  
The XA dimensions are the same as the standard U-type end fitting.

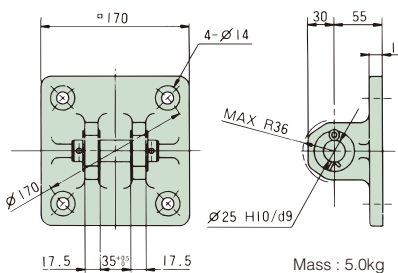

Note) Shipped attached to the main body.  
If it needs to be shipped individually, consult us.

### ■ Trunnion fitting (LPTB2000-T)

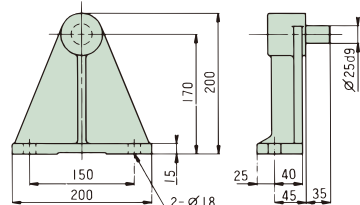

Mass: 9.2kg/set

Note) Apply grease to the trunnion pin and trunnion hole before mounting.

\* Dimensions with no tolerance described have general tolerance, and their sizes become larger by approximately 2 to 5mm from the described dimensions. When designing the machine, take the margin into consideration.



# Dimensions Table T Series 4000

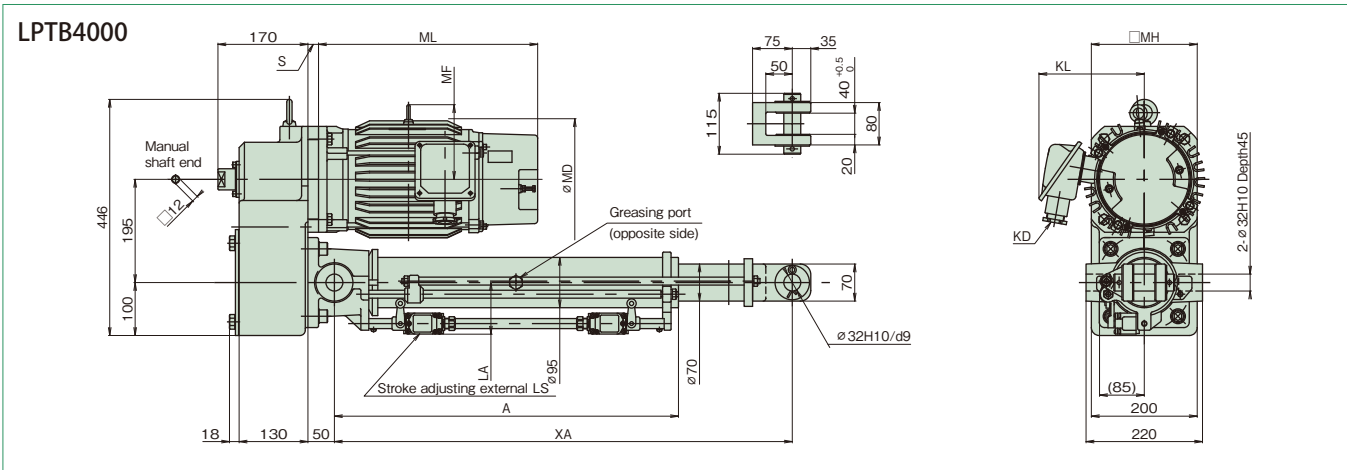

Unit: mm

Model	Nominal speed mm/s 50/60Hz	Motor kW	MD	ML	MF	KL	KD	MH	S
LPTB4000S	9/11	0.75	180	289		166		170	90
LPTB4000L	25/30	1.5	194	351		178	A20C		—
LPTB4000M	35/42	2.2	207	381	130	190		200	20
LPTB4000H	60/72	3.7	229	414	141	201	A25C		

Unit: kg

Model	Approximate mass of main body									
	Nominal stroke	200	300	400	500	600	800	1000	1200	1500
LPTB4000S		90	94	97	101	104	111	118	125	136
LPTB4000L		87	91	94	98	101	108	115	122	133
LPTB4000M		97	101	104	108	111	118	125	132	143
LPTB4000H		116	120	123	127	130	137	144	151	162

Unit: mm

Nominal stroke	Thrust		A	XA		LA
	kN	{ kgf }		MIN	MAX	
200	39.2	4000	440	585	785	182
300			550	695	995	
400			650	805	1205	
500			750	910	1410	
600			850	1020	1620	
800			1050	1235	2035	
1000			1250	1450	2450	
1200			1450	1670	2870	
1500	33.3	3400	1750	1995	3495	97.5

- This diagram shows a power cylinder with an external limit switch for stroke adjustment.
- If the stroke is 300mm or less and a limit switch for stroke adjustment is equipped, the limit switch is vertically mounted. Note that the LA dimension becomes larger. (See ④ in Cautions for layout on page 92.)
- Mechanical stroke has a margin of approximately 10mm on both sides for the nominal stroke.
- For the cylinder with bellows, the stroke will also not change.
- For connector part dimensions of the motor terminal box, refer to page 115.

## Options

### ■ Bellows ( - J )

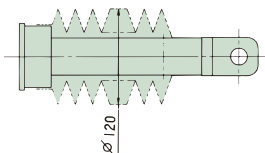

### ■ I-type end fitting ( - I ) ■ Clevis fitting ( - C )

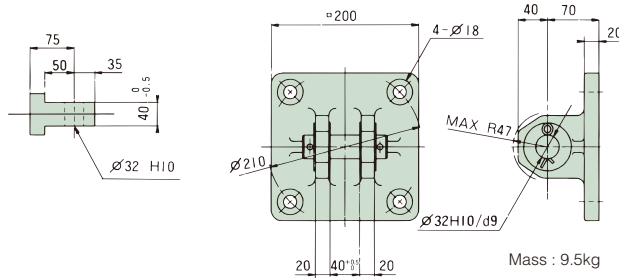

Note) Shipped as attached to the main body.  
The XA dimensions are the same as the standard U-type end fitting.

Note) Shipped attached to the main body.  
If it needs to be shipped individually, consult us.

### ■ Trunnion fitting (LPTB4000-T)

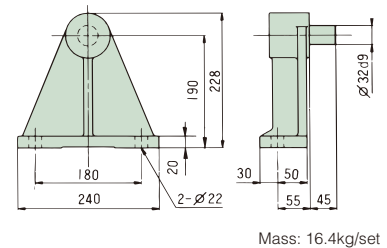

Note) Apply grease to the trunnion pin and trunnion hole before mounting.

\* Dimensions with no tolerance described have general tolerance, and their sizes become larger by approximately 2 to 5mm from the described dimensions. When designing the machine, take the margin into consideration.

**Dimensions Table T Series 4000**

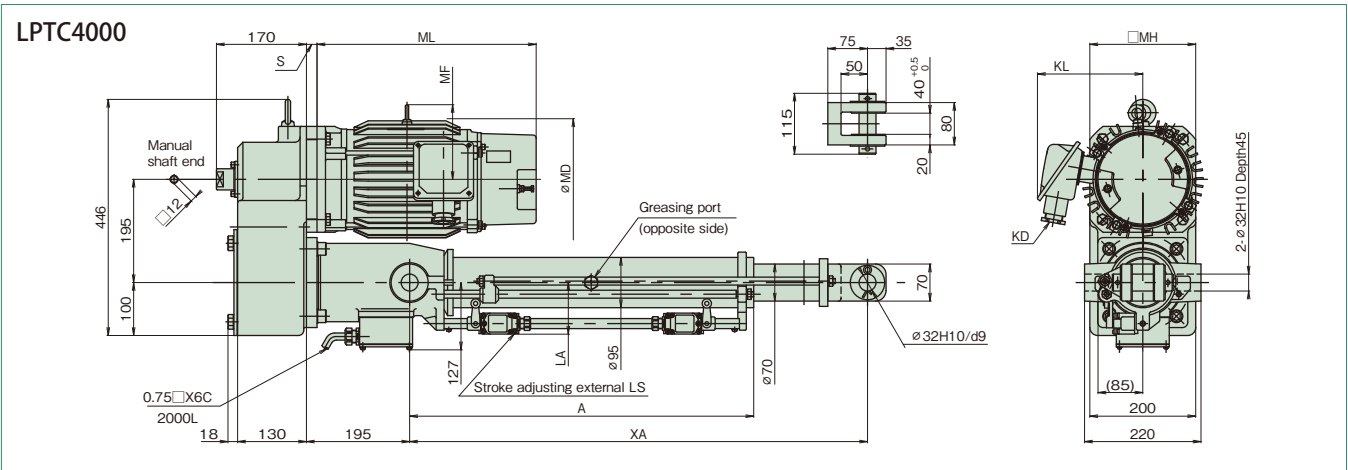

Unit: mm

Model	Nominal speed mm/s 50/60Hz	Motor kW	MD	ML	MF	KL	KD	MH	S
LPTC4000S	9/11	0.75	180	289	-	166	A20C	170	90
LPTC4000L	25/30	1.5	194	351	-	178	A20C	-	-
LPTC4000M	35/42	2.2	207	381	130	190	A25C	200	20
LPTC4000H	60/72	3.7	229	414	141	201	A25C	200	20

Unit: mm

Nominal stroke	Thrust		A	XA		LA
	kN	{ kgf }		MIN	MAX	
200	39.2	4000	440	585	785	182
300			550	695	995	
400			650	805	1205	
500			750	910	1410	
600			850	1020	1620	
800			1050	1235	2035	
1000			1250	1450	2450	
1200			1450	1670	2870	
1500	33.3	3400	1750	1995	3495	97.5

Approximate mass of main body Unit: kg

Model	200	300	400	500	600	800	1000	1200	1500
LPTC4000S	105	109	112	116	119	126	133	140	151
LPTC4000L	102	106	109	113	116	123	130	137	148
LPTC4000M	112	116	119	123	126	133	140	147	158
LPTC4000H	131	135	138	142	145	152	159	166	177

- This diagram shows a power cylinder with an external limit switch for stroke adjustment.
- If the stroke is 300mm or less and a limit switch for stroke adjustment is equipped, the limit switch is vertically mounted. Note that the LA dimension becomes larger. (See ④ in Cautions for layout on page 92.)
- Mechanical stroke has a margin of approximately 10mm on both sides for the nominal stroke.
- For the cylinder with bellows, the stroke will also not change.
- Use TC type model in brake individual turnover.
- When the model of the TC type nominal stroke 1500mm is used, press and stop cannot be carried out near the maximum stroke in terms of buckling strength.
- For connector part dimensions of the motor terminal box, refer to page 115.

**Options**

■ Bellows ( - J )

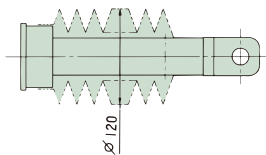

■ I-type end fitting ( - I ) ■ Clevis fitting ( - C )

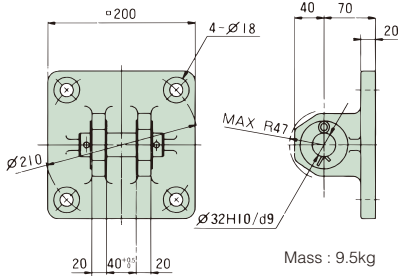
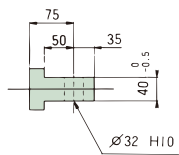

■ Trunnion fitting (LPTB4000-T)

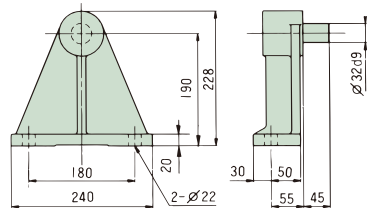

Note) Shipped as attached to the main body. The XA dimensions are the same as the standard U-type end fitting.

Note) Shipped attached to the main body. If it needs to be shipped individually, consult us.

Note) Apply grease to the trunnion pin and trunnion hole before mounting.

\* Dimensions with no tolerance described have general tolerance, and their sizes become larger by approximately 2 to 5mm from the described dimensions. When designing the machine, take the margin into consideration.

# Dimensions Table T Series 6000

## LPTB6000

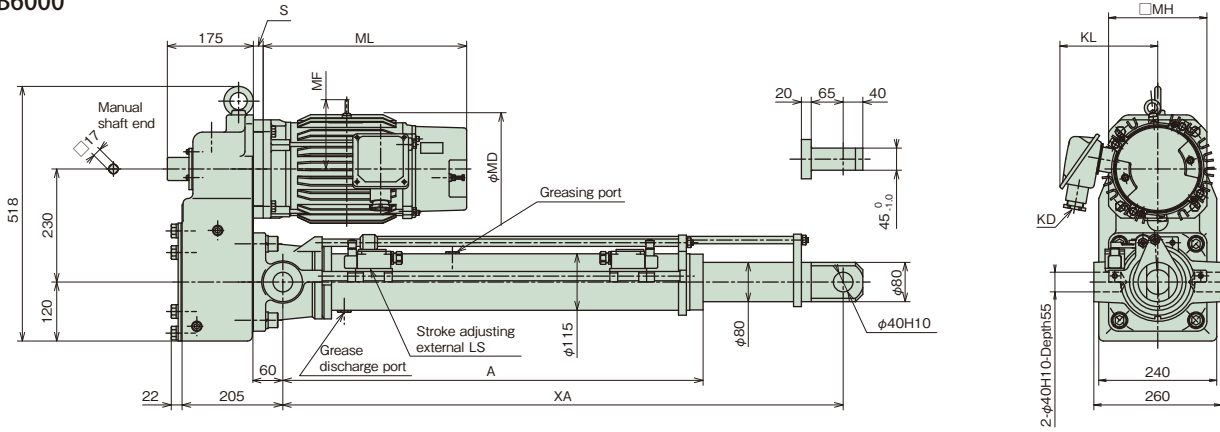

## LPTC6000

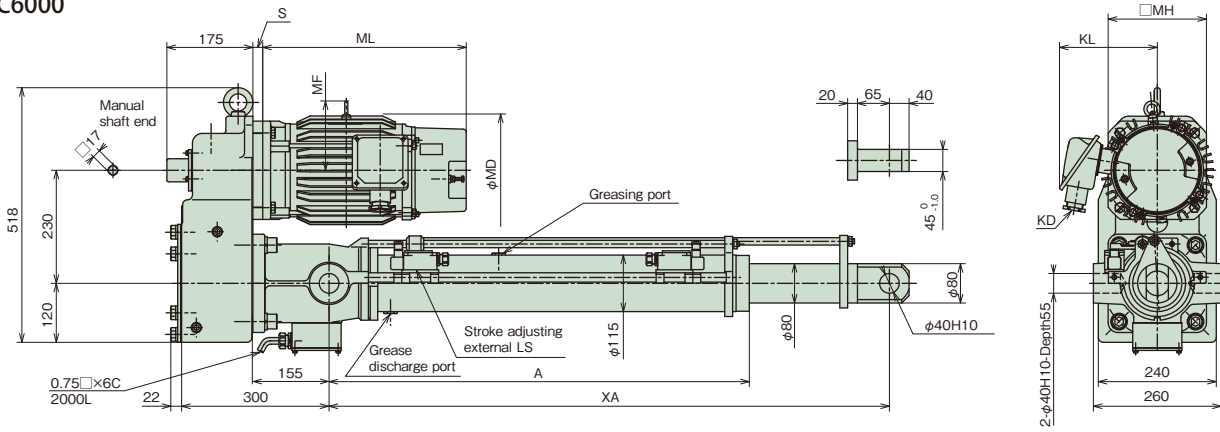

Unit: mm

Model	Nominal speed mm/s 50/60Hz	Motor kW	MD	ML	MF	KL	KD	MH	S
LPTB6000S	6.3/7.6	0.75	180	289	—	166	A20C	170	90
LPTC6000S									
LPTB6000L	17.5/21	1.5	194	351	—	178	A25C	200	20
LPTC6000L									
LPTB6000M	25/30	2.2	207	381	130	190	A25C	200	20
LPTC6000M									
LPTB6000H	42/50	3.7	229	414	141	201	A25C	200	20
LPTC6000H									

Unit: mm

Nominal stroke	Thrust		A	XA	
	kN	{kgf}		MIN	MAX
500	58.8	6000	855	1010	1510
1000			1355	1560	2560
1500			1955	2210	3710

Approximate mass of main body

Unit: kg

Model	Nominal stroke	500	1000	1500
LPTB6000S		143	168	193
LPTC6000S		165	190	215
LPTB6000L		151	176	201
LPTC6000L		173	198	223
LPTB6000M		157	182	207
LPTC6000M		179	204	229
LPTB6000H		172	197	222
LPTC6000H		194	219	244

1. This diagram shows a power cylinder with an external limit switch for stroke adjustment.
2. Mechanical stroke has a margin of approximately 10mm on both sides for the nominal stroke.
3. For the cylinder with bellows, the stroke will also not change.
4. Use TC type model in brake individual turnoff.
5. When the model of the TC type nominal stroke 1500mm is used, press and stop cannot be carried out near the maximum stroke in terms of buckling strength.
6. For connector part dimensions of the motor terminal box, refer to page 115.

## Options

### ■ Bellows ( - J )

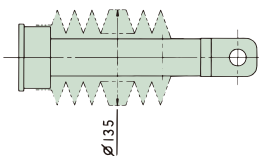

### ■ Clevis fitting ( - C )

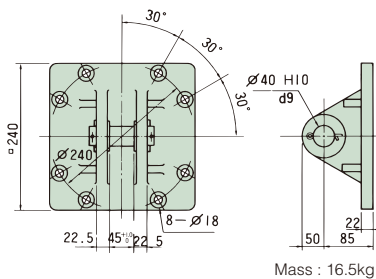

Note) Shipped attached to the main body.  
If it needs to be shipped individually, consult us.

### ■ Trunnion fitting (LPTB6000-T)

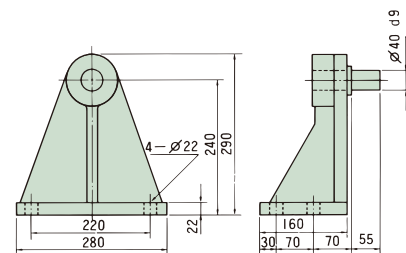

Note) Apply grease to the trunnion pin and trunnion hole before mounting.

\* Dimensions with no tolerance described have general tolerance, and their sizes become larger by approximately 2 to 5mm from the described dimensions. When designing the machine, take the margin into consideration.

**Dimensions Table T Series 8000**

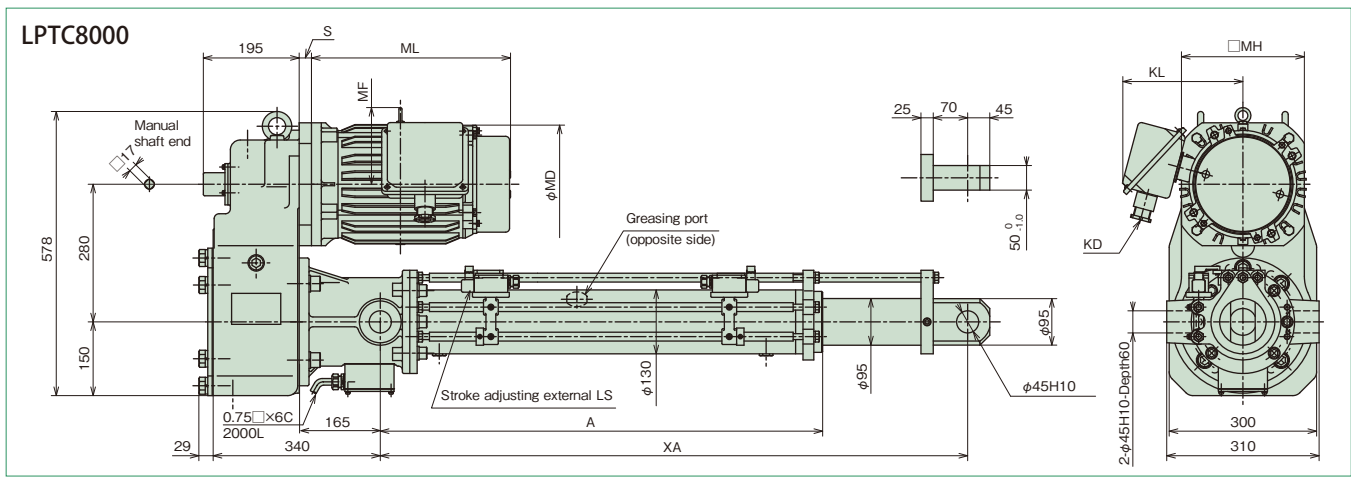
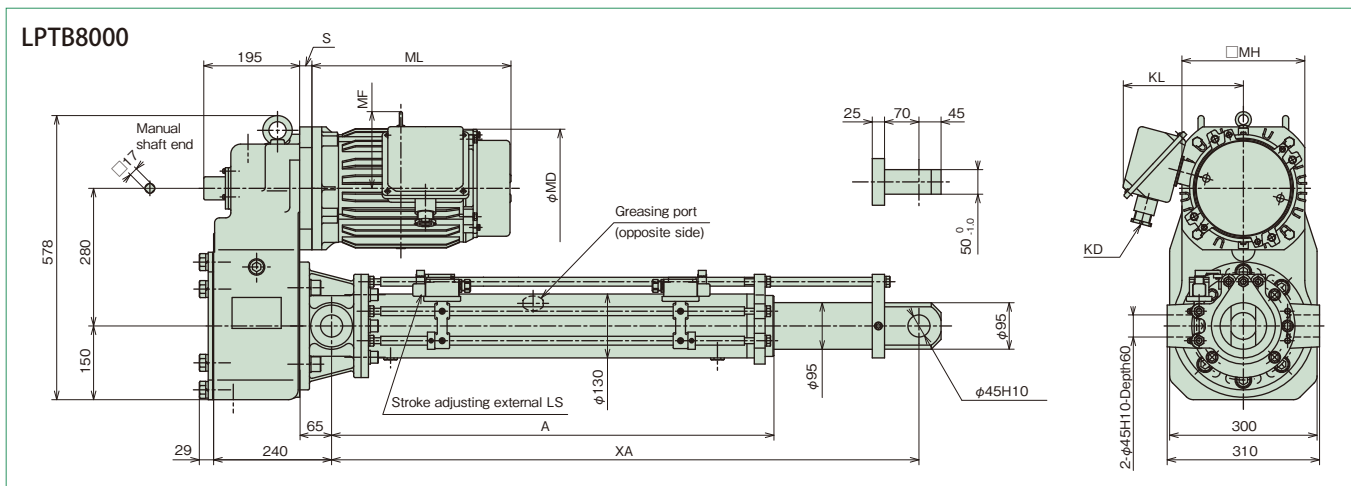

Unit: mm

Model	Nominal speed mm/s 50/60Hz	Motor kW	MD	ML	MF	KL	KD	MH	S
LPTB8000S	10/12	1.5	194	351	—	178	A20C	170	137
LPTC8000S	10/12	1.5	194	351	—	178	A20C	170	137
LPTB8000L	20/24	2.2	207	381	130	190	A25C	200	—
LPTC8000L	20/24	2.2	207	381	130	190		200	—
LPTB8000M	30/36	3.7	229	414	141	201	A25C	250	25
LPTC8000M	30/36	3.7	229	414	141	201		250	25
LPTB8000H	43/52	5.5	265	403	156	245	A25C	250	25
LPTC8000H	43/52	5.5	265	403	156	245		250	25

Unit: mm

Nominal stroke	Thrust		A	XA	
	kN	{ kgf }		MIN	MAX
500	78.4	8000	900	1065	1565
1000			1400	1615	2615
1500			1900	2165	3665

Unit: kg

Model	Nominal stroke	500	1000	1500
LPTB8000S	500	224	254	284
LPTC8000S	500	254	284	314
LPTB8000L	1000	212	242	272
LPTC8000L	1000	242	272	302
LPTB8000M	1500	230	260	290
LPTC8000M	1500	260	290	320
LPTB8000H	1500	241	271	301
LPTC8000H	1500	271	301	331

1. This diagram shows a power cylinder with an external limit switch for stroke adjustment.
2. Mechanical stroke has a margin of approximately 10mm on both sides for the nominal stroke.
3. For the cylinder with bellows, the stroke will also not change.
4. Use TC type model in brake individual turnoff.
5. When the model of the TC type nominal stroke 1500mm is used, press and stop cannot be carried out near the maximum stroke in terms of buckling strength.
6. For connector part dimensions of the motor terminal box, refer to page 115.

**Options**

■ Bellows ( -J)

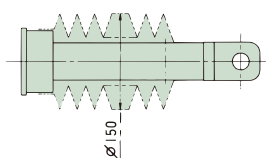

■ Clevis fitting ( -C)

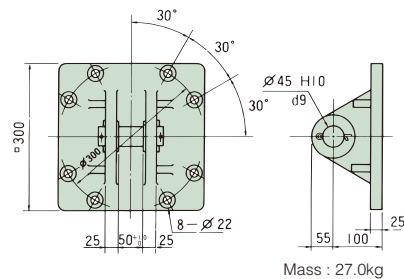

■ Trunnion fitting (LPTB8000-T)

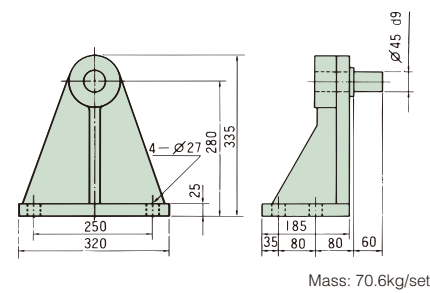

Note) Shipped attached to the main body.  
If it needs to be shipped individually, consult us.

Note) Apply grease to the trunnion pin and trunnion hole before mounting.

\* Dimensions with no tolerance described have general tolerance, and their sizes become larger by approximately 2 to 5mm from the described dimensions. When designing the machine, take the margin into consideration.

# Dimensions Table T Series 12000

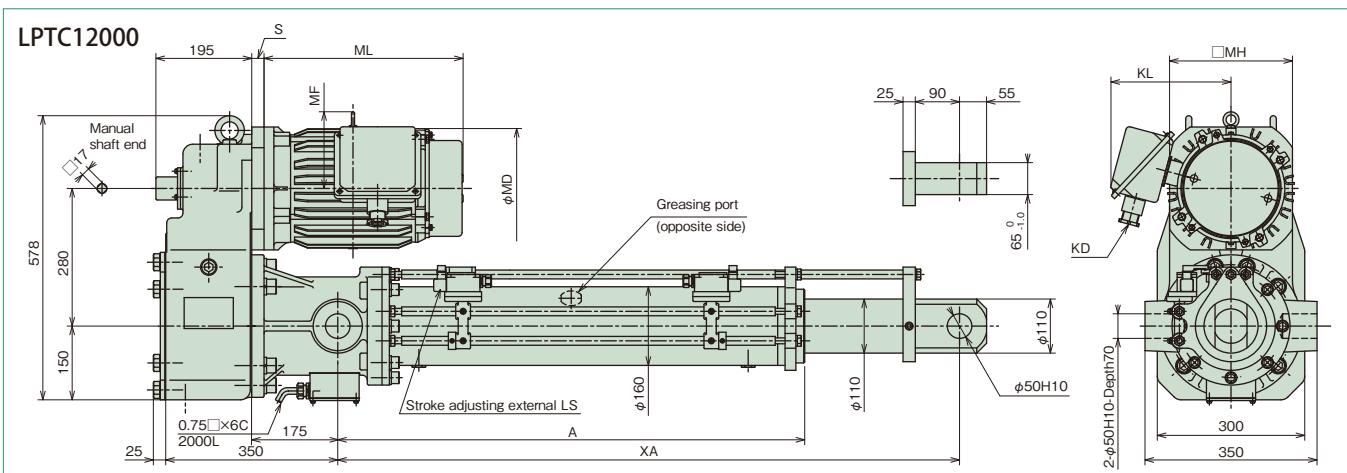
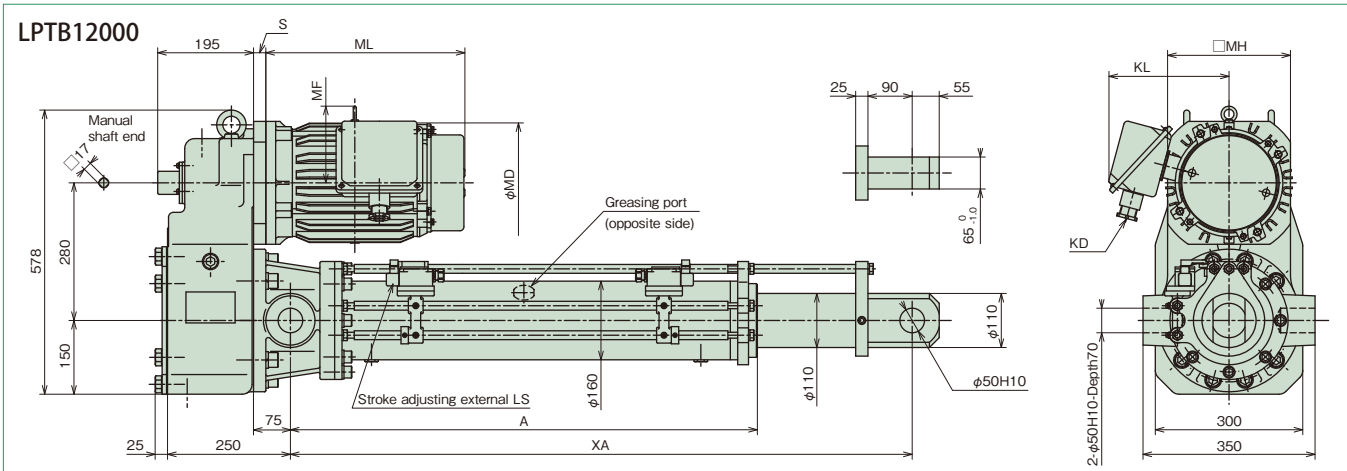

Unit: mm

Model	Nominal speed mm/s 50/60Hz	Motor kW	MD	ML	MF	KL	KD	MH	S
LPTB12000L LPTC12000L	10/12	2.2	207	381	130	190		200	145
LPTB12000M LPTC12000M	18/22	3.7	229	414	141	201	A25C	250	145
LPTB12000H LPTC12000H	30/36	5.5	265	403	156	245		250	25

Unit: kg

Approximate mass of main body

Model	Nominal stroke	500	1000	1500	2000
LPTB12000L		270	312	354	396
LPTC12000L		309	351	393	435
LPTB12000M		285	327	369	411
LPTC12000M		324	366	408	450
LPTB12000H		295	337	379	421
LPTC12000H		334	376	418	460

Unit: mm

Nominal stroke	Thrust		A	XA	
	kN	{ kgf }		MIN	MAX
500	117	12000	950	1135	1635
1000			1450	1685	2685
1500			1950	2235	3735
2000			2450	2785	4785

1. This diagram shows a power cylinder with an external limit switch for stroke adjustment.
2. Mechanical stroke has a margin of approximately 10mm on both sides for the nominal stroke.
3. For the cylinder with bellows, the stroke will also not change.
4. Use TC type model in brake individual turnover.
5. When the model of the TC type nominal stroke 2000mm is used, press and stop cannot be carried out near the maximum stroke in terms of buckling strength.
6. For connector part dimensions of the motor terminal box, refer to page 115.

## Options

### ■ Bellows ( - J )

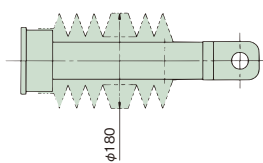

### ■ Clevis fitting ( - C )

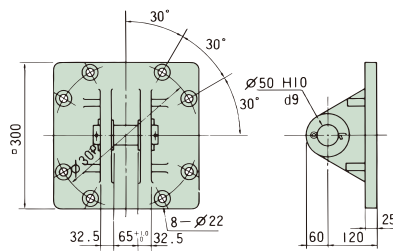

Mass : 33.0kg

Note) Shipped attached to the main body.  
If it needs to be shipped individually, consult us.

### ■ Trunnion fitting (LPTB12000-T)

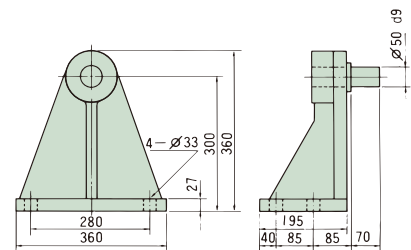

Mass: 84.4kg/set

Note) Apply grease to the trunnion pin and trunnion hole before mounting.

\* Dimensions with no tolerance described have general tolerance, and their sizes become larger by approximately 2 to 5mm from the described dimensions. When designing the machine, take the margin into consideration.

**Dimensions Table T Series 16000**

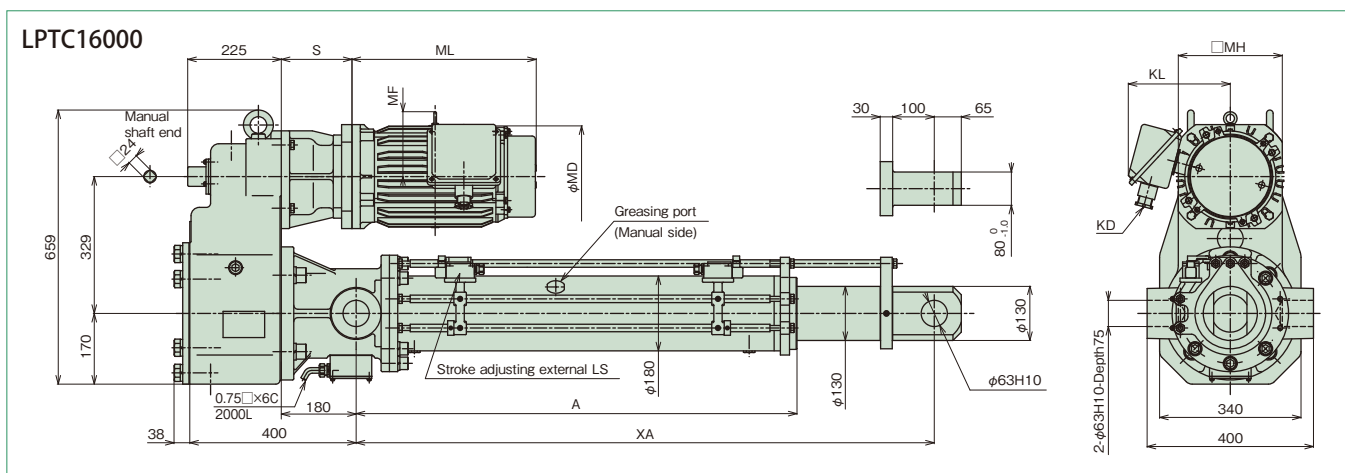
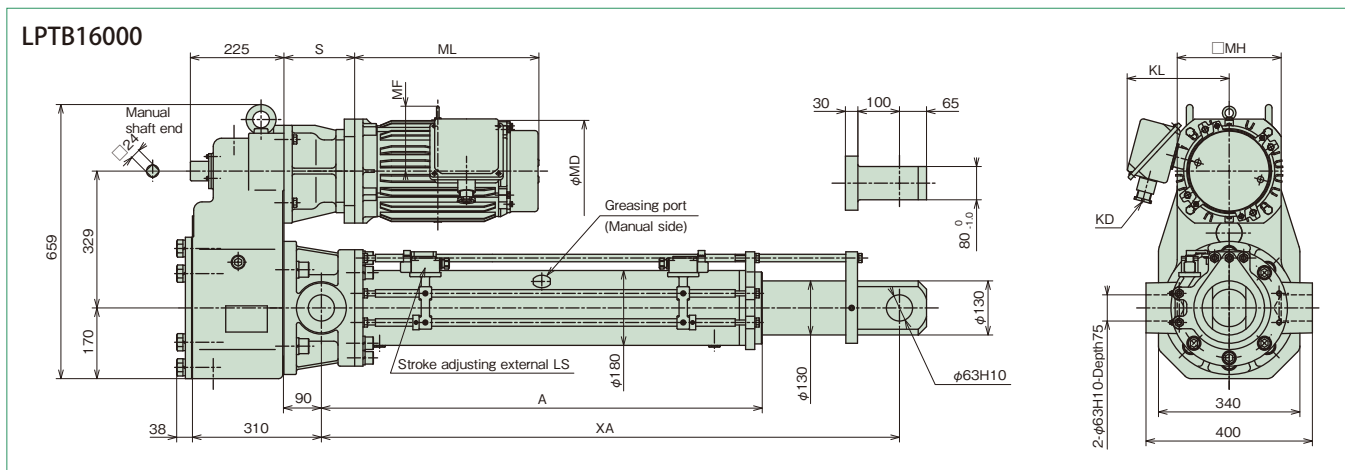

Unit: mm

Model	Nominal speed mm/s 50/60Hz	Motor kW	MD	ML	MF	KL	KD	MH	S
LPTB16000L LPTC16000L	14.5/17.5	3.7	229	414	141	201			145
LPTB16000M LPTC16000M	20/24	5.5	265	403	156	245	A25C	250	170
LPTB16000H LPTC16000H	31/37	7.5	265	441	156	245			170

Approximate mass of main body

Unit: kg

Model	Nominal stroke	500	1000	1500	2000
LPTB16000L		469	525	581	637
LPTC16000L		518	574	630	686
LPTB16000M		480	536	592	648
LPTC16000M		529	585	641	697
LPTB16000H		490	546	602	658
LPTC16000H		539	595	651	707

Unit: mm

Nominal stroke	Thrust		A	XA	
	kN	{ kgf }		MIN	MAX
500	156	16000	1060	1260	1760
1000			1560	1810	2810
1500			2060	2360	3860
2000			2560	2910	4910

1. This diagram shows a power cylinder with an external limit switch for stroke adjustment.
2. Mechanical stroke has a margin of approximately 10mm on both sides for the nominal stroke.
3. For the cylinder with bellows, the stroke will also not change.
4. Use TC type model in brake individual turnoff.
5. When the model of the TC type nominal stroke 2000mm is used, press and stop cannot be carried out near the maximum stroke in terms of buckling strength.
6. For connector part dimensions of the motor terminal box, refer to page 115.

**Options**

■ Bellows ( - J)

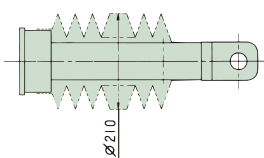

■ Clevis fitting ( - C)

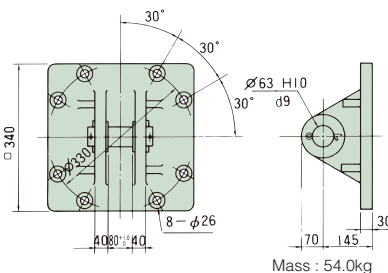

Note) Shipped attached to the main body.  
If it needs to be shipped individually, consult us.

■ Trunnion fitting (LPTB16000-T)

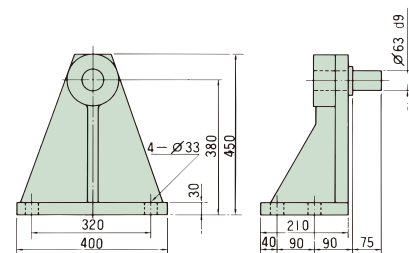

Note) Apply grease to the trunnion pin and trunnion hole before mounting.

\* Dimensions with no tolerance described have general tolerance, and their sizes become larger by approximately 2 to 5mm from the described dimensions. When designing the machine, take the margin into consideration.



# Dimensions Table T Series 32000

## LPTB32000

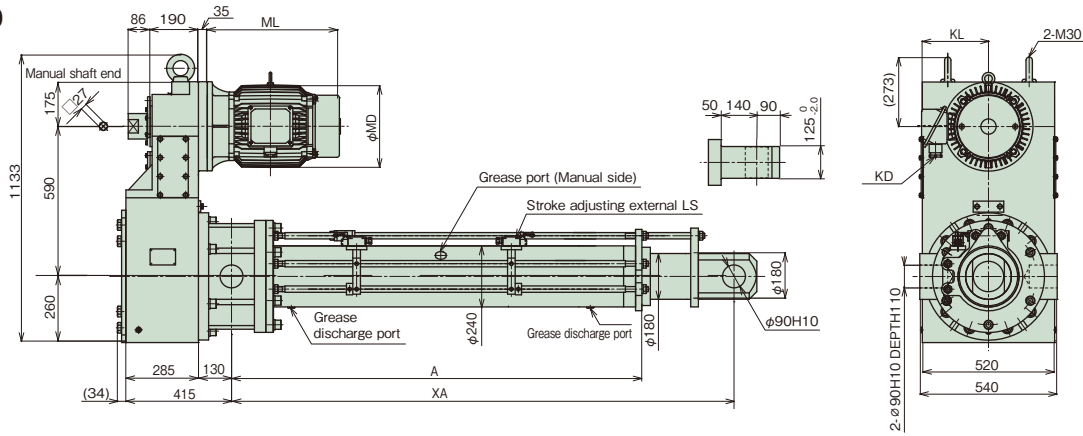

## LPTC32000

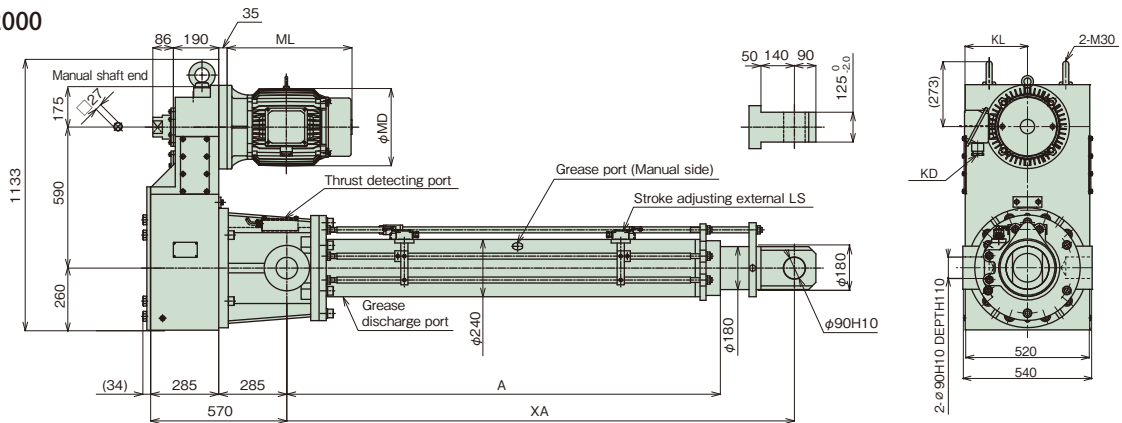

Unit: mm

Model	Thrust		Nominal speed mm/s	Motor kW	MD	ML	KL	KD
	kN	{ kgf }						
LPTB32000L LPTC32000L	313	32000	10/12	5.5	265	403	245	A25C
LPTB32000M LPTC32000M			15/18	7.5	265	441	245	A25C
LPTB32000H LPTC32000H			20/24	11	324	519	263	A30B

Approximate mass of main body

Unit: kg

Model	Nominal stroke	Approximate mass of main body (kg)			
		500	1000	1500	2000
LPTB32000L		1215	1313	1411	1509
LPTC32000L		1305	1403	1501	1599
LPTB32000M		1225	1323	1421	1519
LPTC32000M		1315	1413	1511	1609
LPTB32000H		1294	1392	1490	1588
LPTC32000H		1384	1482	1580	1678

Unit: mm

Nominal stroke	A	XA	
		MIN	MAX
500	1315	1575	2075
1000	1815	2125	3125
1500	2315	2675	4175
2000	2815	3225	5225

1. This diagram shows a power cylinder with an external limit switch for stroke adjustment.
2. Mechanical stroke has a margin of approximately 10mm on both sides for the nominal stroke.
3. For the cylinder with bellows, the stroke will also not change.
4. For connector part dimensions of the motor terminal box, refer to page 115.

## Options

### ■ Bellows ( - J )

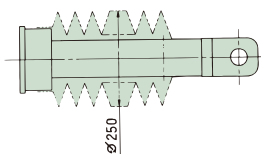

### ■ Clevis fitting ( - C )

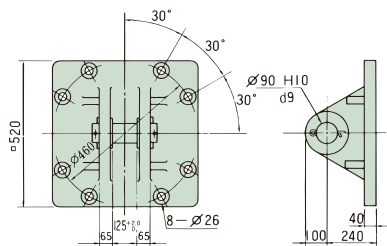

Mass : 185.0kg

Note) Shipped attached to the main body.  
If it needs to be shipped individually, consult us.

### ■ Trunnion fitting (LPTB32000-T)

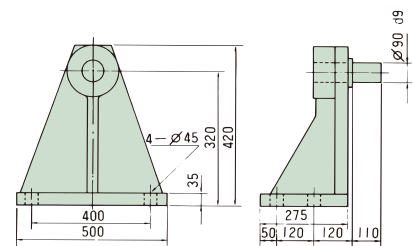

Mass: 149.2kg/set

Note) Apply grease to the trunnion pin and trunnion hole before mounting.

\* Dimensions with no tolerance described have general tolerance, and their sizes become larger by approximately 2 to 5mm from the described dimensions. When designing the machine, take the margin into consideration.

# Position detecting unit

The following three types of position detecting devices can be built in as your requested.

1. Position detecting internal limit switch (with two or four switches)
2. Potentiometer
3. Rotary encoder

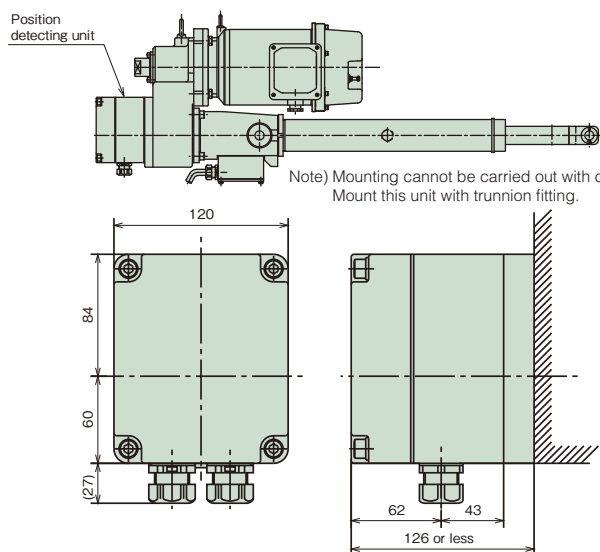

## Internal structure

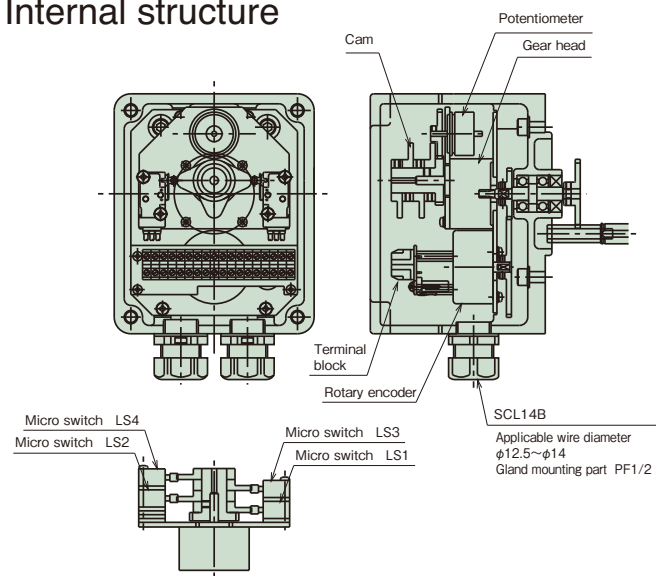

Mass of positional detecting unit Unit: kg

Frame no.	Mass
T500	7.3
T1000	7.6
T2000	8.0
T4000	9.0
T6000	12.2
T8000	13.3
T12000	13.3
T16000	14.5

## 1. Position detecting internal limit switch (with two or four switches)

- With two switches (symbol K2) ..... Layout of micro switches LS<sub>1</sub> and LS<sub>2</sub> in the previous diagram
- With four switches (symbol K4) ..... Layout of micro switches LS<sub>1</sub>, LS<sub>2</sub>, LS<sub>3</sub> and LS<sub>4</sub> in the previous diagram

	Option symbol	Application example	Micro switch specification						
Position detecting internal LS	K2		<table border="1"> <tr> <td>Model</td> <td>D2VW-5L2A-1M (OMRON) Equivalent</td> </tr> <tr> <td>Electric configuration</td> <td>250V AC 4A (cos=0.7)</td> </tr> <tr> <td>Contact configuration</td> <td>1C </td> </tr> </table>	Model	D2VW-5L2A-1M (OMRON) Equivalent	Electric configuration	250V AC 4A (cos=0.7)	Contact configuration	1C 
		Model		D2VW-5L2A-1M (OMRON) Equivalent					
Electric configuration	250V AC 4A (cos=0.7)								
Contact configuration	1C 								
Position detecting internal LS	K4								

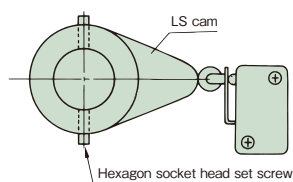

### <Setting of LS>

For adjustment of the operating position, operate the power cylinder to adjust the LS cam. Loosen the hexagon socket head set screws (2 pieces) on the LS cam with a hexagon bar wrench (nominal 1.5).

# Position detecting unit

## 2. Potentiometer

This is a variable resistor to output electric signals depending on the stroke amount of the cylinder. Use this unit in combination with a printed board and a stroke indication meter. Resistance values according to the model have been adjusted before shipment. Separately request preset values according to the model as they are described in the position detecting unit specification drawing. Pay strict attention to handling because correspondence between the stroke position and the resistance value will deviate by rotating the rod of the power cylinder.

Potentiometer specifications	
Model	CP-30 or equivalent
Manufacturer	SAKAE TSUSHIN KOGYO CO., LTD.
Total resistance value	1kΩ
Rated power	0.75W
Dielectric strength	1000V AC 1min.
Effective electric degree	355° ± 5°
Effective mechanical degree	360° endless
Connection	Connected to terminal block in position detecting unit
P1 ← ———— P3 P2 ———— ↑ ← ———— → Cylinder rod retract / extend	

## 3. Rotary encoder

Rotary encoder specifications		
Model	TS5305N251	
Manufacturer	Tamagawa Seiki Co., Ltd.	
Output pulse number	600P/R	
Output waveform	90° phase difference two-phase square wave + home position output	
Output voltage	H	— Note 1)
	L	1V or less Note 1)
Power supply	5~24V DC	

The output signal of the standard specification is of an incremental type, however, an absolute type is also available.

The output type in standard specifications is open collector.

If voltage output type is required, see (Note 1) below.

If the specification of line driver output is required, contact us.

Note 1) Due to the open collector output, output signals are obtained when the pull-up resistor is connected.

Signal 1 and signal 2 are output voltages of H "(power supply voltage - 1)V or more" and L "1V or less."

For the Z-phase, negative logic applies.

<Reference resistance values> 5V: 220Ω, 12V: 470Ω, 24V: 1kΩ

### Output connection

Signal 1	Signal 2	Signal Z	+5V to 24V	0V	Case
(9)	(10)	(11)	(12)	(13)	(14)

Figures in parentheses indicate terminal No.

### Output waveform

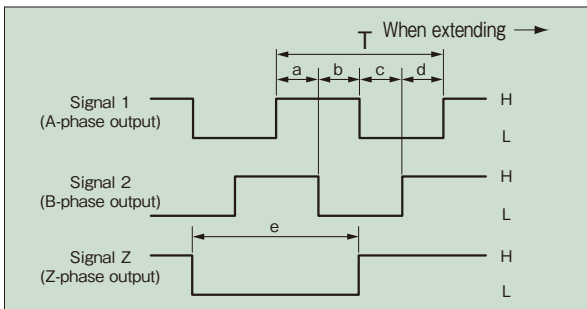

a. b. c. d =  $T/4 \pm T/8$      $T/2 \leq e \leq 3T/2$

### Output circuit

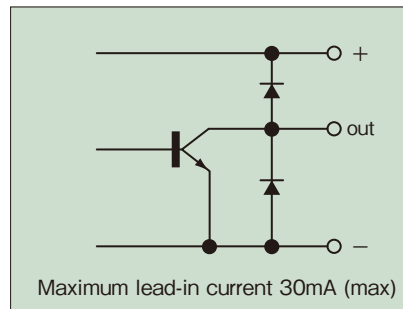

\* Best suited to controlling the stroke by a sequencer or programmable controller, etc.

More accurate positioning control is possible in combination with motor speed control by an inverter, etc.

- ① The standard products incorporate an incremental type encoder.
- ② The rotary encoder has been set to output 10 pulse per stroke of 1mm.
- ③ It is possible to set an accurate home position of the machine in combination with a limit switch because home position output is read out every 600 pulses.
- ④ Do not apply vibration or impact to the rotary encoder because it is precision equipment.
- ⑤ Use shield wire for wiring to the rotary encoder.
- ⑥ As a guide for the distance between the rotary encoder and control panel, a collector current of 20mA should be able to be transmitted approximately 50m (12V pull-up).  
For distances other than the above, consult with us.

# Position detecting unit

## Wire connection in position detecting unit

Use terminals provided in the unit for wire connection to the position detecting internal limit switch, potentiometer and rotary encoder.  
 COM on the internal LS means common use. (internally wire-connected)  
 Use shield wire for wiring to the rotary encoder.

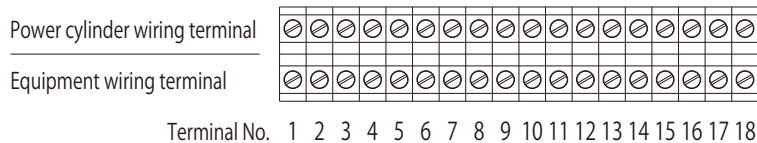

Option	Internal LS (K2, K4)									Potentiometer			Rotary encoder					
Symbol	LS1		LS2		LS3		LS4		Common use	P			R					
Contact	a	b	a	b	a	b	a	b	c	1	2	3	1	2	Z	+5V~24V	0V	Case
Terminal No.	18	17	5	6	16	15	7	8	4	1	2	3	9	10	11	12	13	14

# Control option

## Stroke indication meter

Model	RM-80B(100μA DC) or equivalent
Grade	JIS C 1102 2.5 class
Appearance	Frame•black
Scale specifications	Full stroke indicated by 100%

1. Special scale and wide angle gauge are also available at your request.
  2. When you want to express scale in other than percentage, indicate this to us.
- \* A separate printed board is also required.

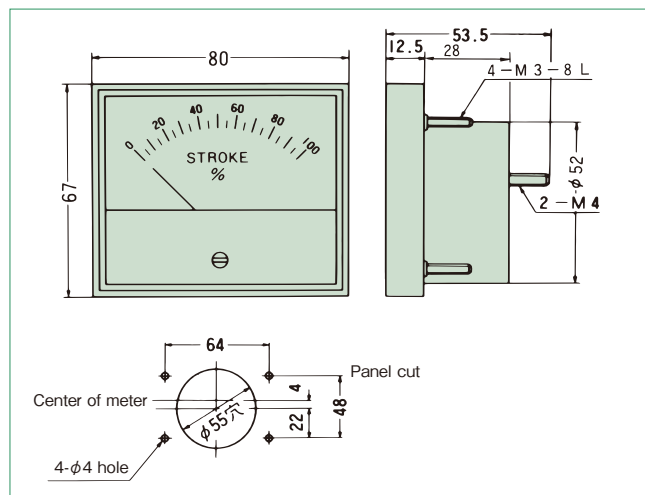

## Printed board

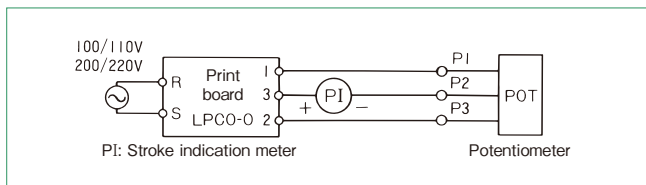

Adjust the meter with an ADJUST volume on the printed board. Do not make a mistake with the stroke indication meter +, -. Replace the terminals 1 and 2 on the print board to set the indication meter to 100% when the stroke is MIN.

Model LPCO-D1 (Operation power source 100/110V 50/60Hz)  
 LPCO-D2 (Operation power source 200/220V 50/60Hz)

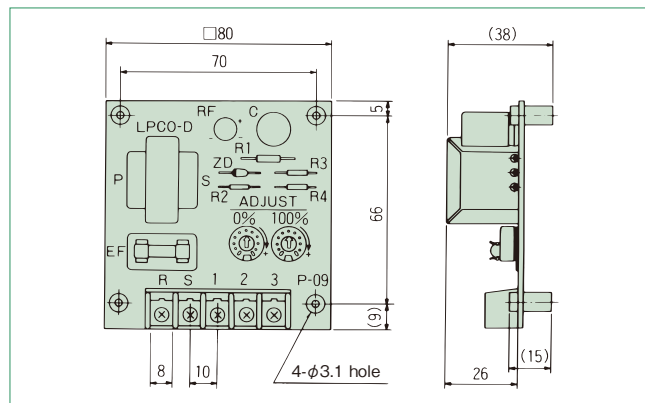

## Control option

### Meter relay

Used for simple adjustment of stroke on the operation panel.

( Iron panel installation is standard. Separately indicate to us when installing an aluminum panel. )

Note) For using 4 – 20mA output, designate as "for 4 – 20mA output."

\* A separate printed board is also required.

Meter relay specifications	
Model number	NRC-100HL (TSURUGA) or equivalent product
Class	JIS C 1102 2.5 class
Appearance	Frame•Black
Scale	Full stroke indicated by 100%
Power source	100/100V AC, 200/220V AC 50/60Hz
Input	100 $\mu$ A DC maximum
Output contact configuration	1C for both HIGH, LOW sides (refer to the following Fig.)
Contact capacity	250V AC 3A ( $\cos \phi = 1$ )

(Described specifications and dimensions may be subject to change due to circumstances.)

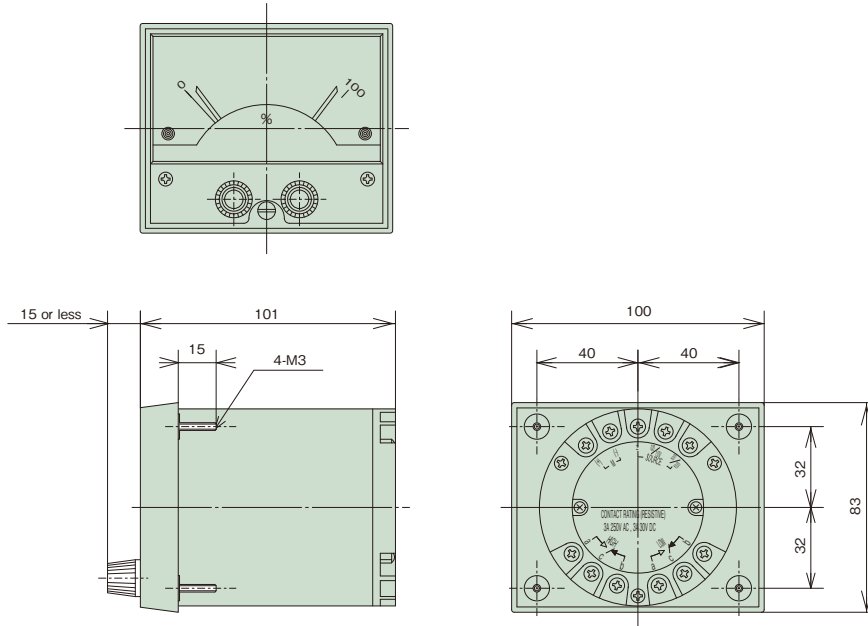

The main body of the power cylinder is provided with a potentiometer.

The phase of a stroke deviates if the rod is rotated before installation. Therefore, cylinders with a stroke adjusting limit switch are recommended.

Pre-set minimum and maximum strokes to be used with the stroke adjusting limit switch, then use the meter relay.

#### <Print board>

This is the same as the print board for the stroke indication meter.

#### <Relay operation> (In the case of b contact)

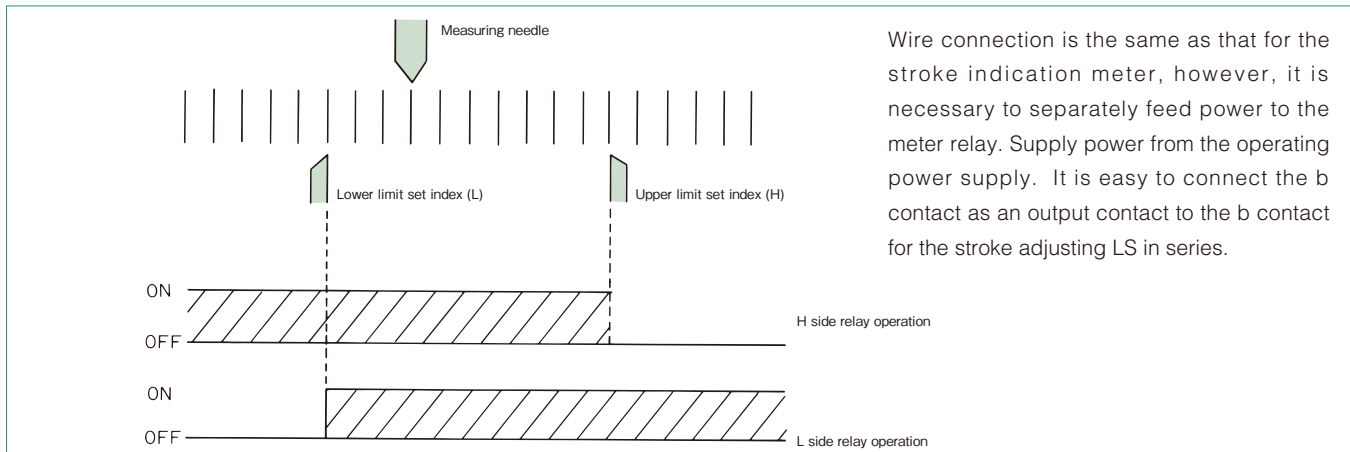

Wire connection is the same as that for the stroke indication meter, however, it is necessary to separately feed power to the meter relay. Supply power from the operating power supply. It is easy to connect the b contact as an output contact to the b contact for the stroke adjusting LS in series.

## Shock relay

Our highly reliable shock relay is recommended as an electric safety device for the power cylinder of the TB type.

For details, refer to the "TSUBAKI E&M electric overload protection devices shock monitor shock relay catalogue."

## Stroke control for power cylinder

There are various methods of positioning control for the power cylinder. Positioning accuracy greatly varies depending on the speed of the power cylinder, the size of the load, the size of a load inertia, the operating direction (vertical, horizontal) and the wire connection method for the brake. Control methods may be limited depending on the operating condition. As such, what methods there are will be conceptually described here.

### Limit switch method

- ① With stroke adjusting limit switch ..... Positioning of stroke upper and lower limit
- ② With position detecting limit switch ..... Intermediate positioning  
Accuracy generally increases with lower cylinder speed.
- ③ Press (pull) stop (Thrust detecting limit switch for T series TC type is used.)

This is a method that stoppers are mechanically provided on both ends of a stroke used for equipment driven by the power cylinder, and press, pull stop are carried out, and then a thrust detecting limit switch for the power cylinder is used. The stroke is mechanically regulated by the stoppers, therefore, accurate positioning is possible.

### Method with potentiometer

This method is convenient when you want to change the stroke of the power cylinder on the control side. Accuracy generally increases as the cylinder speed decreases. For the power cylinder body, the method with a stroke adjusting limit switch is recommended to prevent stroke over.

### Control with meter relay

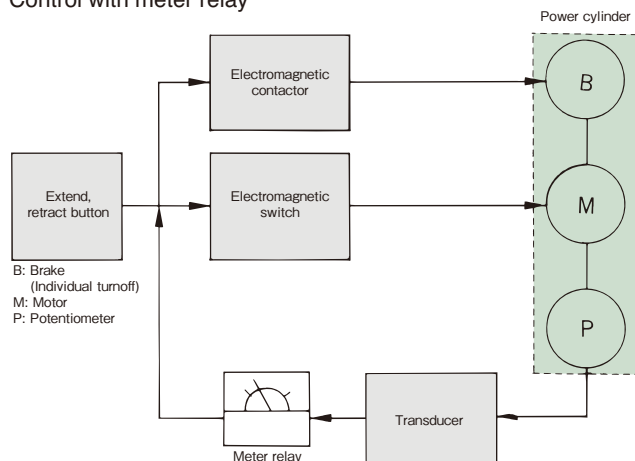

### Method with rotary encoder (RE)

This method controls stroke by a programmable controller (PC). Use the PC with a counter. Use a limit switch to detect home position. (For the power cylinder body, the method with a stroke adjusting limit switch is recommended.)

#### ① Direct control method

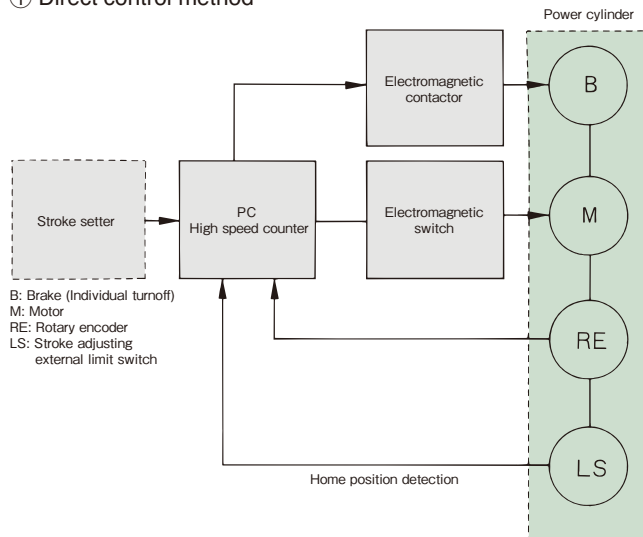

With this method, when OFF signals for the motor and the brake are not simultaneously outputted from the PC, and OFF signal for the motor is outputted earlier, the cylinder coasts while decelerating. Highly accurate positioning is possible because the power cylinder operates at a low speed such as output of an operation signal for the brake just before the stop position.

#### ② Motor speed control method

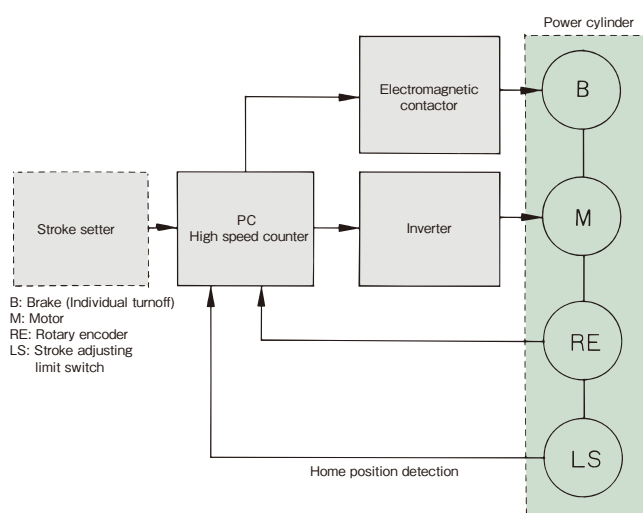

Note that, when a heavy object is moved up or down, or a load with a large inertia is operated, it may not be sufficiently slowed down by any method.



# Wire connection

## Wire connection for brake motor (Motor with DC brake)

In the case of brake internal wiring	
0.1~0.4kW	<div style="display: flex; justify-content: space-around;"> <div style="text-align: center;"> <p>200V class</p> </div> <div style="text-align: center;"> <p>400V class</p> </div> </div>
0.75~3.7kW	<div style="display: flex; justify-content: space-between;"> <div style="text-align: center;"> <p>Common to 200/400V</p> </div> <div style="text-align: center;"> <p>For 5.5kW or higher, use brake external wiring.</p> </div> </div>
In the case of brake external wiring	
0.1~0.4kW	<div style="display: flex; justify-content: space-around;"> <div style="text-align: center;"> <p>200V class</p> <p>200~220V AC</p> </div> <div style="text-align: center;"> <p>400V class</p> <p>200~220V AC</p> </div> </div>
0.75~3.7kW	<div style="display: flex; justify-content: space-around;"> <div style="text-align: center;"> <p>200V class</p> <p>200~230V AC</p> </div> <div style="text-align: center;"> <p>400V class</p> <p>380~460V AC</p> </div> </div>
5.5kW or more	<p>Common to 200/400V</p>
<p><b>Rod operating direction</b></p> <p><small>(In the case of connection on upper surface)</small></p>	<div style="display: flex; justify-content: space-around;"> <div style="text-align: center;"> <p>LPTB<sub>LPTC</sub>250~LPTB<sub>LPTC</sub>16000</p> <p>Rod extend</p> </div> <div style="text-align: center;"> <p>LPTB<sub>LPTC</sub>32000</p> <p>Rod retract</p> </div> </div>

\* Crimp contact bolt: M4

## Wire connection

### ◎ Wire connection method when inverter is used or brake is used in individual turnoff

#### DC brake

- If the motor is operated by the inverter, it is necessary to individually turn off the brake. When individually turning off the brake, as shown in the following diagram, remove the short piece, and do not connect wire to the brake power module from the inverter output, apply a normal power voltage. Separately provide a power supply shown in the following diagram and apply power to the brake power module. If separate power cannot be provided, decrease the voltage by a transformer. Use a transformer whose capacity is more than necessary, and check that there is no voltage drop. And if the motor voltage of 0.1 to 0.4kW is 400V class, also remove the wire from the motor intermediate tap and insulate it.
- If the motor voltage of 0.4kW or less is 400V class, remove the wire from the motor intermediate tap and insulate it, and separately provide a power supply of 200V to 220V and apply power to the brake power module. If there is no power source of 200V to 220V, decrease the voltage to 200V to 220V by a transformer. The capacity of the transformer shall be 90VA or more, and check that there is no voltage drop. Use an electromagnetic contactor for the brake of 200V class with a rated load of 250V AC, 7A or more. For the 400V class, use an electromagnetic contactor with a contact voltage of 400 to 440V AC, an induction load of 1A or more (e.g. electromagnetic contactor for AC motor 2.2kW). The power module includes a surge absorbing protection element. Add a protection element for the contact in each part if necessary.
- Do not put a relay contact on the output side of the standard power module (between the power module and brake coil). When carrying out [DC individual turnoff wiring] in which the relay contact is put into the position, contact us beforehand.

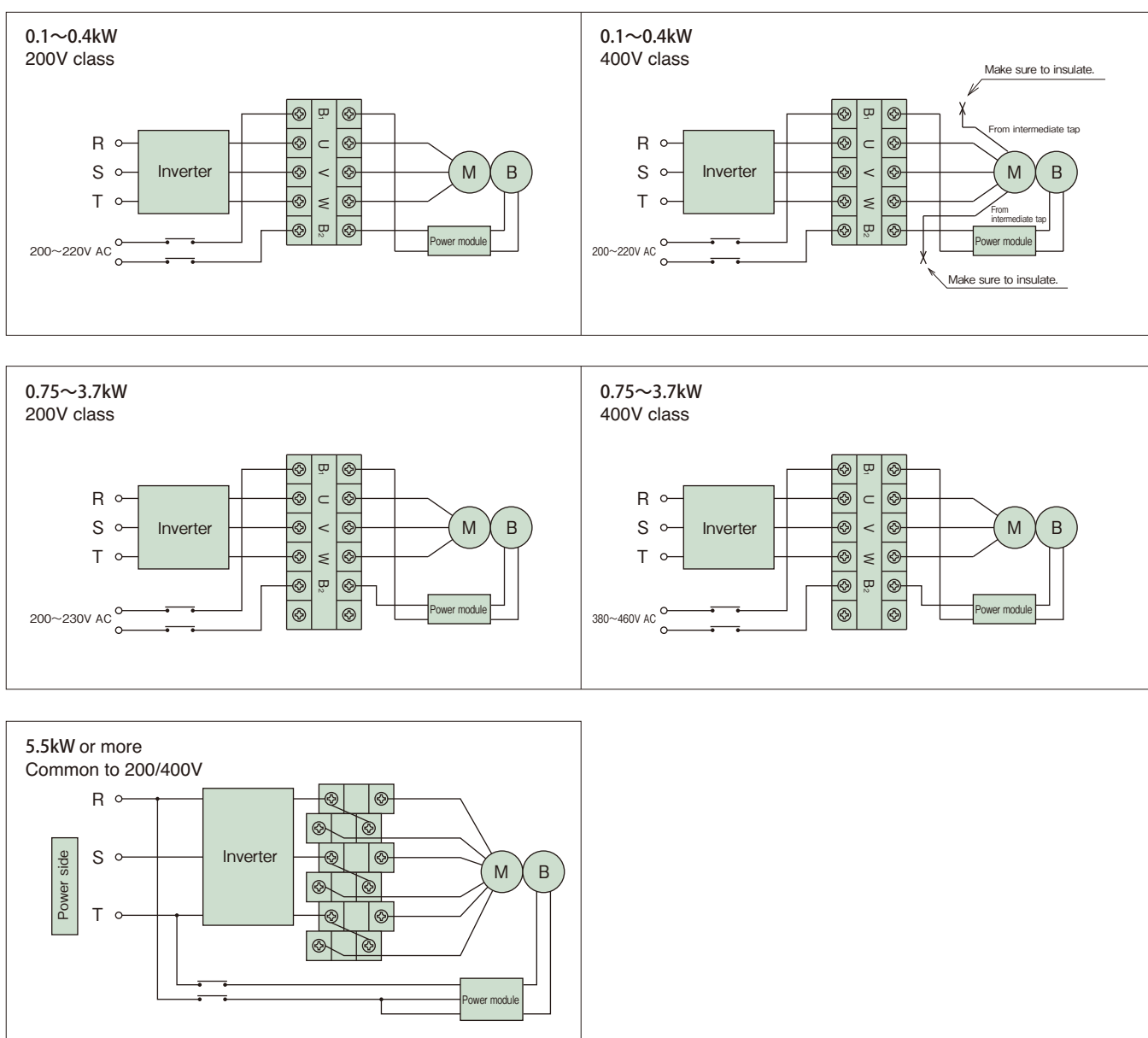

## Wire connection

Dimensions of motor terminal, connector part

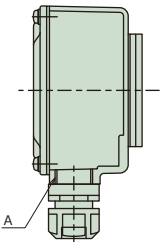
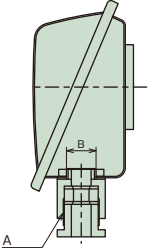
Shape of terminal box	Motor capacity	Shape of connector	Applicable cable outer diameter	Connector part mounting dimension A	Terminal box seat hole dimension B
 (0.4kW or less)	0.1kW~0.4kW	SK-14L	$\phi 11 \sim \phi 13$	PF 1/2	—
 (0.75kW or more)	0.75kW~1.5kW	A20C	$\phi 14 \sim \phi 15$	PF 3/4	$\phi 28$
	2.2kW~7.5kW	A25C	$\phi 19 \sim \phi 20$	PF 1	$\phi 35$
	11kW	A30B	$\phi 23 \sim \phi 24$	PF 1•1/4	$\phi 42$

Note) A rubber plug or plate has been inserted into the connector to prevent water etc., from intruding before shipment.  
Make sure to remove it when using.

## Limit switch specifications

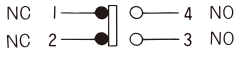
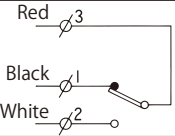
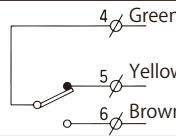
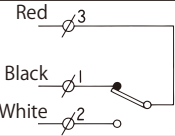
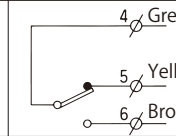
	Stroke adjusting external LS	Thrust detecting LS (LPT16000 or smaller)		Thrust detecting LS	
Limit switch type	WLCA2(OMRON) or equivalent	V-165-1AR5(OMRON) or equivalent		Z-15GW22-B(OMRON) or equivalent	
Electric capacity	250V AC 10A (cos $\phi$ =0.4)	250V AC 10A (cos $\phi$ =0.4)		250V AC 10A (cos $\phi$ =0.4)	
Contact configuration	1a 1b  NC 1 — 4 NO NC 2 — 3 NO	For advancing	For retreating	For advancing	For retreating
		 Red $\phi 3$ Black $\phi 1$ White $\phi 2$	 4 $\phi$ Green 5 Yellow 6 Brown	 Red $\phi 3$ Black $\phi 1$ White $\phi 2$	 4 $\phi$ Green 5 Yellow 6 Brown
Connector (Applicable cable outer diameter)	SCS-10B ( $\phi 8.5 \sim \phi 10.5$ ) PF1/2	SCL-14A ( $\phi 10.5 \sim \phi 12.5$ ) PF1/2		SCS-14A ( $\phi 10.5 \sim \phi 12.5$ ) PF1/2	

## Motor current value • brake current value

Output frame No.	Motor current value (A)						Brake model No.	Brake current value (A)					
	200V 50Hz	200V 60Hz	220V 60Hz	400V 50Hz	400V 60Hz	440V 60Hz		200V 50Hz	200V 60Hz	220V 60Hz	400V 50Hz	400V 60Hz	440V 60Hz
4P - 0.1kW	0.72 (2.76)	0.62 (2.60)	0.65 (2.84)	0.36 (1.38)	0.31 (1.27)	0.32 (1.41)	SBH01LP	0.18 0.27	0.18 0.27	0.19 0.29	0.18 0.27	0.18 0.27	0.19 0.29
4P - 0.2 kW	1.3 (4.91)	1.1 (4.68)	1.1 (5.14)	0.63 (2.40)	0.55 (2.22)	0.56 (2.41)	SBH02LP	0.18 0.27	0.18 0.27	0.19 0.29	0.18 0.27	0.18 0.27	0.19 0.29
4P - 0.4 kW	2.4 (11.6)	2.1 (10.2)	2.1 (11.0)	1.2 (5.14)	1.1 (4.88)	1.1 (5.39)	SBH04LP	0.18 0.27	0.18 0.27	0.19 0.29	0.18 0.27	0.18 0.27	0.19 0.29
4P - 0.75 kW	3.9 (24.0)	3.5 (22.0)	3.4 (24.0)	1.9 (12.0)	1.7 (11.0)	1.7 (12.0)	SLB07LP	0.18 0.27	0.18 0.27	0.20 0.30	0.09 0.15	0.09 0.15	0.10 0.16
4P - 1.5 kW	6.5 (49.0)	6.1 (45.0)	5.8 (50.0)	3.2 (24.5)	3.1 (22.5)	2.9 (25.0)	SLB15LP	0.18 0.29	0.18 0.29	0.20 0.32	0.09 0.15	0.09 0.15	0.11 0.16
4P - 2.2 kW	9.6 (67.0)	9.0 (59.0)	8.6 (64.9)	4.8 (33.5)	4.5 (29.5)	4.3 (32.5)	TB-A2.2	0.25 0.34	0.25 0.34	0.25 0.34	0.13 0.17	0.13 0.17	0.13 0.17
4P - 3.7 kW	15.2 (122)	14.4 (104)	13.6 (114)	7.6 (61.0)	7.2 (51.8)	6.8 (57.0)	TB-A3.7	0.34 0.44	0.34 0.44	0.34 0.44	0.17 0.22	0.17 0.22	0.17 0.22
4P - 5.5 kW	22.4 (146)	21.0 (125)	19.8 (138)	11.2 (73.0)	10.5 (62.5)	9.9 (68.8)	TB-A7.5	1.5 2.0	1.5 2.0	1.5 2.0	3.0 4.0	3.0 4.0	3.0 4.0
4P - 7.5 kW	29.6 (215)	28.2 (185)	26.4 (204)	14.8 (108)	14.1 (92.5)	13.2 (102)	TB-A7.5	1.5 2.0	1.5 2.0	1.5 2.0	3.0 4.0	3.0 4.0	3.0 4.0
4P - 11 kW	42.5 (290)	41.0 (249)	38.0 (274)	21.5 (145)	20.5 (124)	19.0 (137)	TB-A15	1.3 1.7	1.3 1.7	1.3 1.7	2.6 3.4	2.6 3.4	2.6 3.4

Note) 1. The above values are rated current values of the motor and brake. A numerical value in parentheses is a start current value of the motor.

2. The rated current values and start current values do not include a brake current value.

3. A DC brake is used as a brake. The upper stage of the brake current value indicates a value on the primary side of the power module, and the lower stage indicates a value on the secondary side.

4. The above values are references because the rated current values for the power cylinder vary depending on operating conditions.

5. For simultaneous turnoff of 0.1kW to 0.4kW, 400V class, the voltage is converted to 200V through the motor intermediate tap to be input. For individual turnoff, decrease the voltage to 200 to 220V by a transformer. The capacity of the transformer capacity shall be 90VA or more.

6. For individual turnoff of 0.75kW or more, 400V class, the DC module is applicable for 400V class, therefore, it is unnecessary to decrease the voltage.

7. For 0.75kW and 1.5kW of 400V class, the brake model Nos. are "SLB07LPV" and "SLB15LPV," respectively.

Reference circuit

0.75 to 3.7kW TC type reference circuit diagram

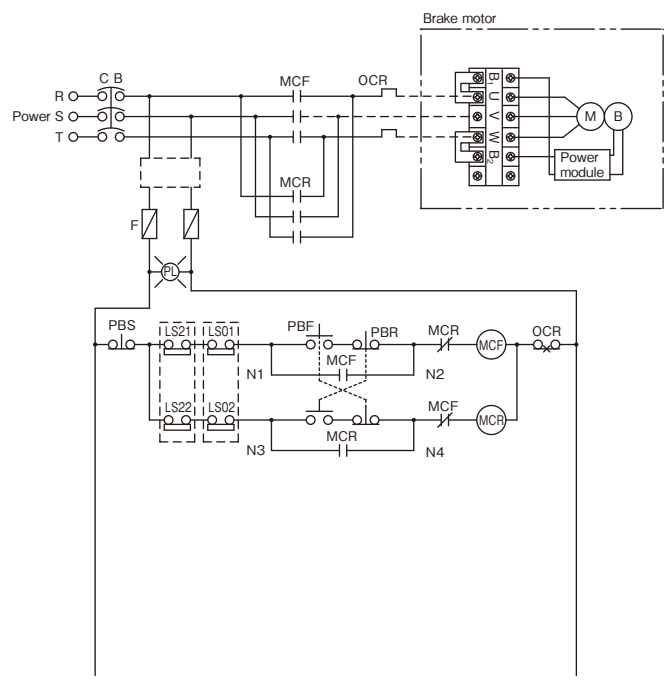

- LS01: Stroke adjusting external limit switch for extending
- LS21: Thrust detecting limit switch for extending
- LS02: Stroke adjusting external limit switch for retracting
- LS22: Thrust detecting limit switch for retracting

**NOTE :**

- (1) This diagram is an example when the thrust detecting limit switch is used for overload protection.
- (2) This diagram shows a single-acting circuit. When using in an inching circuit, remove wire connection between N1 and N2, N3 and N4 and short-circuit the PBS.
- (3) If the power source voltage for the motor is different from the control voltage, place a transformer into a [ ] portion in the diagram.
- (4) The lead wires B1 and B2 for the brake are connected to the motor terminal blocks U and W using short pieces.
- (5) When individually turning off the brake, remove the short piece and apply a normal power source voltage other than inverter output to B1 and B2 from the outside.

0.75 to 3.7kW Brake individual turnoff two units multiple reference circuit diagram

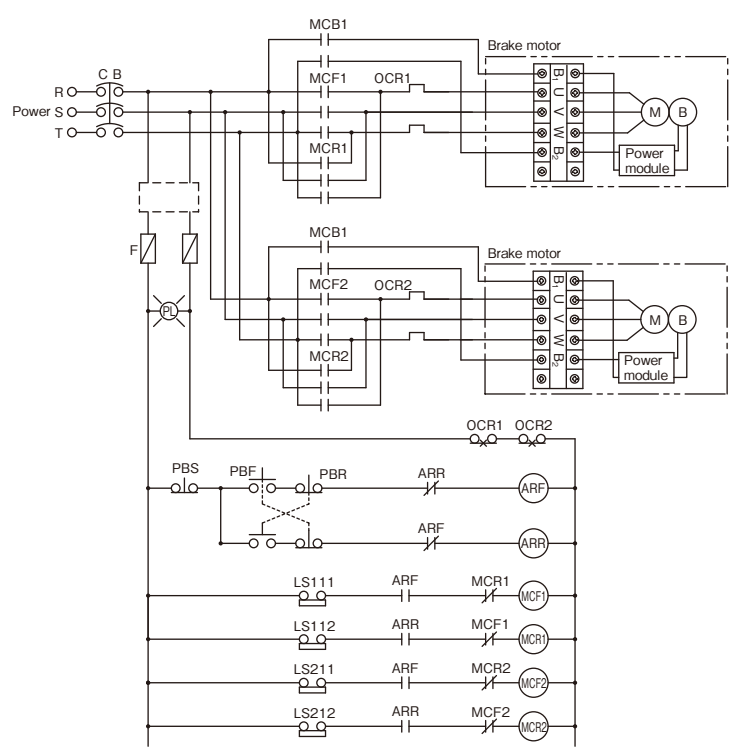

- LS111: LPNo.1 Stroke adjusting external limit switch for extending LS1
- LS112: LPNo.1 Stroke adjusting external limit switch for retracting LS1
- LS211: LPNo.2 Stroke adjusting external limit switch for extending LS2
- LS212: LPNo.2 Stroke adjusting external limit switch for retracting LS2

**NOTE :**

- (1) This diagram is an example of 0.75kW or more brake individual turnoff two units inching multiple circuit.
- (2) If the power source voltage for the motor is different from the control voltage, place a transformer into a [ ] portion in the diagram.
- (3) As the brake terminal blocks B1 and B2 are connected to the motor terminal blocks U and W using short pieces, remove the short pieces before use.
- (4) Apply a normal power source voltage other than inverter output to B1 and B2 from the outside.

\* For reference circuit for the type of 0.4kW or less, refer to page 80.

## Installation

### Installation direction

Any of horizontal, vertical and inclined direction is allowed.

### Installation method

For installation of the main body, use a trunnion mount or clevis mount (parallel only).

Apply grease to the trunnion pin and the bracket hole before mounting.

Install the end part with a U-type or I -type end fitting.

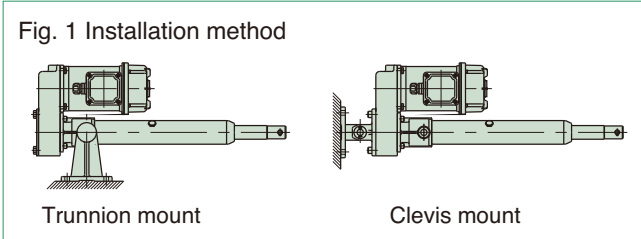

\* For the mount fitting, refer to the item of options.

### Manual operation

When manually adjusting the stroke, rotate the manual handle shaft on the reducer part with a monkey wrench or a socket wrench after releasing the brake for the brake motor.

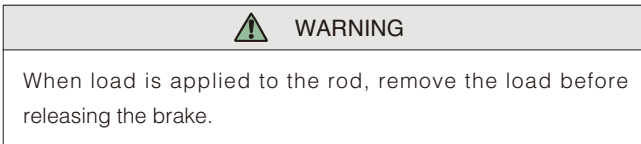

For the amount of movement of the rod per one turn of the manual shaft, refer to the standard model list (page 87).

### Anti-rod rotation

1. Anti-rod rotation is required because a rotating force is generated on the rod with thrust (refer to page 87). Generally, rotation can be mostly prevented by installing the rod end to a driven machine.
2. When operating with the end set free or in the case of application to install pulleys to pull a rope, a rod anti-rotation is normally required.

### Lateral load on rod

Install the power cylinder so as to prevent bending load (lateral load) from acting on the rod.

### Setting of stroke adjusting external LS

- Take a coasting amount into consideration for adjustment of the limit switch.
- When using the cylinder at the nominal stroke 100%, set the limit switch so that the cylinder stops within the XA dimension in the Dimensions Table.
- When simultaneously operating two or more power cylinders, install a limit switch at the upper limit and lower limit on each cylinder.

## Maintenance

### Lubrication on ball screw

Use the ball screw as it is because it has been lubricated with grease in advance. Refill grease with reference to Table 1-2 as a guide. To apply grease to the ball screw, remove the greasing port bolt on the outer cylinder and advance the rod in the full stroke and apply grease to the outer circumference of the screw with a grease gun, and then reciprocate the rod within the stroke to be used. Repeat this operation a few times.

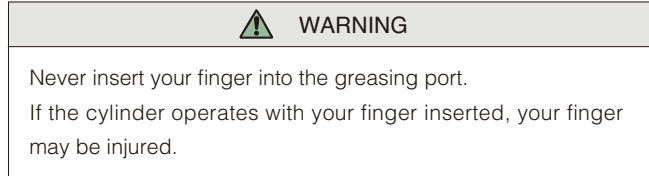

Table 1 Recommended grease

Use classification	Company name	Grease name
Screw shaft	TSUBAKI E&M	JWGS100G
	IDEMITSU KOSAN	*DAPHNE EPONEX SRNo.2
	NIPPON GREASE	NIGULUBE EP-2K
	EXXON MOBILE	MOBILUX EPNo.2
	COSMO OIL LUBRICANTS	COSMO GREASE DINAMX EPNo.2
	SHOWA SHELL	SHELL ALBANIA EP grease 2

\* The above greases are filled before shipment.  
Note) JWGS100G is separately sold in a container of 100g.

Table 2 Lubrication cycle

Operating frequency	Lubrication cycle
500 to 1000 times/day	Three to six months
100 to 500 times/day	Six months to one year
10 to 100 times/day	One to one and half year

Note) The above values are for longer use, and do not indicate the life.

### Greasing on Reduction part

For the gear and the bearing in the reducer part, the gear case is filled with grease. Accordingly, it is not necessary to grease because they normally endure use for one year or longer. However, operation for a long time or use after long storage impairs the lubrication effect due to deterioration of grease. Therefore, inspect and grease.

Reducer part initial filled grease

Gear case: DAPHNE EPONEX SRNo.1 IDEMITSU KOSAN  
Planetary gear (straight type): Moly gear grease No. 1 SUMICO LUBRICANT CO., LTD.

### Gap adjustment of brake

Although the electromagnet stroke (gap) of the brake has been adjusted to approximately 1.2 through 1.3mm (limit gap 1.5mm) for 0.4kW or less or to approximately 0.2mm (limit gap 0.5mm) for 0.75kW or more, re-adjust it before it exceeds the limit gap value.

**For details, refer to the Operation Manual.**

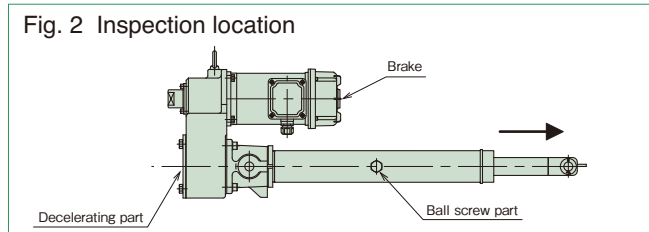

# **WARNING**

## ■ Cautions for selecting

- Anti-rod rotation is required because a rotating force is exerted on the rod with thrust. Rod rotating forces at the rated thrust are described in the model list. When operating with the end unconnected or when installing pulleys to pull rope, use an optional rod anti-rotation specification.
- When the cylinder operating stroke is short, a high speed type cylinder cannot be used because the operating time per one stroke becomes shorter and cannot be actually controlled. The following table shows minimum necessary strokes when motor energization time is 0.5s. Refer to this table to determine the speed.

<b>Speed symbol</b>	H
<b>Nominal speed mm/s 50/60Hz</b>	100/120
<b>0.5s operation moving amount mm</b>	50/60
<b>Predicted maximum coasting amount mm (Reference)</b>	24/33
<b>Minimum necessary stroke mm</b>	74/93 or more

## ■ Cautions for installation

- Apply grease to the trunnion pin and the trunnion hole for trunnion mounting.
- Also, apply grease to the connecting pin of the end fitting and the connecting pin for clevis mounting.
- When the main body greatly swings by operation of the cylinder, consider using a sliding bearing or a rolling bearing for the connecting part. Cylinders whose trunnion hole is provided with sliding bearing are available as MTO.
- When the trunnion pin or connecting pin for the clevis or the end fitting is directed in the vertical direction (when the cylinder is laid horizontally), and the main body swings, take countermeasures for wear such as inserting a bearing member into the trunnion hole, the clevis fitting, or the side part of the end fitting.
- All models are totally enclosed structures so that they can be used normally outdoors, however, under adverse conditions exposed to constant water and steam etc., and snow accumulation, although they are an outdoors type, an appropriate cover is required. The power cylinder can generally be used in a range of -15°C to 40°C, although it varies depending on the use conditions. When using at 40°C or higher, always protect with a heat insulating cover, etc. Never use in a flammable atmosphere, otherwise it may cause an explosion and fire. In addition, avoid using it in a location where vibration or shock exceeding 1G is applied.
- When using a cylinder of the cabtire cable lead wire specification outdoors, carry out waterproofing treatment sufficiently.

## ■ Cautions for use

- Regulate the both ends of the stroke by the limit switch. Select a type of option which allows the limit switch to be mounted on the power cylinder body.
- Use within the stroke range. If the stroke is exceeded, breakage may occur.
- As a high-speed type (H speed) of the power cylinder T series has a long coasting distance, the striker may override the limit switch. For this reason, make sure to allow a limit signal to be self-held on the control circuit.
- Megger testing is prohibited for this cylinder. It may break the built-in power module. Remove the brake wiring for the terminal block when conducting megger testing of the external circuits.
- Adjustment of the limit switch for thrust detection of the TC type must not be carried out by the customer. The preset value for thrust detection may greatly change.



## Power Cylinder Scum Skimmer Specifications



### 6 features

- 1 Easy maintenance**  
In comparison with a hydraulic and pneumatic type, troublesome oil replacement and drain check are not necessary, and maintenance is easy.
- 2 Simple structure of equipment and low cost**  
Neither hydraulic unit, compressor nor piping are necessary, allowing for cost reductions throughout the whole facility.
- 3 Environmentally friendly**  
Totally closed outdoor type brake motor and many stainless parts are used, and coating suitable for water treatment facility is applied.
- 4 Wide variety of options**  
A wide variety of options such as potentiometer, bellows and opening meter are available.
- 5 An abundance of results**  
Nationwide in Japan more than one hundred water treatment plants have adopted this power cylinder.
- 6 Energy savings**  
Adoption of highly efficient ball screw allows the motor capacity to be smaller in comparison with trapezoidal screw specifications.

### Four points for more user-friendliness

- 1. Workability increased by making position detecting unit large.**  
Workability has remarkably increased by sizing up the position detecting unit by 2.5 times in volume ratio in comparison with the conventional one, and structuring the unit so that there is no obstacle around the LS cam and the terminal block when the cover is removed.
- 2. Centralizing terminals for all control systems on one terminal block**  
Wiring work is facilitated by centralizing terminals for the optional potentiometer in addition to the internal limit switch, thrust detecting limit switch and manual interlock limit switch on one terminal block in the position detecting unit.
- 3. Wiring with PLICA tube**  
The position detecting part and thrust detecting part can be respectively equipped with a waterproof union box connector (SANKEI MANUFACTURING Co., Ltd: WBG-24, WBG-17) for PLICA tube. PLICA tube and waterproof union box connector should be provided by the customer. However, the motor terminal box is equipped with the WBG-17 as standard.
- 4. Others**
  - Adherence of rust decreased by press-fitting a bushing into the trunnion hole of the bracket. (When installing, apply grease to the trunnion pin and in the trunnion hole.)
  - The greasing port bolt and manual interlock cap are connected to the main body with a stainless steel ball chain, preventing them from falling.

## Power cylinder G series, T series Right Angle Specifications

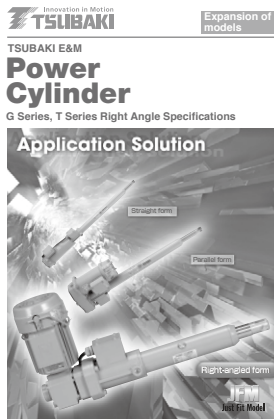

### What right angle specification is

This is a form so that the motor part is right-angled (perpendicular) to the actuating part of the power cylinder. This specification responds to a wide range of needs by adopting our small size gear motor (worm gear) on the motor part.

### Right Angle Specification 6 Features

- 1 Low speed**  
Applicable to lower speeds even lower than the standard speed of the power cylinder G series and T series.  
**Motor capacity can be smaller.**
- 2 Low noise**  
Noise level can be reduced by approximately 25dB in comparison with conventional products. (compared with our ordinary products)  
Noise reference value (Our measured value) 45dB (at 1m in A scale)  
**This can be used in applications such as concert halls and medical facilities which require low noise.**
- 3 Fall-preventing mechanism**  
Three fall-preventing mechanisms can be simultaneously made applicable by providing a self-lock system of the trapezoidal screw and the worm gear and providing a brake on the motor part.  
**This mechanism can be used in applications such as medical equipment for which falling may be problematic.**
- 4 Wide variety of options**  
A wide variety of options such as an inverter motor and one touch manual release, including without brake and with brake are available.  
**This can be used across a wide range of applications.**
- 5 Space savings**  
Longitudinal dimensions are shortened by up to approximately 180mm in comparison with conventional products. (LPG series)  
The motor part can be rotated every 90 degrees to the operating part.  
**This can be used in applications such as compactly designed equipment.**
- 6 Global measures**  
Power cylinders conforming to worldwide directives, standards and organizations (such as CCC, CE, UL) are available.  
**This power cylinder can be used for equipment to be exported abroad.**

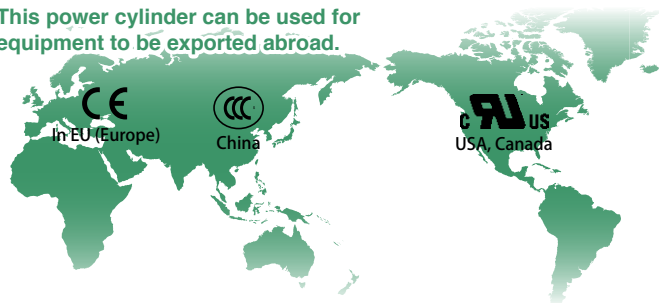



### Further evolution in the strength of "TSUBAKI" motors!

The available range of special brake motors for power cylinders has been expanded to 1.5kW.

Our lineup has been strengthened!!

## Six specifications of brake motor upgrades

### 1 Heat resistance specification: T

Compared with conventional products, substantial reductions in delivery time and price reduction have been realized. Also, heat resistance class “H”, which would conventionally be unavailable, can be met.

- <Common specifications>
- Adaptable models: G series and T series of power cylinders
  - Adaptable motor capacity: 0.1kW – 1.5kW
  - Totally outdoor type (IP55) with brake (The heat resistance class of the brake is B.)

#### Heat resistance class “F” supported Reference delivery time 30 days

##### 40°C

- Model No.: T1 (200V class), VT1 (400V class), V1T1 (380V, 50Hz), V2T1 (380V, 60Hz), V3T1 (415V, 50Hz), V4T1 (460V, 60Hz)  
Usable temperature range: 0 – 40°C (non-condensing)  
Duty factor: 25%ED  
Rating: S2 30min.  
Brake power supply module: Built into the terminal box

##### 60°C

- Model No.: T2 (200V class), VT2 (400V class), V1T2 (380V, 50Hz), V2T2 (380V, 60Hz), V3T2 (415V, 50Hz), V4T2 (460V, 60Hz)  
Usable temperature range: 0 – 60°C (non-condensing)  
Duty factor: 15%ED  
Rating: S2 15min.  
Brake power supply module: Separate placement (standard DC module) \* Install in a 40°C or lower environment.  
\* If being built into the terminal box is desired, contact us.

##### 80°C

- Model No.: T3 (200V class), VT3 (400V class), V1T3 (380V, 50Hz), V2T3 (380V, 60Hz), V3T3 (415V, 50Hz), V4T3 (460V, 60Hz)  
Usable temperature range: 0 – 80°C (non-condensing)  
Duty factor: 5%ED  
Rating: S2 5min.  
Brake power supply module: Separate placement (standard DC module) \* Install in a 40°C or lower environment.  
\* If being built into the terminal box is desired, contact us.

#### Heat resistance class “H” supported Reference delivery time 60 days

- Model No.: T4 (200V class), VT4 (400V class), V1T4 (380V, 50Hz), V2T4 (380V, 60Hz), V3T4 (415V, 50Hz), V4T4 (460V, 60Hz)  
Usable temperature range: 0 – 80°C (non-condensing) \* We will confirm the duty factor and rating in each case.  
Duty factor: 15%ED  
Rating: S2 15min.  
Brake power supply module: Separate placement (special DC module) \* Install in a 40°C or lower environment.  
\* The motor terminal is a lug type.

## 2 Different voltage specification: V

We will deliver conventionally-available different voltage motors in a short period of time. Also, an estimation request and arrangements can be made smoothly through model-numbering of each voltage.

- <Common specifications>
- Adaptable models: G series and T series of power cylinders
  - Adaptable motor capacity: 0.1kW – 1.5kW
  - Totally outdoor type (IP55) with brake
  - Heat resistance class B

### Different voltage supported Reference delivery time + one week

- Model No.: V1 (380V, 50Hz), V2 (380V, 60Hz), V3 (415V, 50Hz), V4 (460V, 60Hz)  
Usable temperature range: -15 – 40°C (non-condensing)  
Duty factor: 25%ED  
Rating: S2 30min.  
Brake power supply module: Built into the terminal box
- Note
  - For using the brakes by external wiring, contact us.

## 3 Inverter specification: Z

Compared with conventional products, substantial reduction in delivery time and price reduction have been realized. The controllability of power cylinders has been improved as speed control including acceleration and deceleration and speed variations can be performed easily. Also, outdoor type with brake is standard.

- <Common specifications>
- Adaptable models: G series and T series of power cylinders
  - Adaptable motor capacity: 0.1kW – 1.5kW
  - Totally outdoor type (IP55) with brake (The heat resistance class of the brake is B.)
  - Heat resistance class F
  - Constant torque operation can be performed in the range of 6 – 60Hz.

### Inverter drive supported Reference delivery time 30 days

- Model No.: Z (200V class), ZV (400V class)  
Usable temperature range: 0 – 40°C (non-condensing)  
Duty factor: 25%ED  
Rating: S2 30min.  
Brake power supply module: Built into the terminal box
- \* Apply not inverter output but normal power supply voltage to the brake power supply module.  
Applicable power supply voltage is 200 – 220V for 200V class and 400 – 440V for 400V class.

## 4 Global specification: N

Power cylinders conforming to worldwide directives, standards and systems (CE, UL and CCC) are available. They can be used for equipment to be exported abroad.

- <Common specifications>
- Adaptable models: G series and T series of power cylinders
  - Adaptable motor capacity: 0.1kW – 0.4kW
  - Usable temperature range: -15 – 40°C (non-condensing)
  - Totally indoor type with brake
- Note
- Only brake motors are compliant with the standards. If limit switches, etc., are required, contact us.

### CE-compliant Reference delivery time 60 days

- Model No.: Z (200V class), VN (400V class)
- Specifications (both N and VN)  
Protection class: IP20  
Heat resistance class: B



Target directive and standard  
Target directive: Low Voltage Directive 73/23/EEC  
Target standard: EN60034-1 (general motor regulations)

Products to be exported to the European market must be CE-marked to prove conformity with safety requirements provided by EC Directives. (Being “CE-compliant” is to affix a “CE mark” to products to prove conformity with EC Directives.)

### UL-compliant Reference delivery time 60 days

- Model No.: N2 (230/240V, 60/60Hz), VN2 (460V, 60Hz)
- Specifications (both N2 and VN2)  
Protection class: IP20  
Heat resistance class: A



Target standard and file No.  
Target standard: UL1004  
UL file No.: E225995

UL is an abbreviation for “Underwriters Laboratories” which represents safety standards for testing in the U.S. (Being “UL-compliant” is to affix a “UL mark” to products to prove UL standard certification with use of UL-standard-accredited motors.) Our certification in C-UR model conforms with both UL and CSA standards.

### CCC-compliant Reference delivery time 60 days

- Model No.: N3 (200/220/200/220V, 50/50 60/60Hz)  
\* Only 200/220V, 50/60Hz for 0.4kW.  
VN3 (380V/50Hz)
- Specifications (both N3 and VN3)  
Protection class: IP23  
Heat resistance class: E



National standard: GB12350

CCC is the China Compulsory Certification system, and for exporting 1.1kW or smaller motors to China, it is necessary to indicate a “CCC mark” to prove compulsory certification. We have received certification from the CQC (China Quality Certification Center).

### Explosion-proof specification: D

Power cylinders adaptable to explosion-proof structures, which can be used in class 1 and class 2 hazardous locations, can be delivered in a short period of time. A vessel having an explosion-proof structure withstands the pressure of an explosion of explosive gas, if caused inside the vessel, and poses no danger of catching fire with external explosive gas.

**<Common specifications>**

- Adaptable models: G series and T series of power cylinders
- Adaptable motor capacity: 0.2kW – 1.5kW
- Totally outdoor type (IP44) with brake
- Heat resistance class B

**■Note**

- Inverters cannot be used.
- Stroke adjusting external limit switches are available. Contact us.
- LPTC (thrust detection mechanism type) and the position detecting unit part cannot be explosion-proof.
- Brakes cannot be used by external wiring.

**d2G4-compliant**

**Reference delivery time 30 days**

■Model No.: D (200V class), VD (400V class)

Usable temperature range: -10 – 40°C (non-condensing)

Duty factor: 25%ED

Rating: S3 40%.

Brake power supply module: None (AC brake)

### Adapter specification: A

To be prepared for customer-desired manufacturer, IEC, NEMA, overseas standards, and other special flange motors, adapters are available from us to facilitate installation. Also, they are available for other special flange sizes and motor shaft diameters. Contact us.

**<Common specifications>**

- Adaptable models: T series of power cylinders
- Adaptable motor capacity: 0.1kW – 7.5kW

**Adapter supported**

■Model No.: A (adaptable to all brake motors)

■Standards use environment of power cylinder

Usable temperature range: -15 to 40°C (non-condensing) \*40°C or higher is also supported.

Duty factor: Within 25%ED

**■Note**

- The brake motor starting torque should be 200% or more of the rated torque.
- Make sure to prepare power cylinders with brakes because they are highly efficient.
- The brake torque should be 150% or more of the rated torque.

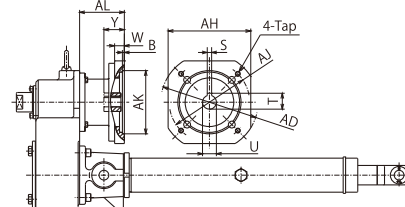

**T series adapter interconnection dimensions list (IEC standard motor)**

Unit: mm

Model No.	Speed	Motor capacity	Frame No.	AL	AD	AH	AK	B	AJ	S	T	U	W	Y	Tap dia.				
LPTB LPTC	250	S	0.1	63	80	φ160	—	φ110G7	4	φ130	4Js9	12.8	φ11F7	15	25	4-M8			
		L	0.1		72		—		5		5Js9	16.3		φ14F7			14	32	
		M	0.2	71	72		—		φ130	4	φ165	6Js9	21.8	φ19F7	20		42	4-M10	
		H	0.4				92					φ200	□170	φ130H7	4		φ130		4Js9
LPTB LPTC	500	S	0.1	63	80	φ160	—	φ110G7	4	φ130	4Js9	12.8	φ11F7	15	25	4-M8			
		L	0.2		72		—		5		5Js9	16.3		φ14F7			14	32	
		M	0.4	71	72		—		φ130	4	φ165	6Js9	21.8	φ19F7	20		42	4-M10	
		H	0.75				80					φ200	□170	φ130H7	4		φ165		8Js9
LPTB LPTC	1000	S	0.2	63	80	φ160	—	φ110G7	4	φ130	4Js9	12.8	φ11F7	15	25	4-M8			
		L	0.4	71	72		—		5		5Js9	16.3		φ14F7			14	32	
		M	0.75	80	92		φ200		□170	φ130H7	4	φ165	6Js9	21.8	φ19F7		20	42	4-M10
		H	1.5	90L	92		φ200		□170	φ130H7	4	φ165	8Js9	27.3	φ24F7		20	52	
LPTB LPTC	2000	S	0.4	71	85	φ160	—	φ110G7	4	φ130	5Js9	16.3	φ14F7	15	32	4-M8			
		L	0.75	80	72		φ200		—		φ130G7	5		φ165			6Js9	21.8	φ19F7
		M	1.5	90L	72		φ200		—	φ130G7	5	φ165	8Js9	27.3	φ24F7		16	52	4-M10
		H	2.2	100L	116		φ250		□200	φ180H7	4.5	φ215	8Js9	31.3	φ28F7		20	62	
LPTB LPTC	4000	S	0.75	80	90	φ200	—	φ130G7	4	φ165	6Js9	21.8	φ19F7	20	42	4-M10			
		L	1.5	90L	72		φ200		—		φ130G7	5		φ165			8Js9	27.3	φ24F7
		M	2.2	100L	116		φ250		□200	φ180H7	4.5	φ215	8Js9	31.3	φ28F7		20	62	4-M12
		H	3.7	112M	116		φ250		□200	φ180H7	4.5	φ215	8Js9	31.3	φ28F7		20	62	
LPTB LPTC	6000	S	0.75	80	90	φ200	—	φ130G7	4	φ165	6Js9	21.8	φ19F7	20	42	4-M10			
		L	1.5	90L	72		φ200		—		φ130G7	5		φ165			8Js9	27.3	φ24F7
		M	2.2	100L	116		φ250		□200	φ180H7	4.5	φ215	8Js9	31.3	φ28F7		20	62	4-M12
		H	3.7	112M	116		φ250		□200	φ180H7	4.5	φ215	8Js9	31.3	φ28F7		20	62	
LPTB LPTC	8000	S	1.5	90L	137	φ200	—	φ130G7	4	φ165	8Js9	27.3	φ24F7	12	52	4-M10			
		L	2.2	100L	96		φ250		—			φ180G7		5			φ215	8Js9	31.3
		M	3.7	112M	96		φ250		□200	φ180G7	5	φ215	8Js9	31.3	φ28F7		20	62	4-M12
		H	5.5	132S	121		φ300		□250	φ230H7	5	φ265	10Js9	41.3	φ38F7		45	82	
LPTB LPTC	12000	L	2.2	100L	145	φ250	□200	φ180G7	5	φ215	8Js9	31.3	φ28F7	20	62	4-M12			
		M	3.7	112M															
		H	5.5	132S															
LPTB LPTC	16000	L	3.7	112M	145	φ250	□200	φ180G7	5	φ215	8Js9	31.3	φ28F7	20	62	4-M12			
		M	5.5	132S															
		H	7.5	132M															

# Model No. designation

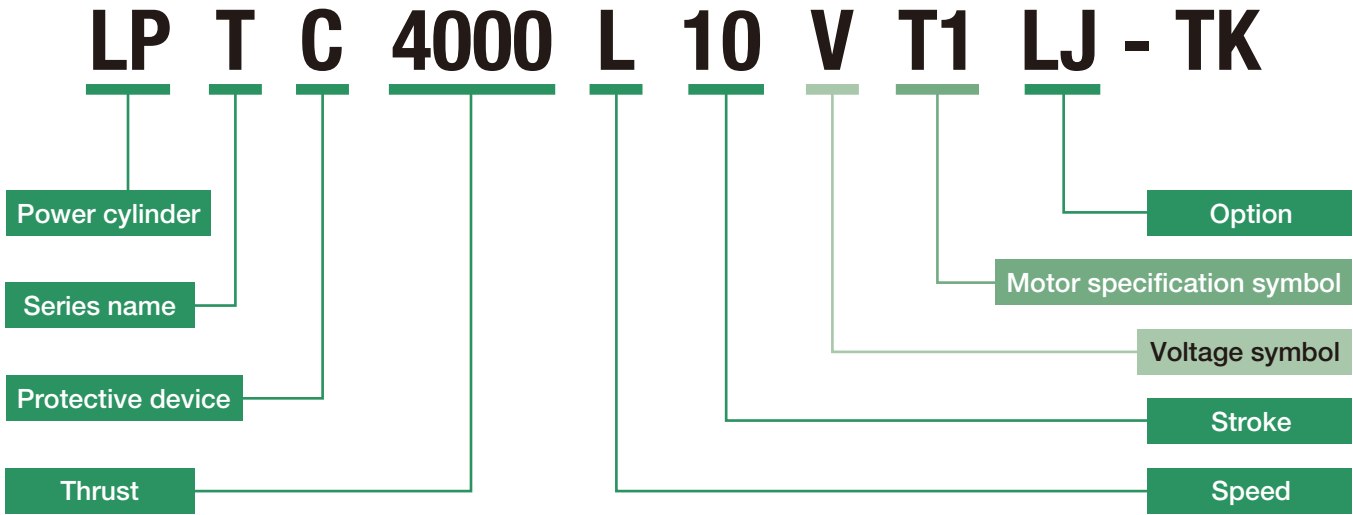

	Voltage symbol	Motor specification symbol	Model No. specification
Standard specification	No symbol		200V class
	V		400V class
Different voltage specification	V1		380V, 50Hz
	V2		380V, 60Hz
	V3		415V, 50Hz
	V4		460V, 60Hz
Heat resistance specification		T1	200V class, heat resistance class F, 40°C
		T2	200V class, heat resistance class F, 60°C
		T3	200V class, heat resistance class F, 80°C
		T4	200V class, heat resistance class H, 80°C
	V	T1	400V class, heat resistance class F, 40°C
		T2	400V class, heat resistance class F, 60°C
		T3	400V class, heat resistance class F, 80°C
		T4	400V class, heat resistance class H, 80°C

	Voltage symbol	Motor specification symbol	Model No. specification
Different voltage specification + heat resistance specification	V1	T1	380V 50Hz, heat resistance class F, 40°C
		T2	380V 50Hz, heat resistance class F, 60°C
		T3	380V 50Hz, heat resistance class F, 80°C
		T4	380V 50Hz, heat resistance class H, 80°C
	V2	T1	380V 60Hz, heat resistance class F, 40°C
		T2	380V 60Hz, heat resistance class F, 60°C
		T3	380V 60Hz, heat resistance class F, 80°C
		T4	380V 60Hz, heat resistance class H, 80°C
	V3	T1	415V 50Hz, heat resistance class F, 40°C
		T2	415V 50Hz, heat resistance class F, 60°C
		T3	415V 50Hz, heat resistance class F, 80°C
		T4	415V 50Hz, heat resistance class H, 80°C
	V4	T1	460V 60Hz, heat resistance class F, 40°C
		T2	460V 60Hz, heat resistance class F, 60°C
		T3	460V 60Hz, heat resistance class F, 80°C
		T4	460V 60Hz, heat resistance class H, 80°C

	Voltage symbol	Motor specification symbol	Model No. specification
Inverter specification		Z	200V class inverter drive supported
		ZV	400V class inverter drive supported <sup>Note 1</sup>
Global specification		N	200V class CE-compliant
		N2	200V class UL-compliant
		N3	200V class CCC-compliant
	V	N	400V class CE-compliant
		N2	400V class UL-compliant
		N3	400V class CCC-compliant
Explosion-proof specification		D	200V class d2G4-compliant
	V	D	400V class d2G4-compliant
Adapter specification		A	Adapter supported

Note 1) ZV only for double voltage with inverter drive supported.

\* All special specifications of brake motors other than the above shall be expressed as "X."

Contact us for reference delivery time of a lot of 5 units or more (3 units or more in the case of explosion-proof specification).

## Power Cylinder

# Multi series

### Thrust : 4.94kN to 314kN {500kgf to 32000kgf}

This is a power cylinder that allows multiple use of cylinders to completely synchronize by one motor. Compact economy type (LPTB) and thrust detecting type with a safety device (LPTC) are available. Select a type according to the application.

- **Tough configuration**

Operating part to carry a load is separated from the reduce part. There is no change in gear tooth contact due to fluctuation load.

- **multiple use of some units is allowed**

multiple use of some units is allowed by use of an input shaft with sufficient strength.

- **Long life**

Long life is realized by adopting a ball screw with a large load capacity.

- **Swinging operation is allowed**

Since the input shaft and trunnion part have the same shaft center, swing is allowed while linkage operation is performed.

- **Safety**

Thrust detecting mechanism to detect overload and protect can be built in. (LPTC)





## Model No. designation

# LP TB 1000 BR6LIJ

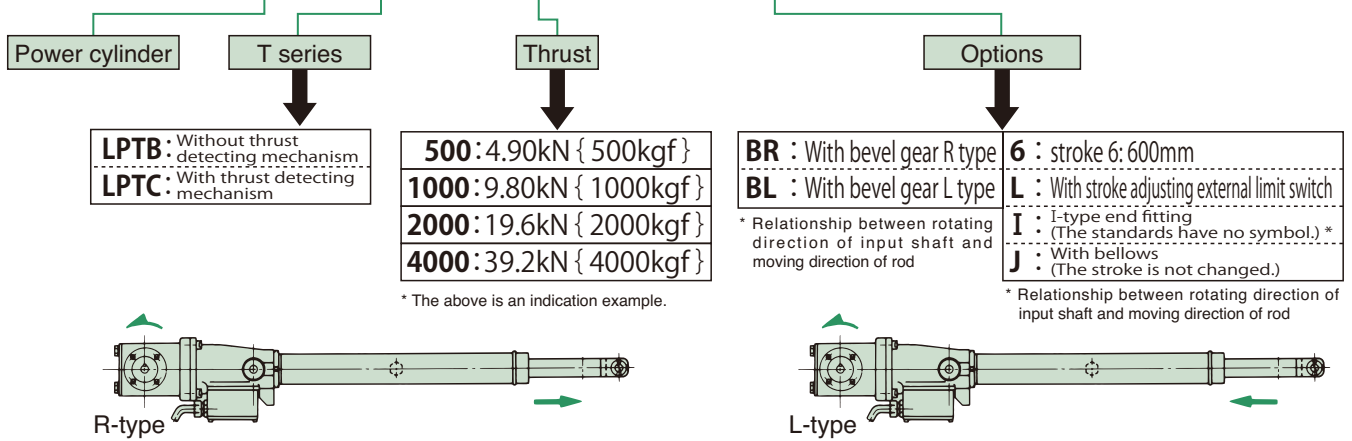

## Standard model list

Power cylinder model	LPT500B	LPT1000B	LPT2000B	LPT4000B	LPT6000B	LPT8000B	LPT12000B	LPT16000B	LPT32000B	
Rated thrust	kN	4.90	9.80	19.6	39.2	58.8	78.4	117	156	313
	{ kgf }	500	1000	2000	4000	6000	8000	12000	16000	32000
Screw lead	mm	6	8	10	12	12	16	16	24	24
Gear ratio		2	2	2	2	2	2	2	2	2
Total efficiency	%	85.5	85.5	85.5	85.5	85.5	85.5	85.5	85.5	85.5
No-load idling torque	N·cm	0.74	2.06	5.19	14.7	23.5	108	160	331	624
	{ kgf·cm }	0.075	0.21	0.53	1.5	2.4	11	16.3	33.8	63.7
Holding torque	N·m	1.78	4.74	11.9	28.4	42.7	75.9	114	228	455
	{ kgf·m }	0.18	0.48	1.21	2.90	4.35	7.74	11.6	23.2	46.4
Allowable input torque Note 1)	N·m	11.0	29.3	73.2	176	264	471	353	707	1413
	{ kgf·m }	1.12	2.99	7.47	17.9	26.9	48.1	36.1	72.2	144.2
Required input torque to rated thrust Note 2)	N·m	2.74	7.32	18.3	43.9	65.9	118	177	354	707
	{ kgf·m }	0.28	0.75	1.87	4.48	6.73	12.0	18.0	36.1	72.1
Rod movement in one turn of input shaft	mm	3	4	5	6	6	8	8	12	12
Maximum input rotation speed Note 3) r/min	L P T B	2400	1800	1080	720	500	382.5	255	180	120
	L P T C	1200	900	720	420	300	270	165	120	90
Rod rotation force at rated thrust	N·m	5.20	13.8	34.7	83.2	124	222	333	666	1330
	{ kgf·m }	0.53	1.41	3.54	8.49	12.7	22.6	34.0	67.9	136
Stroke	mm	200, 300	200, 300	200, 300	200, 300	500	500	500	500	500
		400, 500	400, 500	400, 500	400, 500	1000	1000	1000	1000	1000
		600, 800	600, 800	600, 800	600, 800	1500	1500	1500	1500	1500
					1000, 1200			2000	2000	2000
Approximate weight	kg	21~25	25~35	39~51	102~137	122~174	187~256	206~318	337~502	1130~1490

Note 1) Allowable torque for only input shaft. (Check this torque before multiple operation.)

Note 2) Values including no-load idling torque.

Note 3) When intending to use exceeding the maximum input rotation speed, consult us beforehand.

Note 4) When using at half of the rated thrust or lower, consult TEM because of different idle torque at no load.

## Standard use environment

Environment	Ambient temperature	Impact resistance value
Outdoor type	-20°C to 80°C	3 G or less

1) This use environment shows values for the power cylinder body only. For a driving part other than this standard, consider separately.

2) Power cylinders with bellows are recommended in an excessively dusty location.

3) For locations exposed to sea breezes and salt, it is possible for some specifications such as painting specifications, structure of adjusting limit switch to be changed.

## Painting color

TSUBAKI olive gray (Munsell 5GY6/0.5 Approximate color)

## Structure

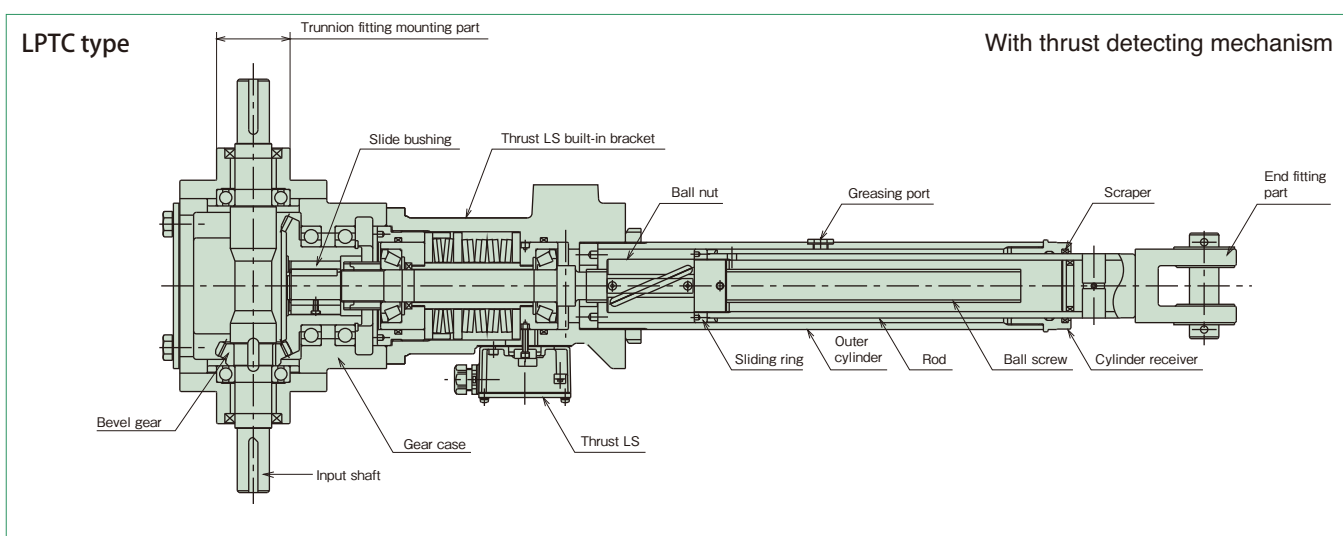
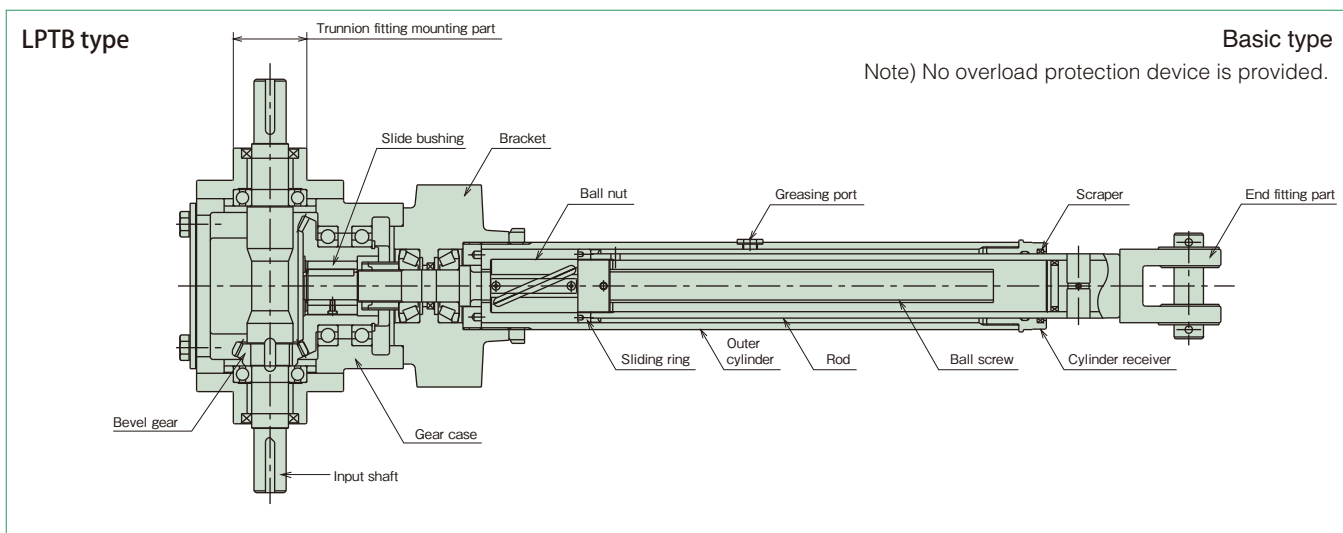

\* Structure slightly varies depending on model.

**Operating part** — The operating part uses a ball screw to convert rotating force into linear motion. And this part is equipped with an external limit switch for stroke adjustment. Adopts a ball screw of high transmission efficiency and high load capacity, and has features of long life and easy maintenance. The stroke can be freely adjusted by the external limit switch. Additionally, the bellows are extremely weather resistant and the stroke does not change, even when fitted.

**Reducer part** — The reducer part adopts a spiral bevel gear, and has high transmission capacity due to special heat treatment. The spiral gear is supported by a dedicated bearing so there is no thrust force effect. Therefore the tooth contact does not change even with load variation. Transmission capacity is also ensured. Since the input shaft and trunnion fitting have the same shaft center, swing motion is allowed. Lubrication for the reducer part is a grease bath type.

## Classification of usage for LPTB and LPTC types

Both types of the power cylinders have the same basic functions (thrust, speed, stroke), however, the features of each mechanism will differ. Read the following to select the optimum type.

### TB type

#### ● Basic type (without overload protection device)

\* For mechanical protection and for electric overload detection on the input side, combination with our shock relay is recommended.

### TC type

#### ● Thrust detecting mechanism type

This type exerts its effect in the following cases.

- ① When performing press (pull) stop
- ② When requiring electric signal at overload
- ③ When overload is possibly applied from load side during stoppage  
When overload is impulsively applied, the incorporated spring deflects to absorb an impact load.

#### [Thrust detecting mechanism]

This is a thrust detecting mechanism which combines two types of pre-loaded disc springs whose spring constants are different from each other and limit switches. The combination effect of these disc springs also allows for press and stop of high speed type. (There is only one type for the 6000 type or larger.)

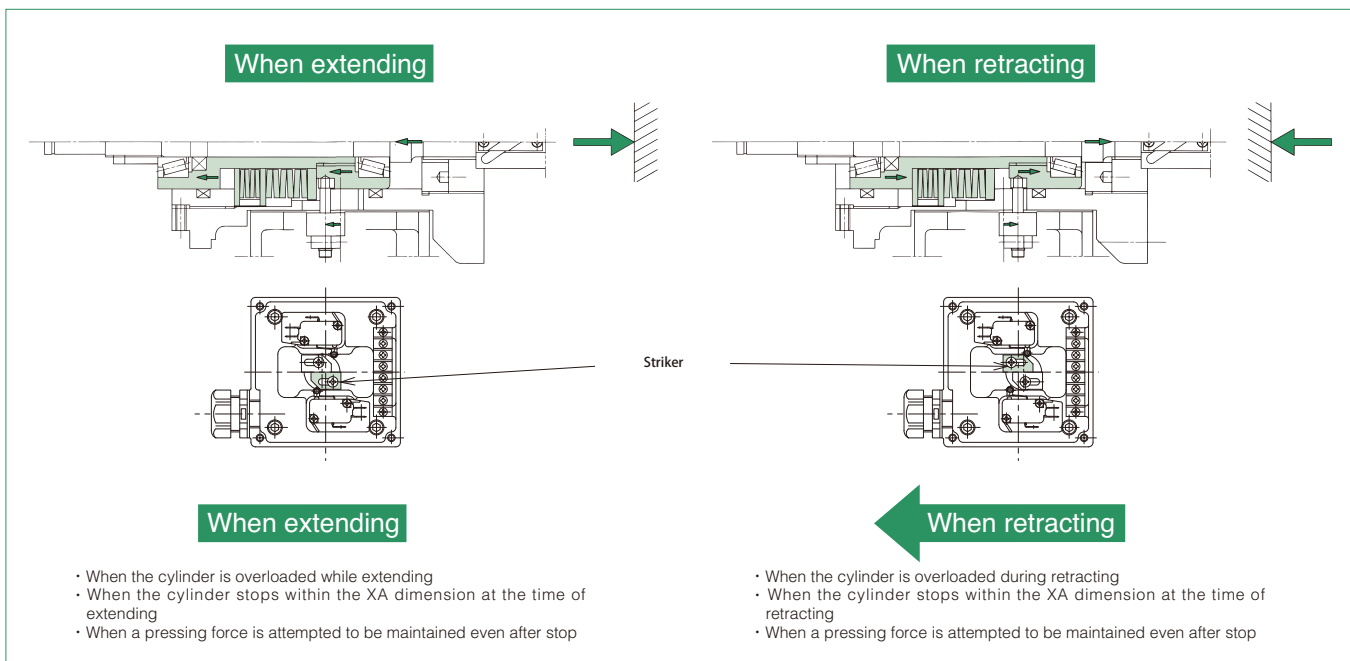

## Cautions for use

#### ● When pressing (pulling) and stopping at high frequency

When using the power cylinder at a frequency of ten or more times a day, refer to the reference total stop times for each model in the table below.

Type	LPTC250~LPTC4000			LPTC6000~LPTC32000		
	S,L	M	H	S,L	M	H
Reference total stop times (x 10 <sup>4</sup> times)	30	10	5	10	3	1

Note) When the power cylinder is used with press (pull) stop and with internal stop, the wire connection for the brake is recommended to be external wiring.

Note) When the power cylinder is used exceeding the value in the above table, it is recommended to stop with the stroke adjusting LS, however, when press (pull) stop, or internal stop is required due to circumstances of the equipment, consult us.

Note) When the power cylinder is used with press (pull) stop, strength of the mating equipment shall be 250% or more of the rated thrust.

#### ● When multiple operation run or stroke position control is performed

**When there is a problem with movement of the rod even if overload is applied from load side during stop**

For the TC type, a spring mechanism is built in the operating part, therefore, when a large load is applied from the load side, the spring deflects and the rod moves by the degree of deflection.

When the load is eliminated, the rod returns to the original position.

## Selection of cylinder

### Conditions of use required for selection

1. Machine to be used and application
2. Thrust or load N { kgf }
3. Stroke mm
4. Speed mm/s
5. Frequency of operation, number of cycles/min.
6. Hours of operation and annual number of operating days
7. Type of load of machine used
8. Environment of use

### Selection procedures

1. Select either one of LPTB or LPTC according to the application.
2. Determine an operation factor from characteristics of load, and machine to be used.
3. Determine annual traveling distance from the stroke, frequency of operation and hours of operation.

$$\text{Annual traveling distance (km)} = \text{Actual stroke (m)} \times \text{Frequency of use/day} \times \text{number of operating days} \times 10^{-3}$$

4. If load greatly varies in the middle of the stroke, calculate the equivalent load by the following equation.

$$P_M = \frac{P_{MIN} + 2 \times P_{MAX}}{3}$$

$P_M$  : Equivalent load N { kgf }  
 $P_{MIN}$  : Minimum load N { kgf }  
 $P_{MAX}$  : Maximum load N { kgf }

5. Multiply equipment maximum load by operation factor, and for multiple operation, divide by multiple factor and number of multiple units to obtain corrected thrust.

$$\text{Corrected thrust} = \frac{\text{Equipment maximum load} \times \text{operation factor}}{\text{number of multiple units} \times \text{multiple factor}}$$

● Operation factor

Characteristics of load	Example of machine used	Operation factor
Smooth operation without impact Small inertia	Damper, opening/closing of valve, conveyor switching device	1.0~1.3
Operation with light impact Intermediate inertia	Opening/closing of hopper gate, various transfer equipment, various lifter elevation	1.3~1.5
Operation with large impact and vibration Large inertia	Heavy object conveyance by carriage, buffer for belt conveyor, inversion opening/closing equipment for large lid	1.5~3.0

Note) The above operation factor table shows general guidelines. As such, determine in consideration of operating conditions.

● Multiple factor

Number of multiple (units)	2	3	4	5	6
multiple factor	1.0	1.0	1.0	0.8	0.67

Note ) Number of multiple units is up to six units.

6. Select model No. to be used from the standard models based on the corrected thrust and stroke.
7. Calculate life from the load – life chart and compare it with the annual traveling distance to check the life.

Load-Life chart

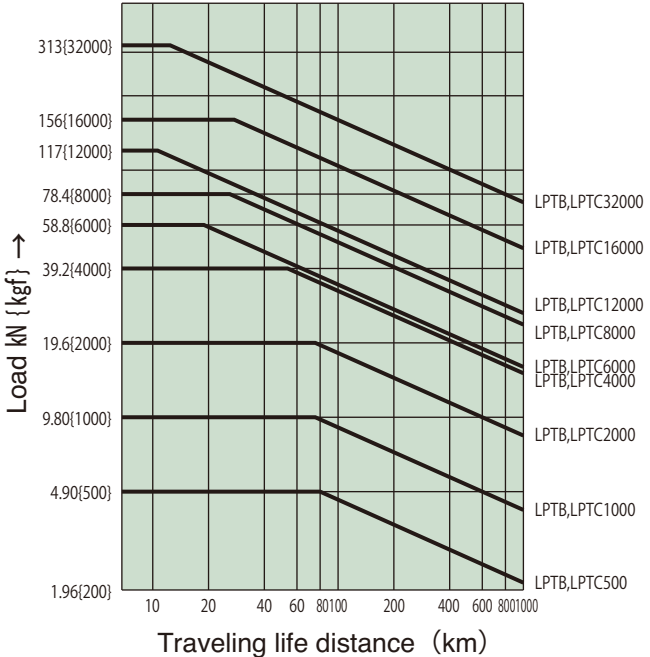

The life distance has been calculated from B<sub>10</sub>\* life.

\* B<sub>10</sub> life is a life which 90% or more of a group of the same ball screws which are operated under the same condition expire without flaking.

## Selection of driving source

As a driving motor, motors with a speed reducer, DC motors, servomotors or ball change motors are available. The motor to be used rotates in reverse by load because the power cylinder is highly efficient. Make sure to use a motor with a brake. Use a brake of a spring close type and with brake torque 150% or more.

- Select a driving motor according to the following equation.

Calculate necessary input torque and use a motor which satisfies the calculated torque value.

For specifications of the power cylinder, refer to page 125.

$$T = \frac{W \times \ell}{2 \times \pi \times R \times \eta \times 1000} + \frac{T_0}{100}$$

- T : Necessary input torque N · m { kgf · cm }
- W : Load N { kgf }
- ℓ : Screw lead mm
- R : Gear speed ratio=2
- η : Total efficiency=0.855
- T<sub>0</sub> : No-load idling torque N · cm { kgf · cm }

Note) Note that, if any motor of a larger capacity than necessary is used, when it is locked in the course of the stroke, impact load acts on the power cylinder due to rotation energy of the motor, resulting in breakage.

Wire connection should be carried out according to brake individual turnoff.

# Dimensions Table

## LPTB basic type

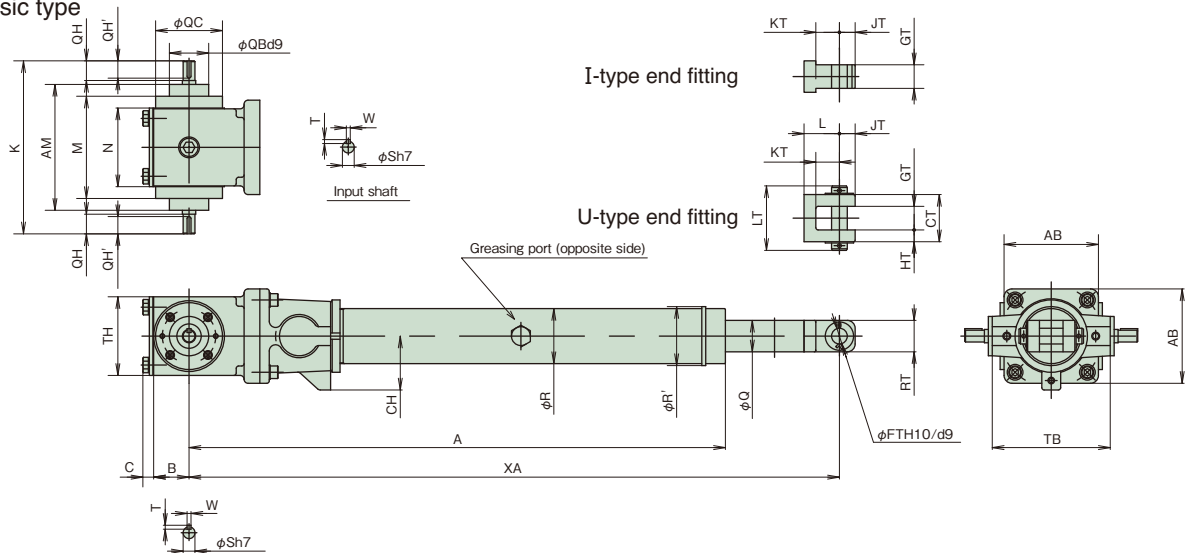

Unit: mm

Model	Stroke	Length		Input shaft					Input shaft bracket				Gear case				Bracket inner/outer cylinder					End fitting																	
		A	X <sub>MIN</sub>	S	W	T	QH	QH'	K	QB	QC	AM	M	AB	TH	B	C	N	CH	TB	Q	R	R'	RT	CT	GT	HT	LT	KT	L	JT	FT							
LPTB 500	200	470	565																																				
	300	570	675																																				
	400	670	785																																				
	500	770	895	15	5	5	25	22	220	50	85	160	130	120	100	45	14	100	68.5	130	35	58	63	36	50	25	12.5	69	25	35	18	16							
	600	870	1000																																				
	800	1070	1220																																				
1000	200	500	605																																				
	300	600	715																																				
	400	700	825																																				
	500	800	935	15	5	5	25	22	220	50	85	160	130	120	100	45	14	100	48	150	40	70	75	40	60	30	15	82	30	45	20	20							
	600	900	1040																																				
	800	1100	1260																																				
2000	200	560	680																																				
	300	660	790																																				
	400	760	900																																				
	500	860	1010	20	6	6	30	25	270	60	110	200	160	130	130	55	17	130	71	180	50	76	81	50	70	35	17.5	99	40	60	25	25							
	600	960	1115																																				
	800	1160	1335																																				
4000	200	645	780																																				
	300	745	890																																				
	400	845	1000																																				
	500	945	1105	35	10	8	70	60	450	80	160	300	230	190	190	80	19	190	90	220	70	95	100	70	80	40	20	115	50	75	35	32							
	600	1045	1215																																				
	800	1245	1430																																				
1000	1445	1645																																					
1200	1645	1865																																					
6000	500	1075	1230																																				
	1000	1575	1780	35	10	8	70	60	480	80	160	330	260	220	220	80	26	220	-	260	80	115	-	80	-	45	-	-	65	-	40	40							
	1500	2175	2430																																				
8000	500	1145	1310																																				
	1000	1645	1860	40	12	8	80	70	550	90	180	380	300	260	240	90	29	240	-	310	95	130	-	95	-	50	-	-	70	-	45	45							
	1500	2145	2410																																				
12000	500	1205	1390																																				
	1000	1705	1940																																				
	1500	2205	2490	40	12	8	80	70	550	90	180	380	300	260	240	90	29	240	-	350	110	160	-	110	-	65	-	-	90	-	55	50							
	2000	2705	3040																																				
16000	500	1370	1570																																				
	1000	1870	2120																																				
	1500	2370	2670	50	14	9	85	75	630	120	220	440	340	320	280	110	33	280	-	400	130	180	-	130	-	80	-	-	100	-	65	63							
	2000	2870	3220																																				
32000	500	1795	2055																																				
	1000	2295	2605																																				
	1500	2795	3155	60	18	11	120	100	940	200	320	680	520	500	450	175	36	450	-	540	180	240	-	180	-	125	-	-	140	-	90	90							
	2000	3295	3705																																				

**Dimensions Table**

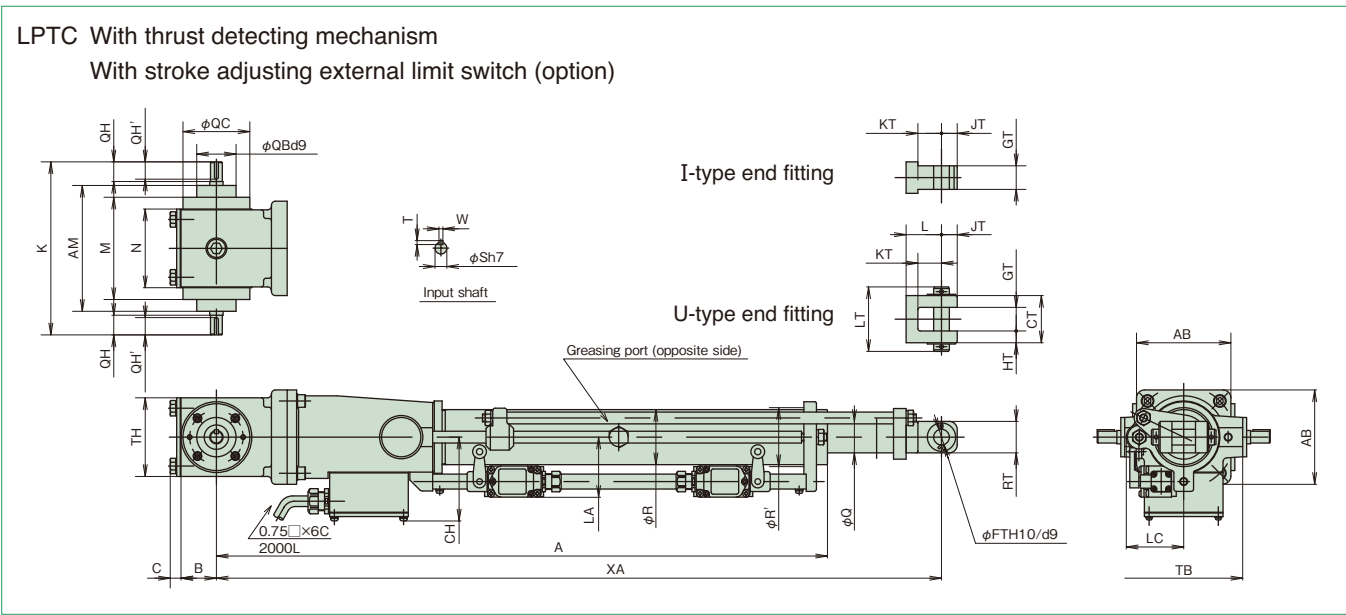

Unit: mm

Model	Stroke	Length		Input shaft							Input shaft bracket				Gear case			Bracket inner/outer cylinder						End fitting										limit switch	
		A	XA MIN	S	W	T	QH	QH'	K	QB	QC	AM	M	AB	TH	B	C	N	CH	TB	Q	R	FT	RT	CT	GT	HT	LT	KT	L	JT	LA	LC		
LPTC 500	200	555	650	15	5	5	25	22	220	50	85	160	130	120	100	45	14	100	101	130	35	58	16	36	50	25	12.5	69	25	35	18	161	73		
	300	655	760																																
	400	755	870																																
	500	855	980																																
	600	955	1085																																
	800	1155	1305																																
1000	200	595	700	15	5	5	25	22	220	50	85	160	130	120	100	45	14	100	107	150	40	70	20	40	60	30	15	82	30	45	20	161	73		
	300	695	810																																
	400	795	920																																
	500	895	1030																																
	600	995	1135																																
	800	1195	1355																																
2000	200	675	795	20	6	6	30	25	270	60	110	200	160	130	130	55	17	130	110	180	50	76	25	50	70	35	17.5	99	40	60	25	164	76		
	300	775	905																																
	400	875	1015																																
	500	975	1125																																
	600	1075	1230																																
	800	1275	1450																																
4000	200	790	925	35	10	8	70	60	450	80	160	300	230	190	190	80	19	190	127	220	70	95	32	70	80	40	20	115	50	75	35	182	85		
	300	890	1035																																
	400	990	1145																																
	500	1090	1250																																
	600	1190	1360																																
	800	1390	1575																																
6000	500	1170	1325	35	10	8	70	60	480	80	160	330	260	220	220	80	26	220	139	260	80	115	40	80	—	45	—	—	65	—	40	—	—		
	1000	1670	1875																																
	1500	2270	2525																																
8000	500	1245	1410	40	12	8	80	70	550	90	180	380	300	260	240	90	29	240	145	310	95	130	45	95	—	50	—	—	70	—	45	—	—		
	1000	1745	1960																																
	1500	2245	2510																																
12000	500	1305	1490	40	12	8	80	70	550	90	180	380	300	260	240	90	29	240	160	350	110	160	50	110	—	65	—	—	90	—	55	—	—		
	1000	1805	2040																																
	1500	2305	2590																																
	2000	2805	3140																																
16000	500	1460	1660	50	14	9	85	75	630	120	220	440	340	320	280	110	33	280	170	400	130	180	63	130	—	80	—	—	100	—	65	—	—		
	1000	1960	2210																																
	1500	2460	2760																																
	2000	2960	3310																																
32000	500	1950	2210	60	18	11	120	100	940	200	320	680	520	500	450	175	36	450	238	540	180	240	90	180	—	125	—	—	140	—	90	—	—		
	1000	2450	2760																																
	1500	2950	3310																																
	2000	3450	3860																																



# Options

## Bellows

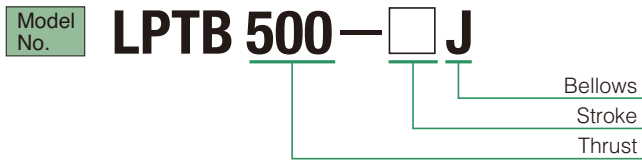

## Trunnion

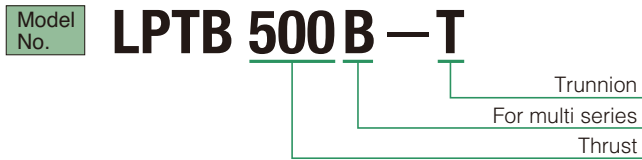

## ● Dimensions of bellows

Unit: mm

LPTB LPTC	500	1000	2000	4000	6000	8000	12000	16000	32000
D	90	90	90	120	135	150	180	210	250

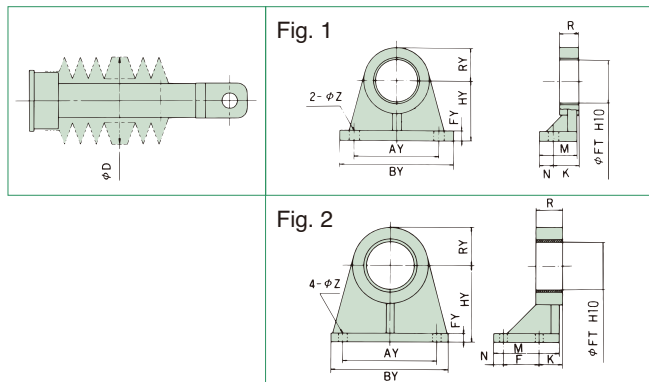

## ● Multi series trunnion fitting

Unit: mm

Model	Applicable body model No.	AY	BY	FY	HY	RY	FT	F	K	M	N	R	Z	Form	Mass (kg)
LPTB500B-T	LPTB LPTC 500B	130	180	15	150	40	50	—	45	65	25	15	18	Fig. 1	5.7
	LPTB LPTC 1000B														
LPTB2000B-T	LPTB LPTC 2000B	150	200	15	170	50	60	—	45	65	25	20	18	Fig. 1	9.4
	LPTB LPTC 4000B														
LPTB4000B-T	LPTB LPTC 4000B	180	240	20	170	70	80	—	55	80	30	35	22	Fig. 1	22.8
	LPTB LPTC 6000B														
LPTB8000B-T	LPTB LPTC 8000B	250	320	25	280	80	90	80	80	185	35	40	27	Fig. 2	60.5
	LPTB LPTC 12000B														
LPTB16000B-T	LPTB LPTC 16000B	320	400	30	320	100	120	90	90	210	40	50	33	Fig. 2	95.7
LPTB32000B-T	LPTB LPTC 32000B	400	500	35	380	160	200	120	120	275	50	80	45	Fig. 2	220.0

\* Note that there are some models which may interfere with the bracket in an installation method in which the trunnion fitting installation face is on the cylinder end.

# Limit switch specifications

	Stroke adjusting external LS	Thrust detecting LS (LPT16000 or less)	Thrust detecting LS (LPT32000)
Limit switch type	WLCA2(OMRON) or equivalent	V-165-1AR5(OMRON) or equivalent	Z-15GW22-B(OMRON) or equivalent
Electric capacity	250V AC 10A (cosφ=0.4)	250V AC 10A (cosφ=0.4)	250V AC 10A (cosφ=0.4)
Contact configuration	NC 1 — ● — 4 NO NC 2 — ● — 3 NO	Retracting side	Extending side
(Applicable cable outer diameter)	SCS-10B (φ8.5~φ10.5) PF1/2	SCL-14A (φ10.5~φ12.5) PF1/2	SCS-14A (φ10.5~φ12.5) PF1/2

# Electric wiring

An electric wiring diagram is shown on the right.

Carry out sequence as a guide.

LS01, LS03, LS05 Extending side thrust detecting limit switch  
 LS02, LS04, LS06 Retracting side thrust detecting limit switch } Linkage of three units  
 LS11, LS12 Stroke adjusting limit switch

## ● Power cylinder reference circuit

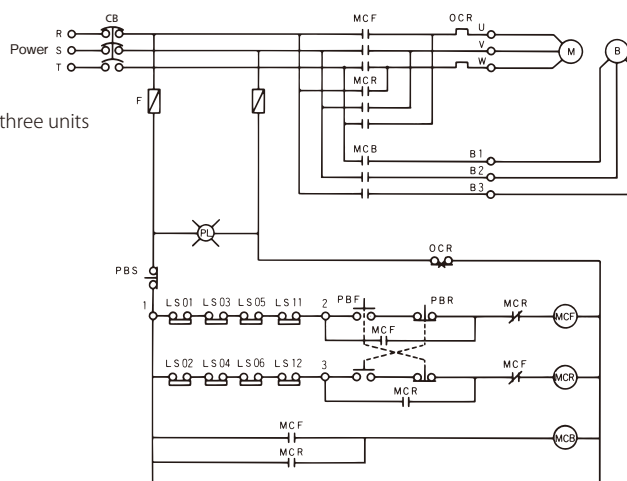

## Maintenance and inspection

### Greasing on ball screw

Use the ball screw as it is because it has been lubricated with grease in advance. Refill grease with reference to the Table below as a guide. To apply grease to the ball screw, remove the greasing port bolt on the outer cylinder and advance the rod in the full stroke and apply grease to the outer circumference of the screw with a grease gun.

#### ● Lubrication cycle

Operating frequency	Lubrication cycle
500 to 1000 times/day	Three to six months
100 to 500 times/day	Six months to one year
10 to 100 times/day	One to one and half year

Note) The above values are for longer use, and do not indicate the life.

#### ● Recommended grease

Use classification	Company name	Grease name
Ball screw	TSUBAKI E&M	JWGS100G
	IDEMITSU KOSAN	*DAPHNE EPONEX SRNo.2
	NIPPON GREASE	NIGULUBE EP-2K
	EXXON MOBILE	MOBILUX EPNo.2
	COSMO OIL LUBRICANTS	COSMO GREASE DINAMAX EPNo.2
	SHOWA SHELL	SHELL ALBANIA EP grease 2

\* The above greases are filled before shipment.  
Note) JWGS100G is separately sold in a container of 100g.

### Greasing on Reduction part

For the gear and the bearing in the reducer part, the gear case is filled with grease. Accordingly, it is not necessary to grease because they normally endure use for one year or longer. However, operation for a long time or use after long storage impairs lubrication effect due to deterioration of grease. As such, inspect and fill the grease.

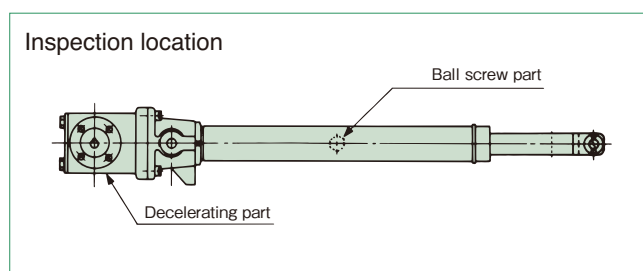

**WARNING**

Never insert your finger into the greasing port.  
If the cylinder operates with your finger inserted, your finger may be injured.

### Synchronizing operation

Multi series has a feature to ensure synchronization of multiple power cylinders. Refer to the layout shown below to plan synchronizing operation.

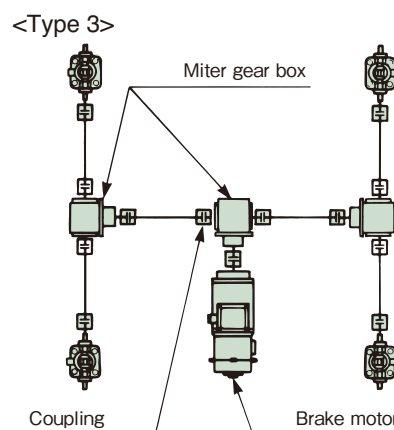
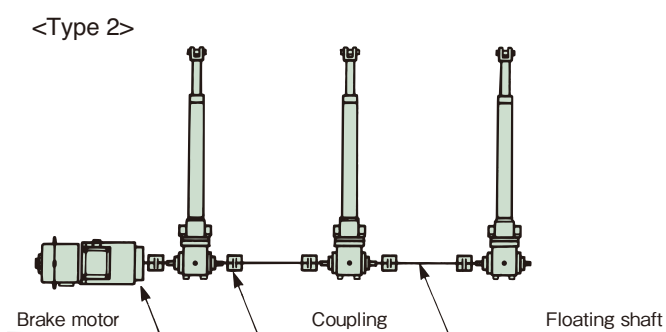
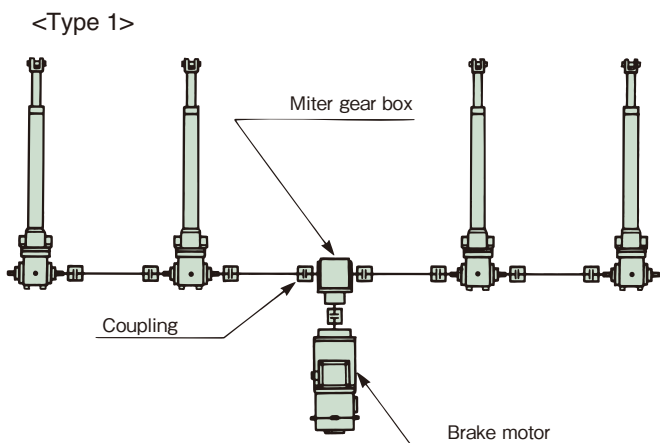

# ! WARNING

## ■ Cautions for selecting

- The LPTB type of the multi series is not equipped with an overload protecting function. If an overload protecting function is required on the cylinder main body, select the LTPC type.
- If this cylinder is used for press contact or pull contact stopping, the strength of the mating equipment side must be 300% or more of the rated thrust.
- When installing a sprocket, a gear or a pulley on the input or output shaft, check that an overhang load acting on the shaft is less than the allowable overhang load.

$$\text{Allowable O. H. L.} \geq \frac{T \cdot f \cdot Lf}{R}$$

O.H.L. : O. H. L: Overhang load (N { kgf })  
 T : Load torque (N·m { kgf·m })  
 f : Transmission element factor  
 Lf : Factor by load acting position  
 R : Pitch circle radius of sprocket, gear, V pulley (m)

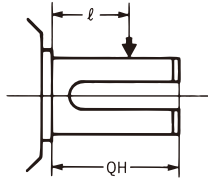

QH : Length of shaft  
 l : Load acting position

### ● Transmission element factor (f)

Sprocket	1.00
Gear	1.25
V belt	1.50
Flat belt	2.50

### ● Factor by load acting position (Lf)

l/QH	0.25	0.38	0.5	0.75	1
Lf	0.8	0.9	1	1.5	2

● Table 1

Power cylinder model	LPTB,TC 500	LPTB,TC 1000	LPTB,TC 2000	LPTB,TC 4000	LPTB,TC 6000	LPTB,TC 8000	LPTB,TC 12000	LPTB,TC 16000	LPTB,TC 32000	
Allowable overhang load	N { kgf }	549 {56}	1.06k {108}	1.95k {199}	3.49k {356}	4.60k {469}	6.75k {689}	8.85k {903}	14.0k {1430}	22.3k {2280}

## ■ Cautions for installation

- Securely carry out centering between the center of the trunnion fitting and the center of the end fitting mount part. Prevent lateral load from acting on the cylinder due to swing particularly when the cylinder operates.
- Coupling is recommended to couple the input shaft and the driving shaft. Use a type of coupling including chain coupling, gear coupling and disk coupling which can absorb misalignment.
- Note that, if the floating shaft of the coupling to couple the driving part and cylinders is long, vibration may be generated by its rotation. Consider together with rigidity of the floating shaft and backlash of the coupling.
- Apply grease to the connecting pin on the end fitting.
- All models are totally enclosed structures so that they can be used normally outdoors, however, under adverse conditions exposed to constant water and steam etc., and snow accumulation, although they are an outdoors type, an appropriate cover is required. The power cylinder can generally be used in a range of -20°C to 40°C, although it varies depending on the conditions of use. When using at 40°C or higher, always protect with a heat insulating cover, etc. Never use in a flammable atmosphere, otherwise it may cause an explosion and fire. In addition, avoid using it in a location where vibration or shock exceeding 1G is applied.
- For use in a misty atmosphere, contact us.

## ■ Cautions for use

- Regulate both ends of the stroke by the limit switch. Select a type of option which allows the limit switch to be mounted on the power cylinder body.
- Use within the stroke range. If the stroke is exceeded, breakage may occur.
- If the power cylinder multi series is used at high speed, since the coasting distance is long, the striker may override the limit switch. For this reason, make sure to allow the limit signal to be self-held on the control circuit.
- Anti-rod rotation is required because a rotating force is generated on the rod with thrust. The rod rotating force at the rated thrust is described in the model list. When operating with the end unconnected or when installing pulleys to pull a rope, contact us since a rod anti-rotation specification is also available.
- Adjustment of the limit switch for thrust detection of TC type must not be carried out by the customer. The preset value for thrust detection may greatly change.

## Power Cylinder

# Mini series

### Thrust : 98.0N to 392N {10kgf to 40kgf}

This series is suitable for automation with small force near by for the packaging machine and transfer machine, etc.

- **With single-phase power source is available**  
This can be readily used only with a single-phase power source and ancillary equipment is also unnecessary.  
(Power cylinder with three-phase motor or brake motor is also available.)  
Power cylinders with a potentiometer are optimum for remote operation.
- **Long life design**  
Long life design with a die cast structure, grease hermetically sealed type and large screw diameter.
- **Wide variety of options**  
Wide variety of options such as adjusting limit switches, potentiometers, bellows and trunnion fitting are also available.



## Model No. designation

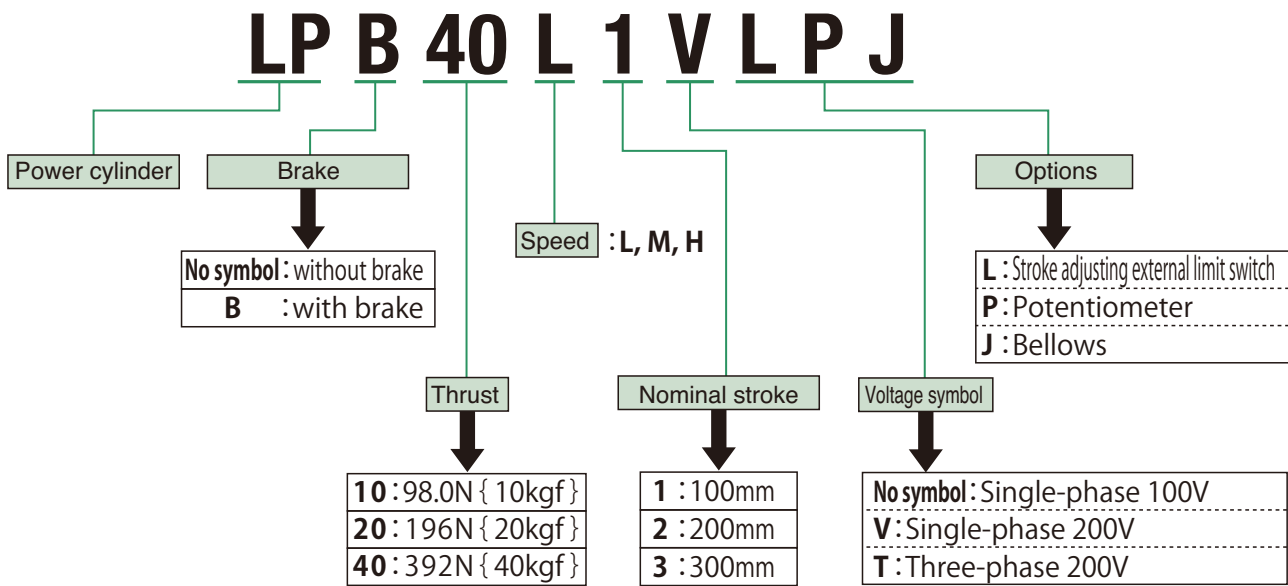

\* Specify LP040-T as a trunion fitting.

\* Power cylinders with a three-phase motor and with a brake motor are also available. (Refer to page 139 through 140.)

\* Be careful not to make mistakes in motor specifications (power supply, voltage and presence or absence of brake).

## Standard model list

Basic type	Model No.			Rated thrust		Rated speed mm/s 50/60Hz	Stroke mm*
	With stroke adjusting external limit switch	With potentiometer	With stroke adjusting external limit switch With potentiometer	N	{ kgf }		
LP 10H1	LP 10H1L	LP 10H1P	LP 10H1LP	98.0	10	34/42	100
LP 10H2	LP 10H2L	LP 10H2P	LP 10H2LP				200
LP 10H3	LP 10H3L	LP 10H3P	LP 10H3LP				300
LP 20M1	LP 20M1L	LP 20M1P	LP 20M1LP	196	20	17/21	100
LP 20M2	LP 20M2L	LP 20M2P	LP 20M2LP				200
LP 20M3	LP 20M3L	LP 20M3P	LP 20M3LP				300
LP 40L1	LP 40L1L	LP 40L1P	LP 40L1LP	392	40	9/11	100
LP 40L2	LP 40L2L	LP 40L2P	LP 40L2LP				200
LP 40L3	LP 40L3L	LP 40L3P	LP 40L3LP				300

\* Mini-series does not take stroke margin into consideration.

## Motor specifications

Model	Condenser run type reversible motor			
Number of poles, output	4P 20W (30 min Heat resistance class E)			
Voltage	single-phase 100V		single-phase 200V	
Frequency	50Hz	60Hz	50Hz	60Hz
Current value	0.64A	0.55A	0.32A	0.28A
Condenser capacity	10 $\mu$ F (Withstand voltage 200V)		2.5 $\mu$ F (Withstand voltage 400V)	
Protecting structure	Totally enclosed type (Indoor type)			

## Standard use environment

Environment	Model	Indoor type
Ambient temperature		-15°C to 40°C
Relative humidity		85% or less (No dew condensation)
Impact resistance value		1G or less
Installation altitude		1000m or lower above sea level
Atmosphere		Indoor location which is not directly exposed to rain, wind, lightning or sunlight. Extent of sand and dust which exist in general factory (5mg/m <sup>3</sup> or less)
Remark		Power cylinders with bellows are recommended in an excessively dusty location.

Note) This cylinder cannot be used outdoors.

## Painting color

TSUBAKI olive gray (Munsell 5GY6/0.5 or approximate color)

Structure

Basic type

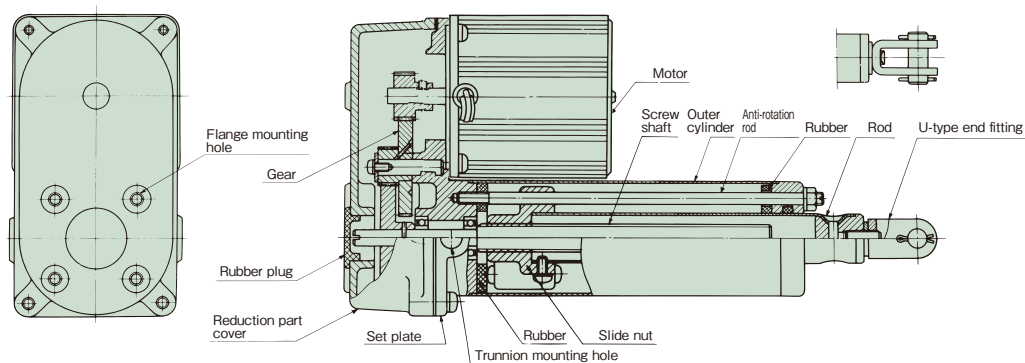

With potentiometer

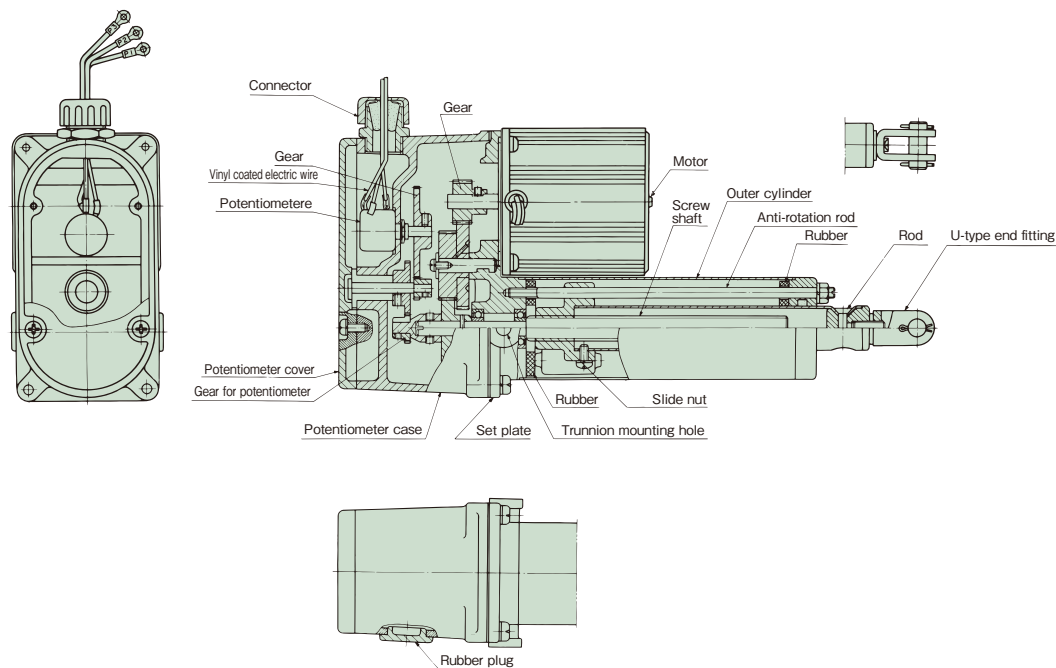

Feature

Power cylinder in a small thrust zone operable with a single-phase power source. Various motors including not only single-phase motors but also three-phase motors or brake motors can be selected.

Since the cylinder body incorporates an anti-rotation function, the cylinder can be used as it is even if used with the end set free.

The model with a potentiometer basically built-in a potentiometer. As the potentiometer is rotated via small gear by rotation of the screw shaft, potentiometer output proportional to the stroke can be obtained.



## Selection

### Conditions of use required for selection

1. Machine to use and application
2. Thrust or load N { kgf }
3. Stroke mm
4. Speed mm/s
5. Frequency of operation, number of cycles/min.
6. Power source voltage, frequency

### Selection procedure

#### Model selection

Determine a model (basic type, with stroke adjusting external limit switch, with potentiometer) according to the application.

#### Selecting model No.

Select an applicable model No. from the standard model list (Page 135) based on the thrust or load (N{kgf}), stroke (mm), and speed (mm/s).

#### Characteristics check

Use the power cylinder at an operating frequency below the allowable operating frequency (Table 1).

Table 1 Allowable operating frequency (Number of cycles/min)

10H1	10H2	10H3	20M1	20M2	20M3	40L1	40L2	40L3
6	3	2	3	1.5	1	1.5	1	0.5

## Installation

### Installation direction

Either horizontal, vertical and inclined direction is allowed.

### Installation method

For installation of the main body, use trunnion fitting (separately sold attachment). (page 139)

Apply grease to the trunnion pin and bracket hole before mounting. Use tap holes (4-M6) on the reducer part cover to install flange, and use U-shape end fitting or tap hole (M8) for installation of the end.

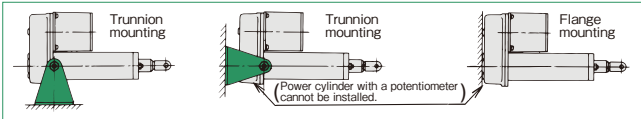

### Installation of external limit switch

1. For power cylinders without a limit switch, separately install a limit switch to regulate the stroke.
2. Check the coasting amount before determination of the mounting position. The coasting amount is approximately 3 to 6mm.
3. Set the limit switch so that the cylinder stops within L dimension in the dimensions table when using in the full nominal stroke.
4. Minimum preset value of the stroke is 60mm.

### Vibration insulation treatment

Load is retained by a self-lock system of the trapezoidal screw. However, since secure retention may be difficult in a vibration conveying location, carry out vibration proofing treatment or select a power cylinder with a brake.

### Manual operation

Remove the rubber plug on the reducer part and turn the shaft with a screwdriver. When it is turned clockwise, the rod retracts to move by 3mm per one turn. The power cylinder with a potentiometer cannot be manually operated.

### Lateral load on rod

Install the power cylinder so as to prevent a bending load (lateral load) from acting on the rod.

## Lubrication

This is of a grease lubrication type. As the power cylinder is applied with grease before shipment, use as it is.

Refill grease with reference to Table 2-3 as a guide when temperature rises or noise increases.

For greasing it is necessary to disassemble the main body since there is no greasing port. For disassembling method, contact us separately.

Table 2 Recommended grease

Company name	Grease name
SUMICO LUBRICANT CO., LTD	Moly gear grease
DOW CORNING	Moly coat EP grease

Note) Use the same grease for the screw and the reducer part.

Table 3 Lubrication cycle

Operating frequency	Lubrication cycle
500 to 1000 times/day	Three to six months
100 to 500 times/day	Six months to one year
10 to 100 times/day	One to one and a half years

Note) The above values are for longer use, and do not indicate the life.

## Wire connection

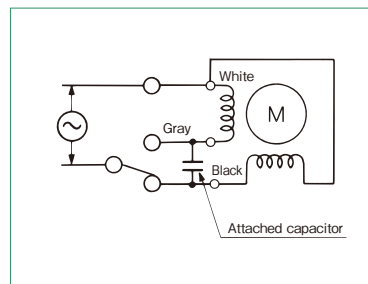

For retracting, turn the switch in reverse.

Attached capacitor 10 μF ----- For single-phase 100V  
(25 μF) --- For single-phase 200V

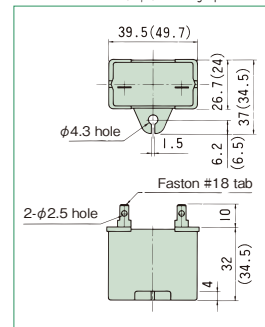

## Limit switch

Model	D2VW-5L2A-1M (OMRON) or equivalent
Electric rating	250V AC 5A (cosφ0.7)
Contact configuration (1C)	(Red) NC (Blue) NO (Black) COM

## Potentiometer

Model	22-HHP-10N (SAKAE TSUSHIN KOGYO CO., LTD.) equivalent
Resistance value	1kΩ
Effective electric angle	360°
Rated power	2W
Withstand voltage	1000V AC (1 minute)

To indicate stroke, use stroke indication meter and print board on page 110.

**Dimensions Table**

Basic type (This diagram shows a power cylinder with stroke adjusting external limit switch.)

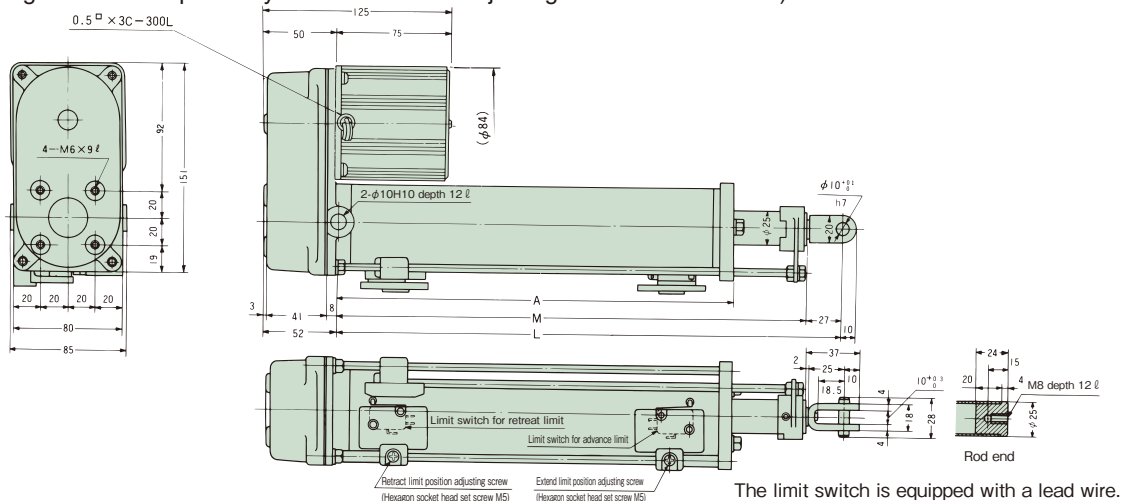

The limit switch is equipped with a lead wire.

Power cylinder with a stroke adjusting external limit switch, with potentiometer

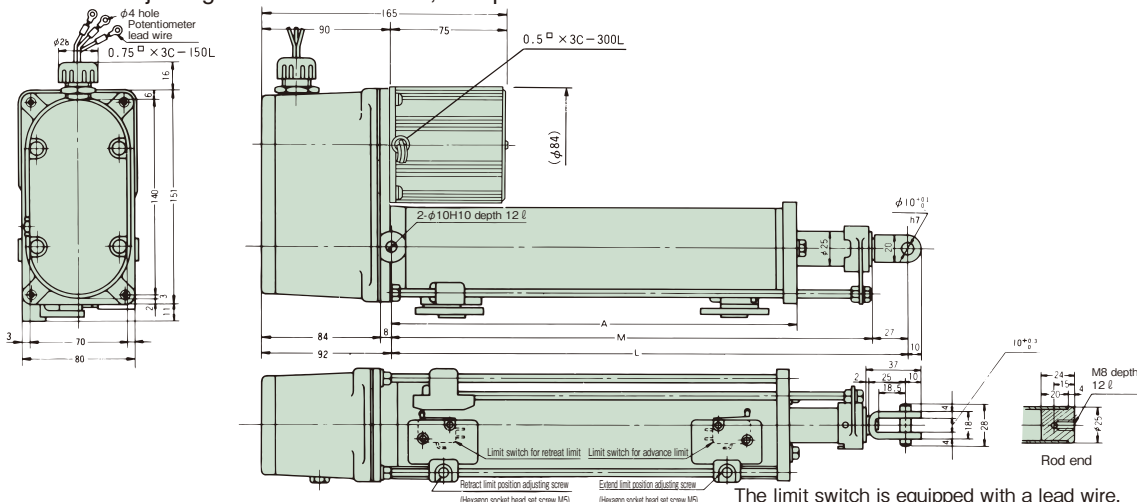

The limit switch is equipped with a lead wire.

Unit: mm

Stroke	A		Minimum	M		L			Approximate mass kg				
	Basic type	With stroke adjusting external limit switch		Minimum	With bellows		Minimum		maximum	Basic type	With LS	With potentiometer	With LS, potentiometer
					Minimum	Stroke	Without bellows	With bellows					
100	176	179	205	205 (230)	100 (75)	232	232 (257)	332	4.0	4.6	5.1	5.6	
200	276	279	305	319 (348)	186 (157)	332	346 (375)	532	4.5	5.1	5.6	6.1	
300	376	379	405	433 (469)	272 (236)	432	460 (496)	732	5.0	5.6	6.1	6.6	

Note) Dimensions in the parentheses indicate a value for power cylinders with a limit switch.

## Options

### ■ Bellows ( -J)

Use bellows when equipment is installed in a location exposed to dust or water.

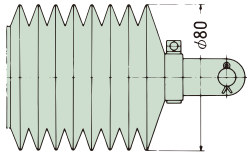

This shows dimension for a cylinder without a limit switch. This dimension is φ65 for the cylinder with a limit switch.

### ■ Trunnion fitting (LP040-T)

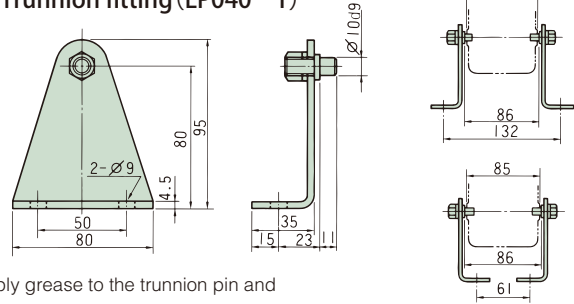

Apply grease to the trunnion pin and trunnion hole before mounting.

## Application

With three-phase motor

### 1. Outline

This is a model which can be used with a three-phase power source.

As this motor is of an induction type, the coasting amount slightly increases. Use this model in an application of relatively low frequency.

### 2. Specifications

Same as those of the standard models except for specifications and dimensions of the motor.

<Outside dimension>

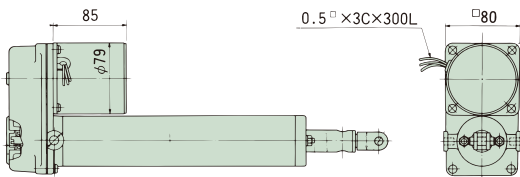

<Specifications of motor>

Power	Three-phase 200V 50/60Hz
Motor model	Induction motor
Time rating	Continuous
Output	25W
Rated current	0.25A
Wire connection	<p>Replace any two wires.</p>

### 3. Model No. designation

**LP40L1T**

Three-phase 200V 50/60Hz

# Application

## With brake motor

### 1. Outline

When you want to increase cylinder stop accuracy or reduce the coasting amount, power cylinders with a brake motor are optimum. Load can be securely retained in a vibration conveying location. All brakes retain a load even at power failure because they are of a deenergization type.

### 2. Specifications

Same as those of the standard models except for specifications and dimensions of the motor.

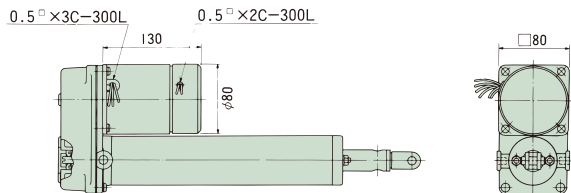

Outside dimensions of capacitors for single-phase 100V and 200V

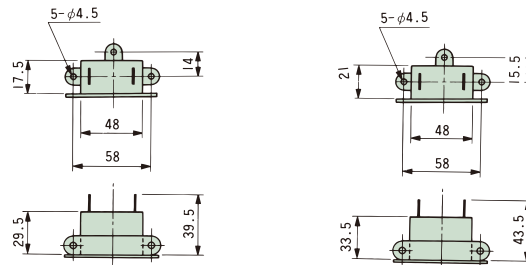

For single-phase 100V (10µF)

For single-phase 200V (2.5µF)

### <Specifications of brake motor>

Power source	Single-phase		Three-phase
	100V 50/60Hz	200V 50/60Hz	200V 50/60Hz
Motor model	Condenser run reversible motor	Condenser run reversible motor	Induction motor
Time rating	30 minutes	30 minutes	Continuous
Output	25W	25W	25W
Rated current	0.8A	0.4A	0.25A
Specifications of brake	Power source	Single-phase 100V	Single-phase 200V
	Input current	12W 0.15A	12W 0.1A
	Static friction torque	1kgf·cm	1kgf·cm

### <Wire connection>

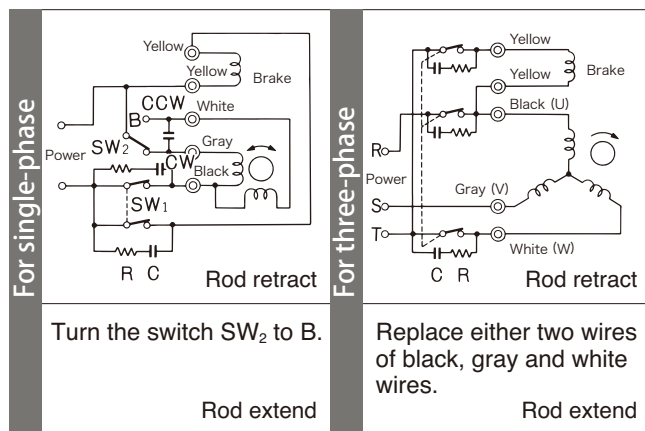

In the connecting diagram, C.R is a contact protecting CR circuit. Make sure to insert a contact protecting CR as shown in the diagram because the contacts to open/close the brake generate spark when the contacts open/close. C=0.1~0.2µF (400V) R=5~200Ω (1/4 W or less) Protecting CR is not attached.

### 3. Model No. designation

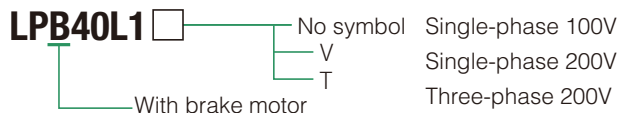

# WARNING

## ■ Cautions for selecting

- Cylinders with bellows are available as an option for dust proofing. Note that the effective stroke is shorter in the case of a cylinder with bellows. For effective strokes, refer to the Dimensions Table.
- This cylinder is not provided with an overload protecting function.
- Even a type without brake calculatory has a self-lock system and retains a load, however, the self-lock system may not work due to vibration or impact. If vibration or impact is given, select a type with a brake.
- For operating frequency, refer to the following table.

### Operating frequency: Number of cycles/min

Model	LP (B) 10H			LP (B) 20M			LP (B) 40L		
Stroke	100	200	300	100	200	300	100	200	300
Number of cycles	6	3	2	3	1.5	1	1.5	1	0.5

## ■ Cautions for installation

- Securely carry out centering between the center of the trunnion fitting and the center of the end fitting mount part. Prevent a lateral load from acting on the cylinder due to swing particularly when the cylinder operates.
- Apply grease to the trunnion pin and the trunnion hole for trunnion mounting.
- Also, apply grease to the connecting pin of the end fitting.
- All models are of ordinary outdoor specification, and it can be used in a location not exposed to water and steam, etc., where dust is in the extent in an ordinary factory. The power cylinder can generally be used in a range of -15°C to 40°C, although it varies depending on the use conditions. When using at 40°C or higher, always protect with a heat insulating cover, etc. Never use in a flammable atmosphere, otherwise it may cause an explosion and fire. In addition, avoid using it in a location where vibration or shock exceeding 1G is applied.

## ■ Cautions for use

- Do not allow a force (traverse load) bending the rod to act.
- For position adjustment by manual operation, remove the rubber plug (opposite side of the cylinder) on the gear case and turn the end of the screw shaft with a screw driver. When it is turned counterclockwise, the cylinder extends. Make sure to turn OFF the power for manual operation. The power cylinder with potentiometer cannot be manually operated.
- When pressing to an external stopper and stopping the cylinder, place a cushion (such as rubber plate) between them. Operate the limit switch so as not to restrain the motor before pressing against the stopper.

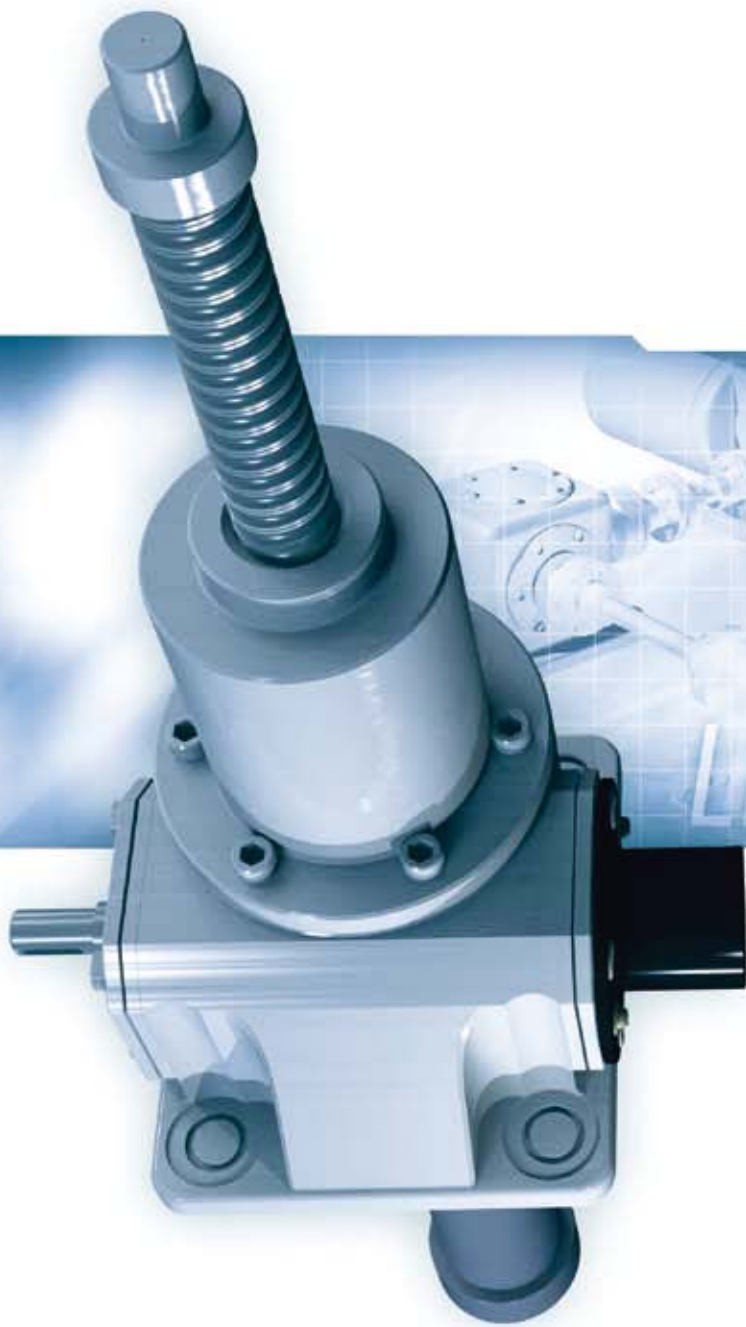

# Linipower Jack

Application	143
Basic specifications list	145
Model Features	147
Selecting · Technical Notes	148
Screw Shaft Speed and Allowable Load	153
Allowable Buckling Load	158
Expected Travel Distance	162
Technical Data	163
JWM	164
JWB	190
JWH	214
Options	228
Notes on Installation	250
Product Information	256



# Linipower Jack

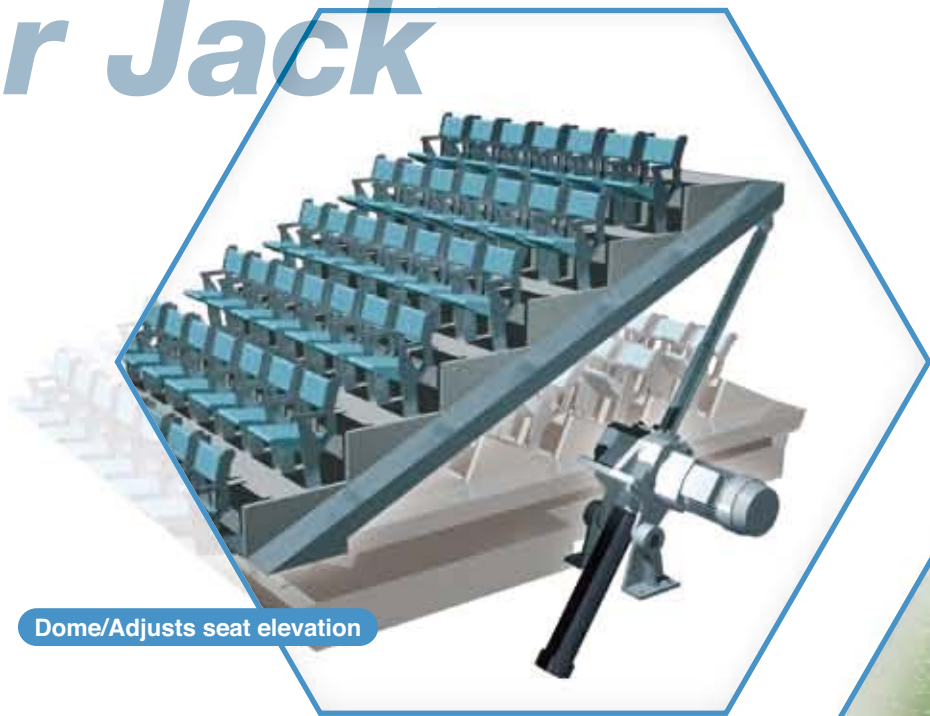

## APPLICATION SOLUTION

TSUBAKI E&M Linipower Jack is our latest jack realized through a combination of technology cultivated over years of experience as a top manufacturer of power cylinders and product manufacturing in consideration of thorough quality controls and environmental consciousness.

Linipower Jacks play an active role across various fields including iron and steel, stage setting, medical equipment, and liquid crystal /PDP devices.

In addition, specifications and options are offered for selection according to the variety of application and intended purpose.





Dome/Adjusts mound elevation

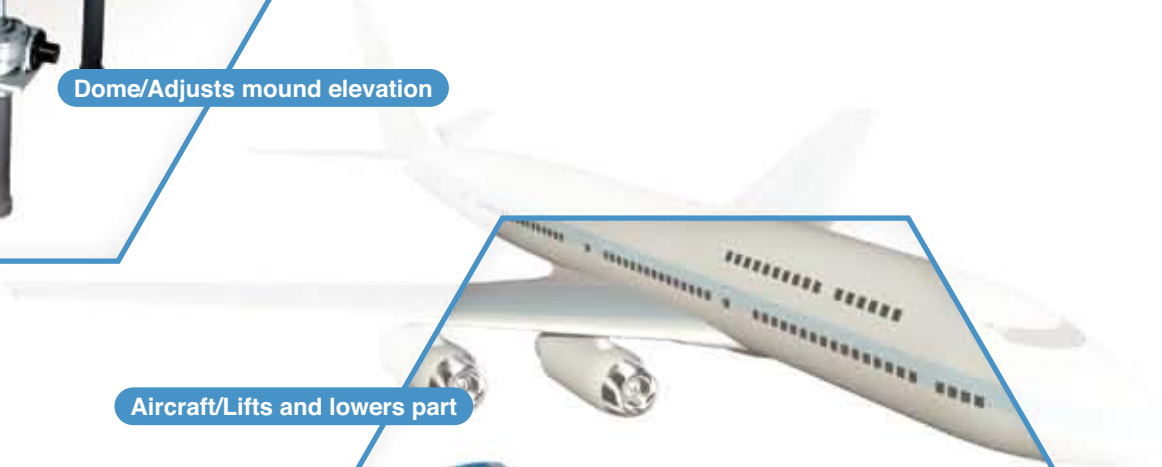
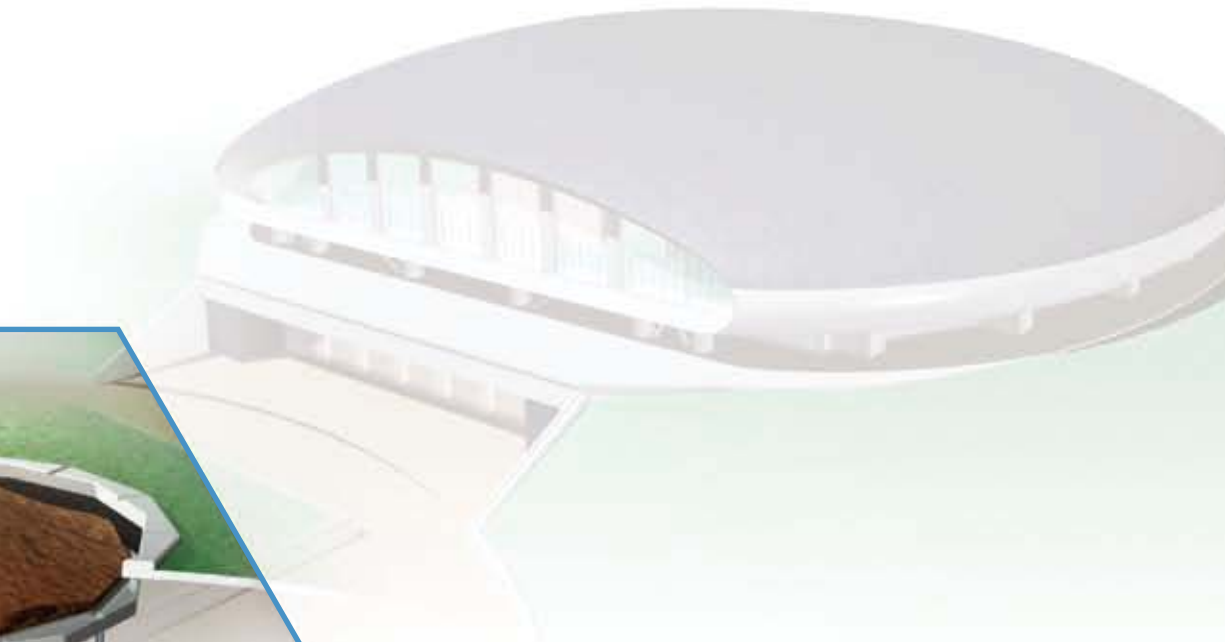

Aircraft/Lifts and lowers part



Parabolic Antenna/Adjusts antenna angles

# Linipower Jack

## Linipower Jack Basic specifications list

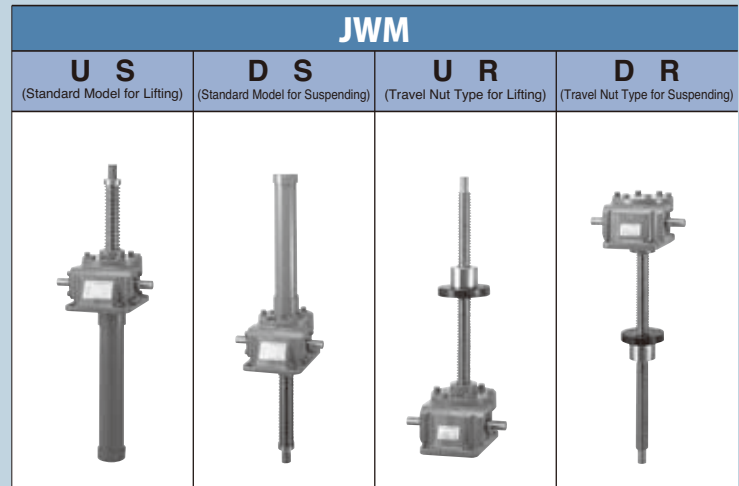

		JWM							
		U S (Standard Model for Lifting)		D S (Standard Model for Suspending)		U R (Travel Nut Type for Lifting)		D R (Travel Nut Type for Suspending)	
Standard	Frame No.	002~200	300~1000	002~200	300~1000	002~200			
	*1 Basic Capacity* kN {tf}	1.96~196	294~980	1.96~196	294~980	1.96~196			
	Screw Outer Diameter mm	12~65	85~150	12~65	85~150	{0.2}~{20}			
	Gear Ratio	H/L Speed							
	Stroke	See Table Below							
	Lubrication	Shaft: Grease Reducer Unit: Grease Bath							
	Color	Tsubaki Olive Grey (Munsell 5GY6/0.5)							
	Environment	Indoor							
*2 Rotation Prevention		○	△	○	△	×	×		
Output	Bellows	○	○	○	○	△	△		
	Rod Type End Fitting	○	○	○	○	×	×		
	I Type End Fitting	○	○	○	○	×	×		
	Table Type End Fitting	○	○	○	○	×	×		
Sensor	LS Counter	○	○	○	○	○	○		
	Internal LS x2	○	○	○	○	○	○		
	Internal LS x4	○	○	○	○	○	○		
	Potentiometer	○	○	○	○	○	○		
	Rotary Encoder	○	○	○	○	○	○		
Input	3 Phase Motor	△	△	△	△	△	△		
	Gearmotor	○	△	○	△	○	○		
	Hand Wheel	○	△	○	△	○	○		
Accessories	Clevis Fitting Adapter	○	△	△	△	△	△		
	Trunnion Fitting Adapter	○	△	△	△	△	△		

\*1 Basic capacity means a maximum load which the jack can support (retain).

\*2 Rotating force is generated on the screw shaft of the jack. Select anti-rotation specification if the screw shaft is free or there is no guide, etc., on the equipment side.

Frame No.		002	005	010	025	050	100	150	200	300	500	750	1000
Basic Capacity	kN	1.96	4.90	9.80	24.5	49.0	98.0	47	196	294	490	735	980
	{tf}	{0.2}	{0.5}	{1}	{2.5}	{5}	{10}	{15}	{20}	{30}	{50}	{75}	{100}
Stroke	100	○	○	○	○	○	○	○	○	△	△	△	△
	200	○	○	○	○	○	○	○	○	△	△	△	△
	300	○	○	○	○	○	○	○	○	△	△	△	△
	400	○	○	○	○	○	○	○	○	△	△	△	△
	500	△	○	○	○	○	○	○	○	△	△	△	△
	600	△	○	○	○	○	○	○	○	△	△	△	△
	800	—	○	○	○	○	○	○	○	△	△	△	△
	1000	—	△	○	○	○	○	○	○	△	△	△	△
	1200	—	—	△	○	○	○	○	○	△	△	△	△
	1500	—	—	—	△	○	○	○	○	△	△	△	△
2000	—	—	—	—	△	△	△	△	○	△	△	△	

Traveling nut specification is also available for JW300 and above.

○: Standard △: Produced by order —: Produced depending on the conditions of use. Consult with us. ×: Not producible

JWB						JWH				
U S (Standard Model for Lifting)		D S (Standard Model for Suspending)		U R (Travel Nut Type for Lifting)	DR (Travel Nut Type for Suspending)	U S (Standard Model for Lifting)		D S (Standard Model for Suspending)	U R (Travel Nut Type for Lifting)	DR (Travel Nut Type for Suspending)
005~200	300~1000	005~200	300~1000	005~200		010~200		010~200		
4.90~196	294~980	4.90~196	294~980	4.90~196		9.80~196		9.80~196		
{0.5}~{20}	{30}~{100}	{0.5}~{20}	{30}~{100}	{0.5}~{20}		{1}~{20}		{1}~{20}		
16~63	85~140	16~63	85~140	16~63		20~63		20~63		
H/L Speed						H Speed				
See Table Below						See Table Below				
Shaft: Grease Reducer Unit: Grease Bath						Shaft: Grease Reducer Unit: Grease Bath				
Tsubaki Olive Grey (Munsell 5GY6/0.5)						Tsubaki Olive Grey (Munsell 5GY6/0.5)				
Indoor						Indoor				
○	△	○	△	×	×	△	△	×	×	
○	○	○	○	△	△	○	○	△	△	
○	○	○	○	×	×	○	○	×	×	
○	○	○	○	×	×	○	○	×	×	
○	○	○	○	×	×	○	○	×	×	
○	○	○	○	○	○	○	○	○	○	
○	○	○	○	○	○	○	○	○	○	
○	○	○	○	○	○	○	○	○	○	
○	○	○	○	○	○	○	○	○	○	
○	△	○	△	○	○	△	△	△	△	
○	△	○	△	○	○	△	△	△	△	
△	△	△	△	△	△	△	△	△	△	
○	△	△	△	△	△	○	△	△	△	
○	△	△	△	△	△	○	△	△	△	

005	010	025	050	100	150	200	300	500	750	1000	010	025	050	100	150	200
4.90	9.80	24.5	49.0	98.0	147	196	294	490	735	980	9.80	24.5	49.0	98.0	147	196
{0.5}	{1}	{2.5}	{5}	{10}	{15}	{20}	{30}	{50}	{75}	{100}	{1}	{2.5}	{5}	{10}	{15}	{20}
○	○	○	○	○	○	○	△	△	△	△	○	○	○	○	○	○
○	○	○	○	○	○	○	△	△	△	△	○	○	○	○	○	○
○	○	○	○	○	○	○	△	△	△	△	○	○	○	○	○	○
○	○	○	○	○	○	○	△	△	△	△	○	○	○	○	○	○
○	○	○	○	○	○	○	△	△	△	△	○	○	○	○	○	○
○	○	○	○	○	○	○	△	△	△	△	○	○	○	○	○	○
△	○	○	○	○	○	○	△	△	△	△	○	○	○	○	○	○
-	△	○	○	○	○	○	△	△	△	△	△	○	○	○	○	○
-	-	△	○	○	○	○	△	△	△	△	-	△	○	○	○	○
-	-	-	△	△	△	○	△	△	△	△	-	-	△	△	△	○

# Linipower Jack

## Model Features

## JWM [Machine Screw Type]

### Low Speed, Low Frequency

JWM (Machine Screw Type) is a standard model, suitable for low speed, low frequency operations. Major components include trapezoidal screw and high precision worm gear.

#### 1. Economical

Simple, compact and affordable.

#### 2. Low Speed, Low Frequency

The unique sliding motion of trapezoidal screw provides smooth and consistent low speed, suitable for low frequency operations.

#### 3. Load

Machine screw has a self-lock feature based on calculation, and can maintain loads.

\* Self-lock may not be effective where vibration or shock is present. In this case, install a brake unit.



## JWB [Ball Screw Type]

### High Speed, High Frequency

JWB (Ball Screw Type) is a highly efficient jack for high speed, high frequency operations. Major components include accurate ball screw and high precision worm gear.

#### 1. High Efficiency

JWB's ball screw generates high efficiency and its compact drive unit produces high power.

#### 2. High Speed

Compared to the JWM, its high efficiency allows easier high speed drive.

#### 3. Extended Life

Long and predictable ball screw life.

\*Self-lock is not provided. Must install a brake unit.

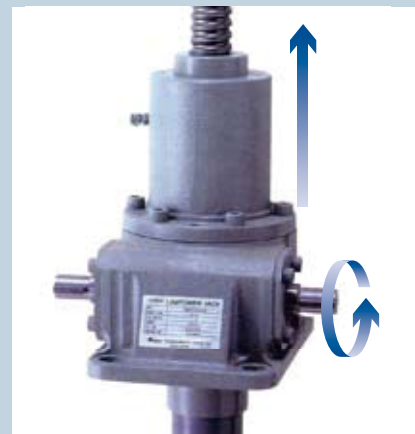

## JWH [High Lead Ball Screw Type]

### Super High Speed, High Frequency

Depending on the high lead ball screw used, the screw shaft speed can exceed that of a JWB by up to 4 times at the same input shaft rpm. Major components include high lead ball screw and high precision worm gear.

#### 1. Super High Speed

Effective high lead screw allows maximum screw shaft speed of 7.5m/min.

#### 2. Quiet Operation

JWH (High Lead Ball Screw Type) requires less input rpm at its drive and reducer units to run at the same speed of JWB (Ball Screw Type), resulting in considerably quiet operation.

\*Self-lock is not provided. Must install a brake unit.

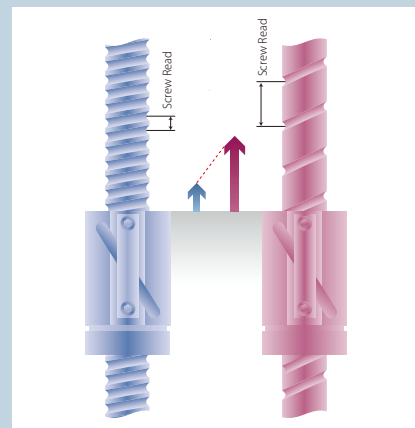

Linipower Jack

*Selecting Your Linipower Jack ·  
Technical Notes*

**Selecting Your Linipower Jack**

Selecting Process	P149•150
Example	P151•152

**Technical Notes**

Screw Shaft Speed and Allowable Load	P153~157
Allowable Buckling Load	P158~160
Allowable Side Load	P161
Expected Travel Distance and Wear Life	P162
Technical Data	P163
(Allowable OHL and Allowable Screw Shaft rpm)	



# Selecting Your Linipower Jack

## Selecting Process

- 1) **Equipment** . . . . . Table or theatre lifter, conveyer line selector etc.
- 2) **Layout** . . . . . Patterns of multiple jack systems (4, 6 or more units), driving, coupling etc.
- 3) **Maximum Load (W)** . . . . . Load or work weight N {kgf}.
- 4) **Screw Shaft Speed (V)** . . . . . Required speed for jack, m/min.
- 5) **Stroke** . . . . . Actual stroke used, mm.
- 6) **Screw Types** . . . . . Machine Screw Type (JWM), Ball Screw Type (JWB), High Lead Ball Screw Type (JWH).
- 7) **Installation Configuration** . . . . . Basic specifications (lift or suspend, with or without rotation prevention).  
Travel nut type (lift or suspend).
- 8) **Installation Conditions** . . . . . Fixed base, shaft end, clevis etc. For compression loads, consider buckling.
- 9) **Life Expectancy** . . . . . Years jack will withstand wear (for JWB, JWH only).

## STEP1 Selecting Your Linipower Jack

### 1. Adjusted Load Ws

Calculate the "Adjusted Load" Ws, by determining the correct safety coefficient rate (Table 1) for specific load conditions.

$$\text{Adjusted Load } W_s = \text{Maximum Load } W \times \text{Coefficient } S_f$$

N {kgf}                      N {kgf}

Table 1. Coefficient S<sub>f</sub>

Load Conditions	Example Purposes	Coefficient Range
Smooth movement with no shock Light load	Opening and closing a valve Adjusting a conveyor	1.0 ~ 1.3
Light shock Medium load	Use with various kinds of transporting equipment and lifters	1.3 ~ 1.5
Severe shock and/or vibration Heavy load	Use with large transporting carriages Holding the position of a press roller	1.5 ~ 3.0

Note) The above table is for general reference only. Consider particular operating conditions under which you operate before selecting a coefficient.

### 2. Load per jack

Calculate load W per jack, by using the adjusted load Ws obtained above.

For a synchronous drive, use a synchronous drive coefficient (Table 2).

$$\text{Load / jack } W = \frac{\text{Adjusted Load } W_s \text{ N\{kgf\}}}{\text{No. of jacks} \times \text{synchro. drive coefficient } f_d}$$

N {kgf}

Table 2. Synchronous Drive Coefficient f<sub>d</sub>

No. of units	2	3	4	5 ~ 8
Coefficient	0.95	0.9	0.85	0.8

### 3. Jack Selection

Follow these steps to make a preliminary jack selection.

#### Points of preliminary jack selection

- ① Select (temporary) worm speed ratio by adjusting the screw shaft rpm. If difficult to select, inspect by H speed.
- ② Consider traveling space when selecting stroke.
- ③ Select options based on your needs.

### 4. Verifying Buckling and Screw Shaft rpm

#### ① Allowable Buckling Load

For a compressive load, verify that it does not exceed the allowable buckling load (See pages 158~160). If it does, increase jack size and recalculate.

#### ② Allowable Screw Shaft rpm

If using a travel nut, verify that it does not exceed the allowable shaft rpm (See page 163). If it does, increase jack size and recalculate.

### 5. Confirming Required Input rpm

Determine the required input rpm, using the required screw shaft speed.

$$N = \frac{V}{\ell} \times R$$

N : Input rpm                      r/min  
V : Screw Shaft Speed          m/min  
ℓ : Screw Lead                      m  
R : Gear Ratio

### 6. Verifying Required Input Torque

Calculate required input torque.

$$T = \frac{W \times \ell}{2 \times \pi \times R \times \eta} + T_o$$

T : Required Input Torque    N · m {kgf·m}  
W : Lifting Load              N {kgf}  
ℓ : Screw Lead                m  
π : Circular Constant        3.14  
R : Gear Ratio  
η : Overall Efficiency  
T<sub>o</sub> : Tare Drag Torque        N · m {kgf·m}

\* For screw lead, gear ratio, overall efficiency and tare drag torque, see pages 169, 195 and 219. Take caution in selecting screw units. (8mm→0.008m)

### 7. Verifying Input Capacity

$$\text{SI Unit } P = \frac{T \times N}{9550}$$

$$\text{Gravitational Unit } P = \frac{T \times N}{974}$$

T : Required Input Torque    N · m {kgf·m}  
P : Required Input Load      kW  
N : Input rpm                      r/min

8. Allowable Overhang Load

If attaching a sprocket, gear, or belt to the input shaft, verify that the total weight is within the allowable overhang load. (See page 163) If not, increase jack size and recalculate.

9. Verifying Wear Life (JWB/JWH only)

Check if wear life is sufficient. (See page 162)  
 When increasing travel distance, increase jack size and recalculate.  
 \* Life cannot be calculated for JWM (Machine Screw Type).

10. Selecting Your Options

Select options that best suit your needs.

1. Output Option	2. Installation Option	} (See page 228~)
3. Sensor Option	4. Input Option	
5. Accessory Option		

11. Jack Number

Determine the actual Linipower Jack number that meets the above conditions.

STEP2 Parts Options

Motor

Determine the required drive unit capacity for synchronous drive Pt.

1. Add the torque required for each jack  $T_{1\sim4}$  on the drive unit side to determine the overall Torque  $T_t$ .

<Required Torque per Jack>

$$T_{1\sim4} = \frac{T}{(\text{Gearbox efficiency})^{\text{No. of gear box}}}$$

<Required Torque for the Drive Unit>

$$T_t = T_1 + T_2 + T_3 + T_4$$

$T_{1\sim4}$  : Required torque for each jack on the drive unit side  $N \cdot m \{kgf \cdot m\}$   
 $T$  : Required input torque per jack  $N \cdot m \{kgf \cdot m\}$   
 Gear box efficiency: Assume 0.9  
 $T_t$  : Required torque for the drive-unit  $N \cdot m \{kgf \cdot m\}$

For a four unit system (Fig. 1),  $T_{1\sim4} = \frac{T}{0.9^2}$

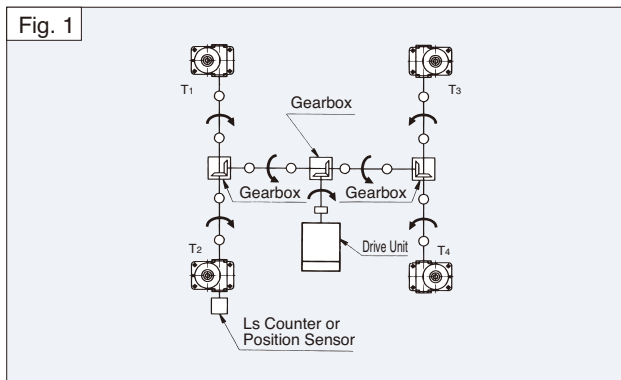

2. Be certain that the required input torque calculated is within the allowable input shaft torque.  
 (e.g.) If jacks are arranged in a linear structure as shown in Fig. 2, the drive unit input shaft consumes the total input torque required for both jacks. This doubled torque should not exceed the allowable input torque.

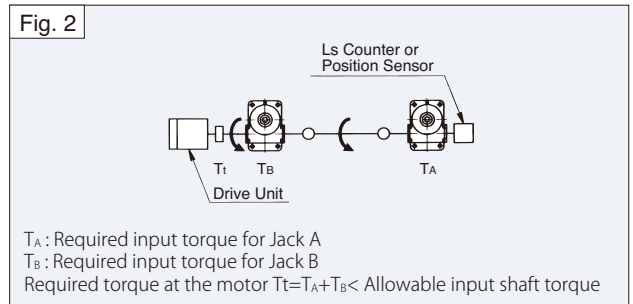

3. Next, determine the required drive unit capacity Pt with input rpm N and overall Torque  $T_t$  determined in 1.

SI Unit	$P_t = \frac{T_t \times N}{9550}$	$P_t$ : Total required torque at the drive unit kW
Gravitational Unit	$P_t = \frac{T_t \times N}{974}$	$T_t$ : Total required torque at the drive unit $N \cdot m \{kgf \cdot m\}$
		N : Input rpm for the jack r/min

Other Parts Options

- Gear box....Select based on input rpm and required torque.  
 See TSUBAKI E&M Miter Gear Box Catalog. (Bulletin No.04001)
- Coupling....Select based on allowable torque and maximum shaft diameter.  
 See TSUBAKI E&M Coupling Catalog. (Bulletin No.06009)

## Example

### Jack Selection Example 1

**Example :** Four jack synchronous drive for lifting with 3-phase 220v/60Hz motor (see layout below), operating at room temperature under low dust conditions.

Guide installed on the equipment to prevent side load.

Fixed base-Guided shaft end/Fixed shaft end.

Operation cycle : (2 times/hour) X (8 hours/day) X (300 days/year) X (3 years usage)

① Maximum load : 88.2 kN {9 tf} / 4 Units

② Required speed : 10 mm/s (600 mm/min)

③ Operating stroke : 260 mm

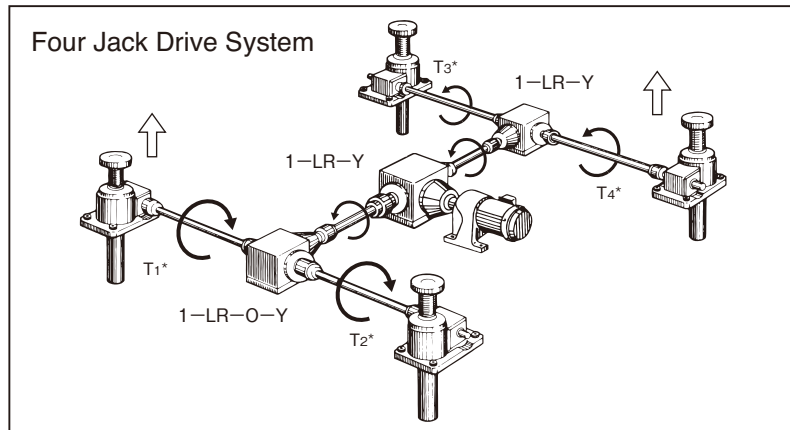

⌚ Jacks lift as rotational input is applied in the direction of each arrow.

\* See the previous page for  $T_1 \sim T_4$

#### SI Unit

1. Adjusted load  $W_s$  is (coefficient  $S_f=1.3$ )

$$W_s = 88200 \times 1.3 = 114660 \text{ N}$$

2. Load  $W$  per jack is

$$W = \frac{114660}{4 \times 0.85} = 33724 \text{ N}$$

3. Considering speed, efficiency and drive unit, JWB050USH is preliminarily selected.

4. For 260mm operating stroke, use 300 mm stroke for the jack.

Considering its possible dust generation and shaft end stability (see layout above), the appropriate jack would be JWB050USH3JM.

5. Since this load is compressive, calculate the operated buckling load based on the formula used on pages 159~160. (Assume safety level  $S_f=4$ .) See page 160 for details on calculations.

$$P_{CR} = 20 \times 10^4 \times \left( \frac{31.3^2}{637} \right)^2$$

\*Refer to dimensions on page 203.

$$= 473073 \text{ N}$$

$$S_f = \frac{473073}{33724} > 4 \cdots \text{OK}$$

6. This is not a travel nut type so there is no need to confirm allowable screw shaft rpm. (Inspect the allowable screw shaft rpm if using a travel nut.)

#### { Gravitational Unit }

1. Adjusted load  $W_s$  is (coefficient  $S_f=1.3$ )

$$W_s = 9000 \times 1.3 = 11700 \text{ kgf}$$

2. Load  $W$  per jack is

$$W = \frac{11700}{4 \times 0.85} = 3442 \text{ kgf}$$

3. Considering speed, efficiency and drive unit, JWB050USH is preliminarily selected.

4. For 260mm operating stroke, use 300 mm stroke for the jack. Considering its possible dust generation and shaft end stability (see layout above), the appropriate jack would be JWB050USH3JM.

5. Since this load is compressive, calculate the operated buckling load based on the formula used on pages 159~160. (Assume safety level  $S_f=4$ .) See page 160 for details on calculations.

$$P_{CR} = 20 \times 10^3 \times \left( \frac{31.3^2}{637} \right)^2$$

\*Refer to dimensions on page 203.

$$= 47307 \text{ kgf}$$

$$S_f = \frac{47307}{3442} > 4 \cdots \text{OK}$$

6. This is not a travel nut type so there is no need to confirm allowable screw shaft rpm. (Inspect the allowable screw shaft rpm if using a travel nut.)

### SI Unit

#### 7. Required Input Capacity

$$\textcircled{1} N = \frac{0.60}{0.010} \times 6 = 360 \text{ r/min}$$

$$\textcircled{2} T = \frac{33724 \times 0.010}{2 \times 3.14 \times 6 \times 0.64} + 1.37 = 15.4 \text{ N} \cdot \text{m}$$

$$\text{From } \textcircled{1}\textcircled{2} \quad P = \frac{15.4 \times 360}{9550} = 0.58 \text{ kW}$$

Rated input capacity for JWB050USH3 is 0.58 kW < 2.2 kW.  
(If not suitable, increase the frame number or reduce the screw shaft rpm and recalculate.)

8. Overhang load does not apply so inspection is not required. Inspect as appropriate.

#### 9. Verifying Wear Life for JWB

Calculate the expected travel distance from usage frequency. (See page 162)

Expected driving distance =  $0.26 \times 2 \times 8 \times 300 \times 10^{-3} \times 3 = 3.74 \text{ km}$

We then find that the suitable jack number is JWB050.

.....OK

#### 10. Jack Options

Possible dust  $\longrightarrow$  Use with bellow

Shaft end  $\longrightarrow$  Table shaft end

Finally, we conclude by selecting **JWB050USH3JM**.

### { Gravitational Unit }

#### 7. Required Input Capacity

$$\textcircled{1} N = \frac{0.60}{0.010} \times 6 = 360 \text{ r/min}$$

$$\textcircled{2} T = \frac{3442 \times 0.010}{2 \times 3.14 \times 6 \times 0.64} + 0.14 = 1.57 \text{ kgf} \cdot \text{m}$$

$$\text{From } \textcircled{1}\textcircled{2} \quad P = \frac{1.57 \times 360}{974} = 0.58 \text{ kW}$$

Rated input capacity for JWB050USH3 is 0.58 kW < 2.2 kW.  
(If not suitable, increase the frame number or reduce the screw shaft rpm and recalculate.)

8. Overhang load does not apply so inspection is not required. Inspect as appropriate.

#### 9. Verifying Wear Life for JWB

Calculate the expected travel distance from usage frequency. (See page 162)

Expected driving distance =  $0.26 \times 2 \times 8 \times 300 \times 10^{-3} \times 3 = 3.74 \text{ km}$

We then find that the suitable jack number is JWB050.

.....OK

#### 10. Jack Options

Possible dust  $\longrightarrow$  Use with bellow

Shaft end  $\longrightarrow$  Table shaft end

Finally, we conclude by selecting **JWB050USH3JM**.

### Selecting Parts (Parts Options)

#### A. Selecting a Drive Unit

1. Calculate the required torque  $T_1$  (2.3.4) for each jack on the drive unit side.

$$\text{SI Unit} \quad T_1 = \frac{15.4}{0.9^2} = 19.0 \text{ N} \cdot \text{m}$$

$$\left\{ \begin{array}{l} \text{Gravitational} \\ \text{Unit} \end{array} \right. T_1 = \frac{1.57}{0.9^2} = 1.94 \text{ kgf} \cdot \text{m}$$

Since 4 jacks follow the same route

$$\text{SI Unit} \quad T_t = T_1 \times 4 = 76.0 \text{ N} \cdot \text{m}$$

$$\left\{ \begin{array}{l} \text{Gravitational Unit} \end{array} \right. T_t = T_1 \times 4 = 7.76 \text{ kgf} \cdot \text{m}$$

#### 2. Inspecting the Rated Input Torque

In this case, inspection is not necessary because 2 or more jacks are not arranged in a linear structure.

#### 3. Required Capacity for the Drive Unit $P_t$

$$\text{SI Unit} \quad P_t = \frac{76.0 \times 360}{9550} = 2.87 \text{ kW}$$

$$\left\{ \begin{array}{l} \text{Gravitational} \\ \text{Unit} \end{array} \right. P_t = \frac{7.76 \times 360}{974} = 2.87 \text{ kW}$$

from the input rpm 360r/min we find

$$\frac{1800}{360} = 5$$

Based on this data we select GMTA370-50L5B, TSUBAKI E&M 3.7kW gearmotor with a brake unit.

For details, see TSUBAKI E&M Compact Gearmotor Catalog (Bulletin No.07003).

B.1. Select a gear box based on the required input torque of  $15.4 \text{ N} \cdot \text{m}$  {  $1.57 \text{ kgf} \cdot \text{m}$  }, and input rpm of 360r/min.

1.1. Gear box on each side of the jack must tolerate the combined torque of 2 jacks. Thus we selected gear box ED4M.

$$\frac{15.4 \times 2}{0.9} = 34.3 \text{ N} \cdot \text{m} \quad \left\{ \begin{array}{l} \frac{1.57 \times 2}{0.9} = 3.49 \text{ kgf} \cdot \text{m} \end{array} \right.$$

(Caution: Make sure the direction of the gear box shaft rotation is correct.)

1-2. Gear box by the gearmotor requires torque for 4 jacks

$$\frac{15.4 \times 4}{0.9^2} = 76.1 \text{ N} \cdot \text{m} \quad \left\{ \begin{array}{l} \frac{1.57 \times 4}{0.9^2} = 7.76 \text{ kgf} \cdot \text{m} \end{array} \right.$$

From this, we find that the gear box ED6M is most suitable.

Gear box by the jack Left  $\longrightarrow$  ED4M 1-LR-O-Y

Right  $\longrightarrow$  ED4M 1-LR-Y

Gear box by the gearmotor  $\longrightarrow$  ED6M 1-LR-Y

(For details see TSUBAKI E&M Miter Gear Box Catalog).

#### B.2. Select couplings based on your requirements.

(See TSUBAKI E&M Coupling Catalog for details.)

The following is an example process for selecting the right couplings.

2-1. Select couplings used between each jack and their adjacent gear box based on the required input torque per jack,  $15.4 \text{ N} \cdot \text{m}$  {  $1.57 \text{ kgf} \cdot \text{m}$  }, input shaft diameter ( $\phi 20$  for JWB050USH), and the gear box shaft diameter ( $\phi 19$  for ED4M).

Required number is  $2 \times 2 = 4$ .

2-2. Select couplings used between the gear boxes based on the required torque for the nearest pair of jacks,

$$\frac{15.4 \times 2}{0.9} = 34.3 \text{ N} \cdot \text{m} \quad \left\{ \begin{array}{l} \frac{1.57 \times 2}{0.9} = 3.49 \text{ kgf} \cdot \text{m} \end{array} \right.$$

and the diameter of each gear box shaft: one by the jack ( $\phi 19$  for ED4M), and the other by the gearmotor ( $\phi 25$  ED6M). Required number is  $2 \times 2 = 4$ .

2-3. Select couplings used between each gear box and the gearmotor based on the total required torque for the four jacks,

$$\frac{15.4 \times 4}{0.9^2} = 76.1 \text{ N} \cdot \text{m} \quad \left\{ \begin{array}{l} \frac{1.57 \times 4}{0.9^2} = 7.76 \text{ kgf} \cdot \text{m} \end{array} \right.$$

and the diameters of the gear box ( $\phi 25$  for ED6M) and the output shafts ( $\phi 50$  for GMTA370-50L5B).

## Screw Shaft Speed (Lifting) and Allowable Load for JWM (Machine Screw Type)

This graph illustrates the relationship between screw shaft speed and allowable load for each frame number. Use this graph to select the correct frame number for specific requirements.

If inspection is required, see page 149 for calculation details.

### ■ H Speed

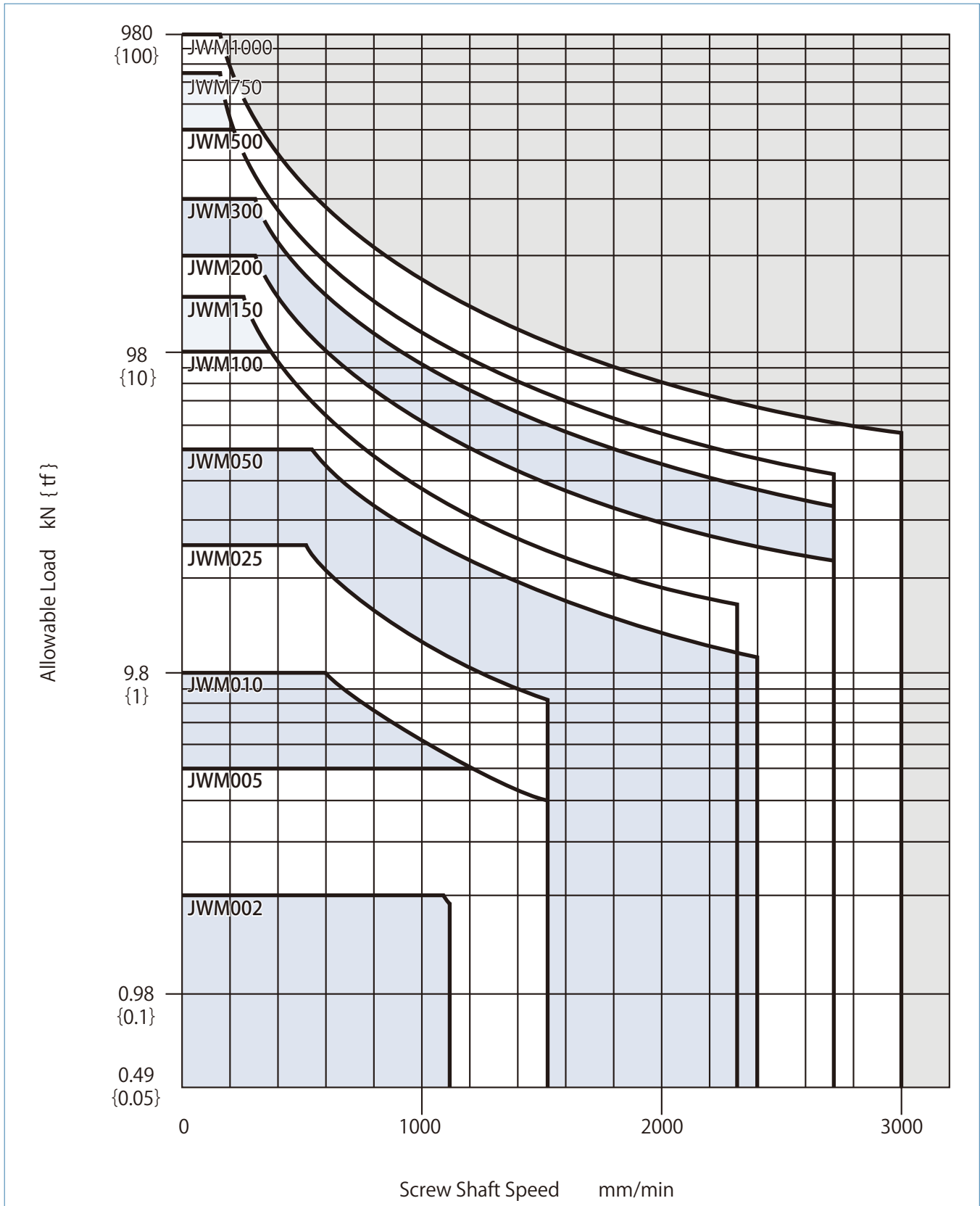

■ L Speed

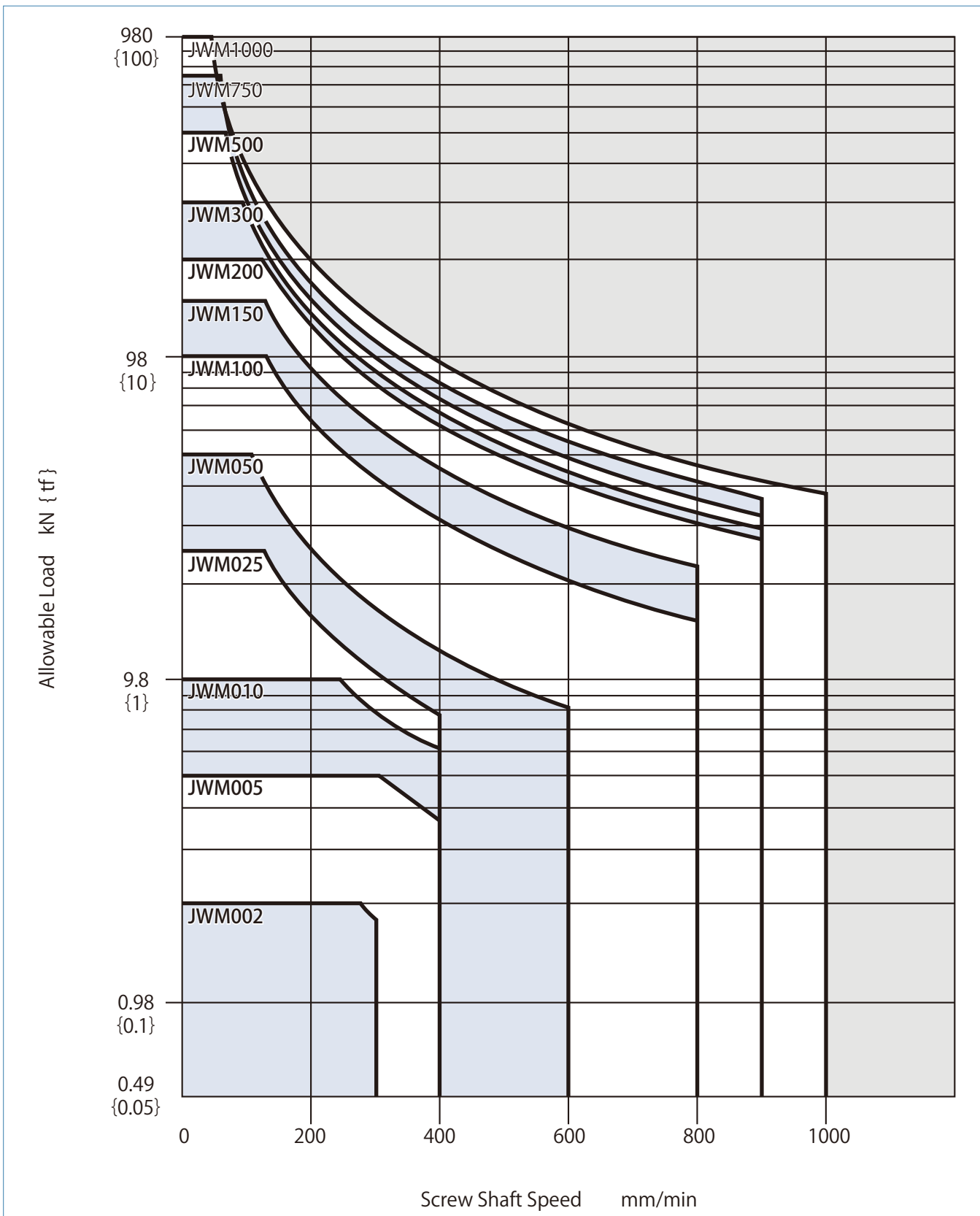



## Screw Shaft Speed (Lifting) and Allowable Load for JWB (Ball Screw Type)

This graph illustrates the relationship between screw shaft speed and allowable load for each frame number. Use this graph to select the correct frame number for specific requirements.

If inspection is required, see page 149 for calculation details.

### ■ H Speed

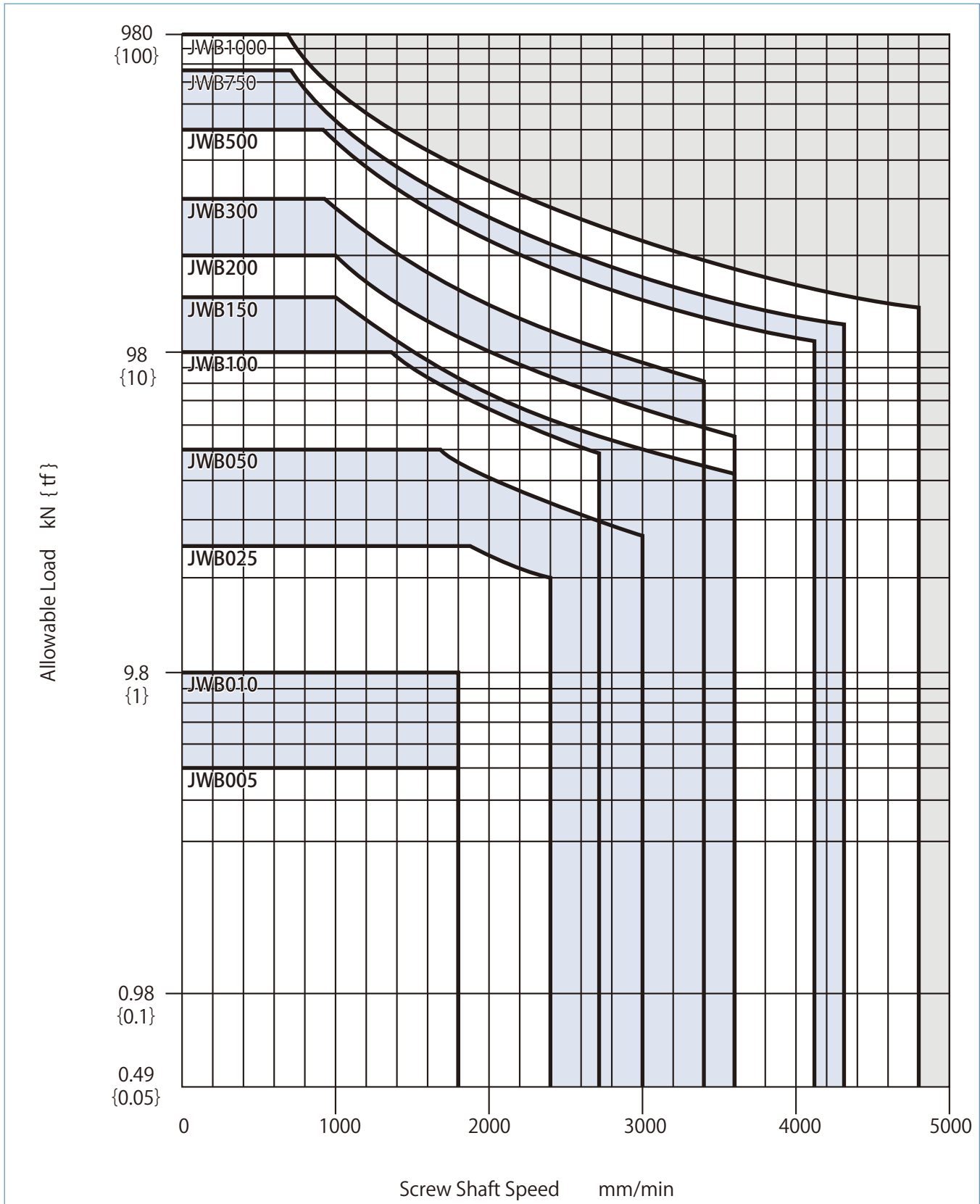

■ L Speed

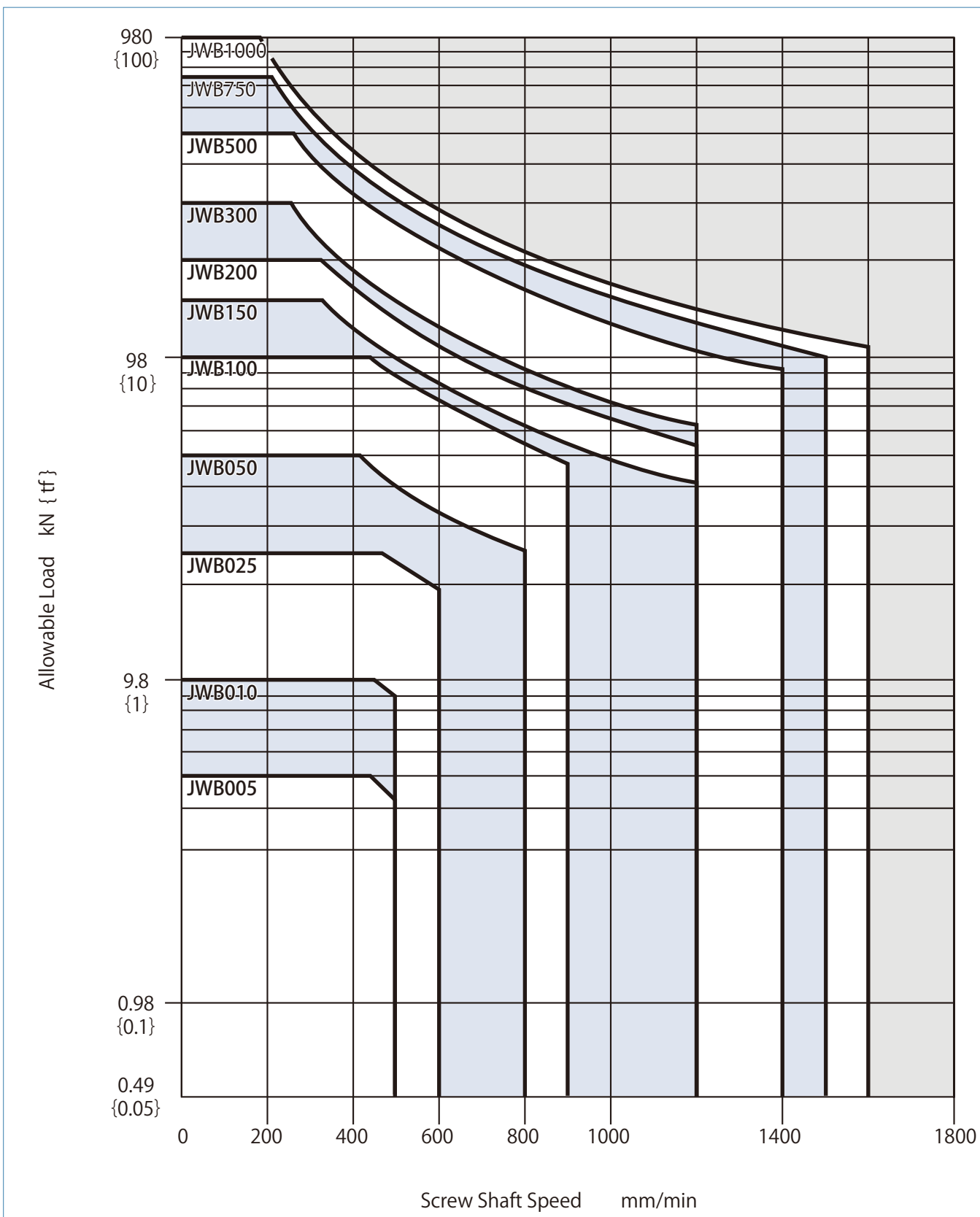

## Screw Shaft Speed (Lifting) and Allowable Load for JWH (High Lead Ball Screw Type)

This graph illustrates the relationship between screw shaft speed and allowable load for each frame number. Use this graph to select the correct frame number for specific requirements.

If inspection is required, see page 149 for calculation details.

### ■ H Speed

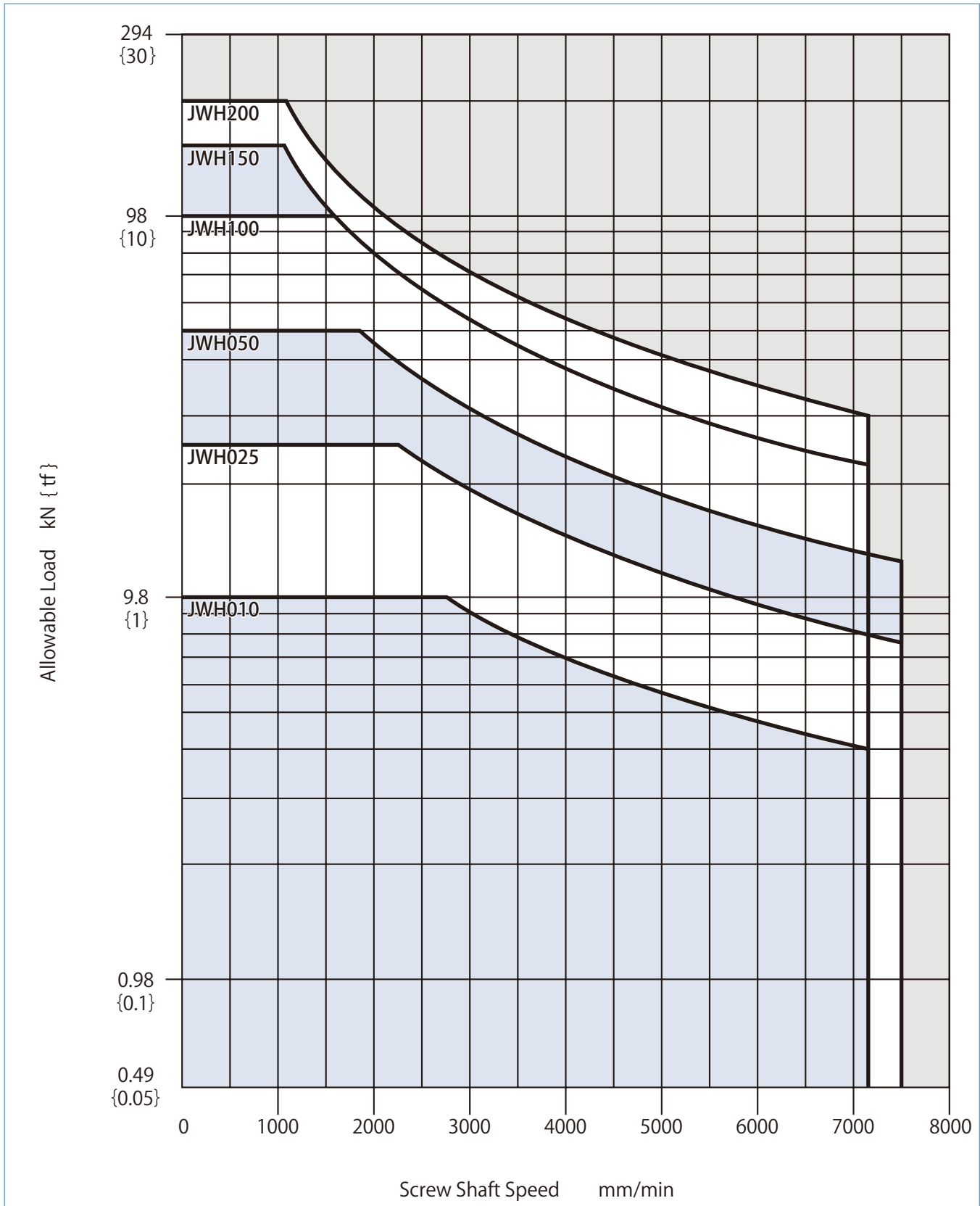

## Allowable Buckling Load for JWM (Machine Screw Type)

- Use this graph to select the correct frame number based on a specific buckling load, for compression loads.  
The graph for Allowable Buckling Load assumes a load safety rate of  $S_f = 4$ .
- ① From the installation conditions shown in A and C below, determine the correct distance for  $L_A$  and  $L_C$ .  
(For other installation conditions, see page 160)
- ② The graphs allow you to select the correct frame number based on a specific load  $W$  (vertical axis) and stroke distance  $L_A$  (horizontal axis).
- Make sure side load does not apply. The graph below assumes no side load.
- If the shaft is loaded in tension buckling can be avoided, and hence be highly economical.

### A Fixed base - Shaft end free

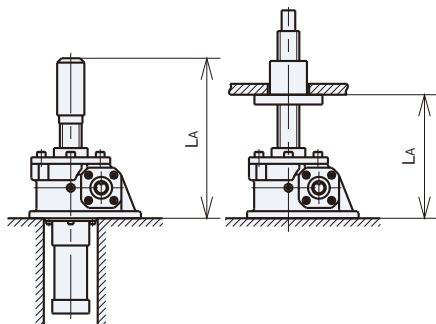

### C Fixed base - Guided shaft end/Fixed shaft end

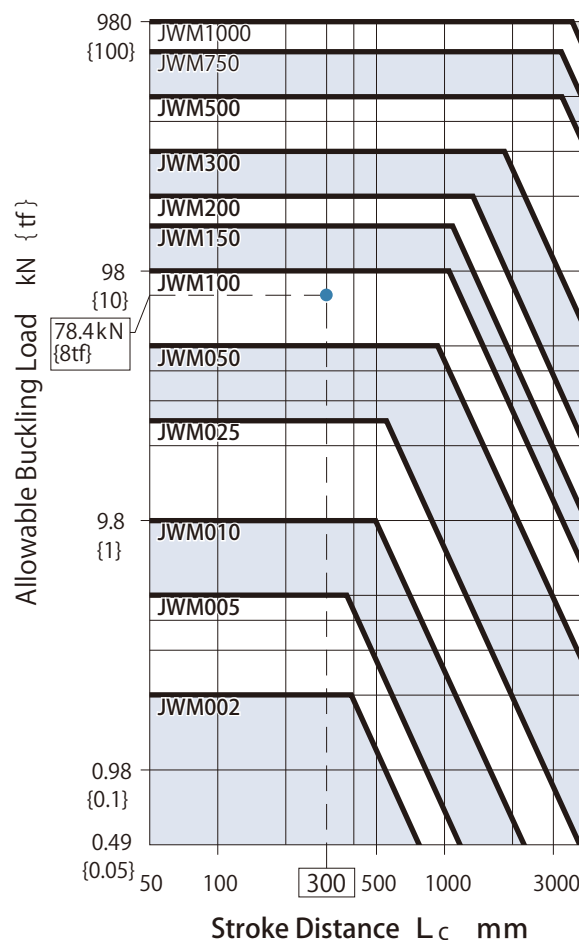
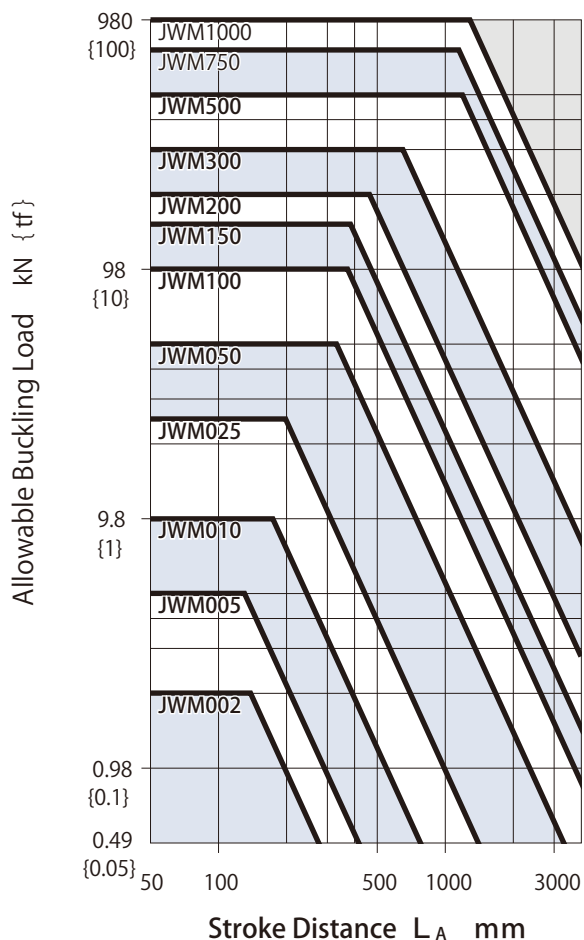
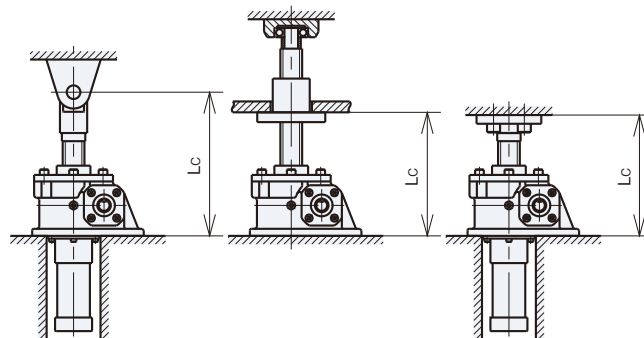

- Notes) 1. The dotted line on the graph represents an example based on  $W 78.4\text{kN} \{8\text{tf}\}$  load (buckling safety rate of  $S_f = 4$ ) and installation condition C with a distance of 300mm. From this graph, JWM100 is selected as the suitable frame number for these conditions.
2. If full inspection is required, see page 160 for calculation details.

## Allowable Buckling Load for JWB (Ball Screw Type)

- Use this graph to select the correct frame number based on a specific buckling load, for compression loads. The graph for Allowable Buckling Load assumes a buckling load safety rate of  $S_f = 4$ .
  - ① From the installation conditions shown in A and C below, determine the correct distance for  $L_A$  and  $L_C$ . (For other installation conditions, see page 160)
  - ② The graphs allow you to select the correct frame number based on a specific load  $W$  (vertical axis) and stroke distance  $L_A$  (horizontal axis).
- Make sure side load does not apply. The graph below assumes no side load.
- If the shaft is loaded in tension buckling can be avoided, and hence be highly economical.

### A Fixed base - Shaft end free

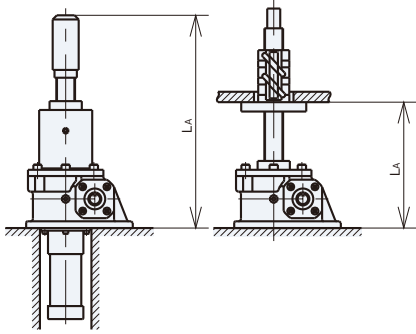

### C Fixed base - Guided shaft end/Fixed shaft end

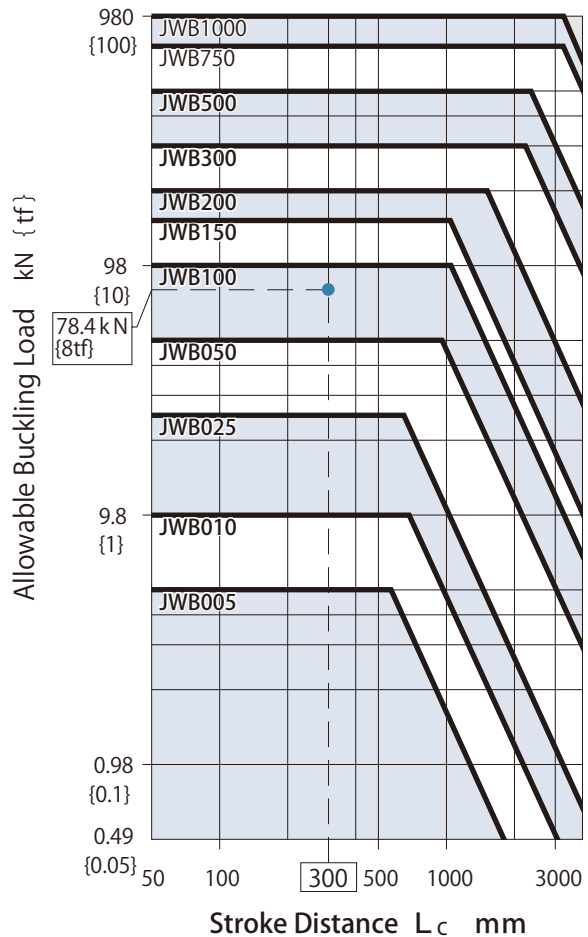
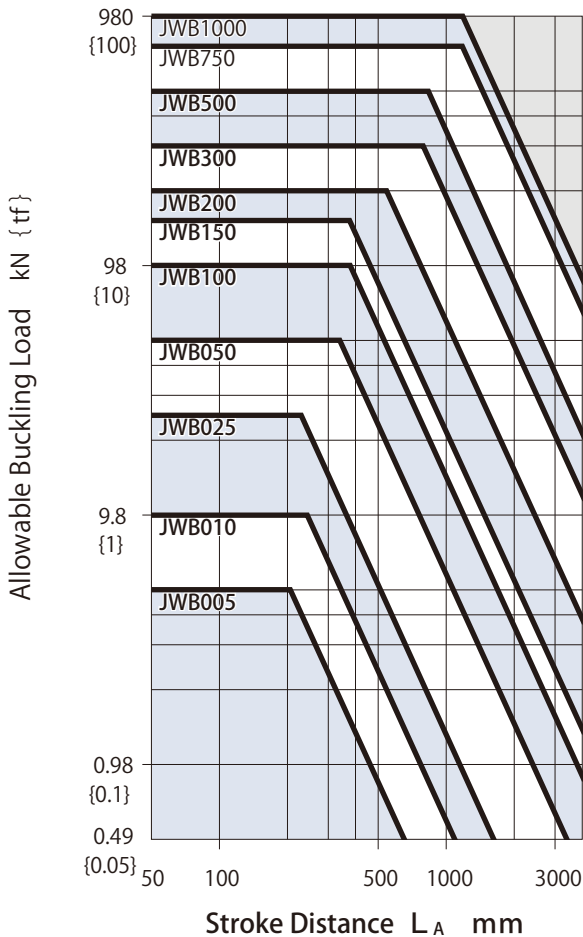
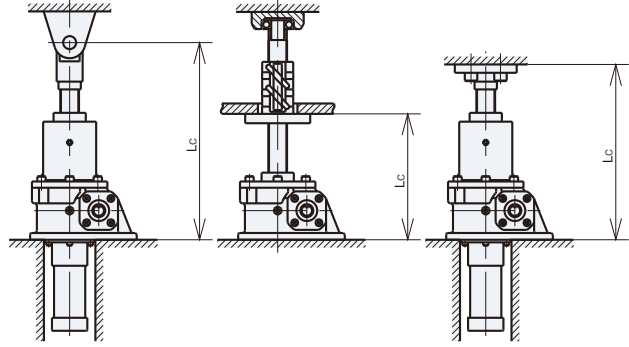

Notes) 1. The dotted line on the graph represents an example based on  $W 78.4 \text{ kN } \{8 \text{ tf}\}$  load (buckling safety rate of  $S_f = 4$ ) and installation condition C with a distance of 300mm. From this graph, JWB100 is selected as the suitable frame number for these conditions.

2. If full inspection is required, see page 160 for calculation details.

## Allowable Buckling Load for JWH (High Lead Ball Screw Type)

● Use this graph to select the correct frame number based on a specific buckling load for compression loads.

The graph for Allowable Buckling Load assumes a buckling load safety rate of  $S_f = 4$ .

- ① From the installation condition shown in C below, determine the correct distance for  $L_c$ . (For other installation conditions, see technical data).
- ② The graph allows you to select the correct frame number based on a specific load  $W$  (vertical axis) and stroke distance  $L_c$  (horizontal axis).

- Make sure side load does not apply. The graph below assumes no side load.
- If the shaft is loaded in tension buckling can be avoided, and hence be highly economical.

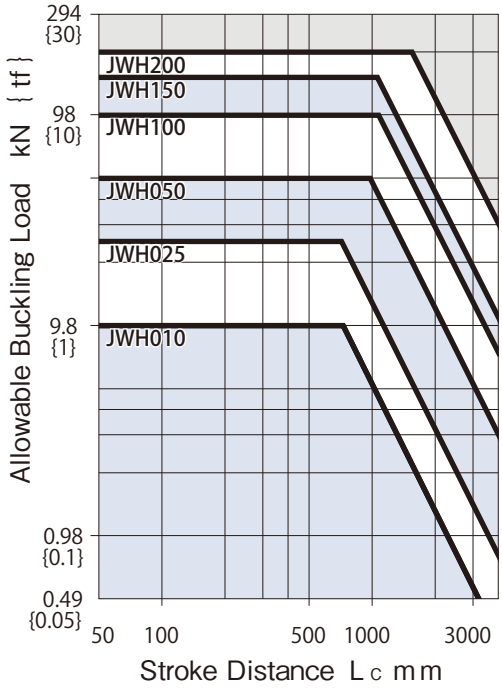

### C Fixed base - Guided shaft end/Fixed shaft end

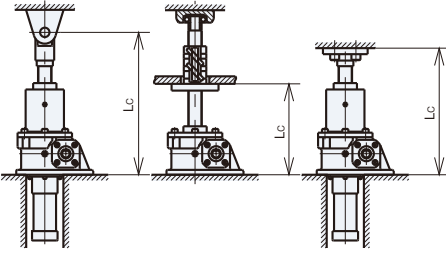

Note) If a detailed study is required, check by the following formula.

## Formula used to calculate Allowable Buckling Load

Formula used to calculate allowable buckling load.

$$P_{CR} = m \times \left( \frac{d^2}{L} \right)^2$$

Make sure  $P_{CR} > W \times S_f$

- $P_{CR}$  : Allowable buckling load N { kgf }
- $d$  : Screw shaft root diameter mm (Refer to pages 169 • 170 for JWM, pages 195 • 196 for JWB and pages 219 • 220 for JWH)
- $m$  : Support coefficient  
(Select installation condition from the figures below)
- $L$  : Screw shaft projection distance mm  
(maximum dimension in the dimensions table of each frame No.:  
If an end fitting is required, see the dimension of the end fitting.)
- $W$  : Load per jack N { kgf }
- $S_f$  : Buckling safety rate (Assume 4)

### ■ Installation Conditions

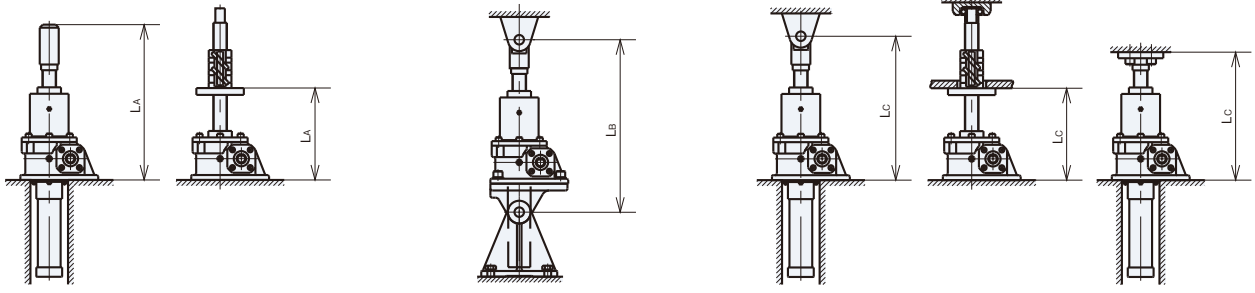

#### A Fixed base-Shaft end free

m	
SI Unit	$2.5 \times 10^4$
Gravitational Unit	$2.5 \times 10^3$

#### B Base and shaft end with clevis

m	
SI Unit	$10 \times 10^4$
Gravitational Unit	$10 \times 10^3$

#### C Fixed base-Guided shaft end/Fixed shaft end

m	
SI Unit	$20 \times 10^4$
Gravitational Unit	$20 \times 10^3$

### SI Unit

We calculate the  $P_{CR}$  of JWM100USH5JI, based on 49000N load and installation condition C (Fixed base and guided shaft end/Fixed shaft end.)

$$P_{CR} = 20 \times 10^4 \times \left( \frac{38.4^2}{791^*} \right)^2$$

$$= 695027 \text{ N}$$

$W \times S_f = 49000 \times 4$  (assuming  $S_f=4$ )  
 $= 196000 \text{ N}$   
 $P_{CR} > W \times S_f$       \*  $L=711+80$  (I-type end fitting)=791  
 from the dimensions table on page 181.

695027 > 196000...OK

### { Gravitational Unit }

We calculate the  $P_{CR}$  of JWM100USH5JI, based on 5000kgf load and installation condition C (Fixed base and guided shaft end/Fixed shaft end.)

$$P_{CR} = 20 \times 10^3 \times \left( \frac{38.4^2}{791^*} \right)^2$$

$$= 69502 \text{ kgf}$$

$W \times S_f = 5000 \times 4$  (assuming  $S_f=4$ )  
 $= 20000 \text{ kgf}$   
 $P_{CR} > W \times S_f$       \*  $L=711+80$  (I-type end fitting)=791  
 from the dimensions table on page 181.

69502 > 20000...OK



## Allowable Side Load for JWM (Machine Screw Type)

Guides are typically used for Machine Screw Types as shown in the diagram below. However, if the shaft projection distance (L) beyond the housing surface is relatively short, a certain amount of side load is acceptable.

Note) L represents the distance of screw shaft projection that affects side load. It does not refer to stroke distance.

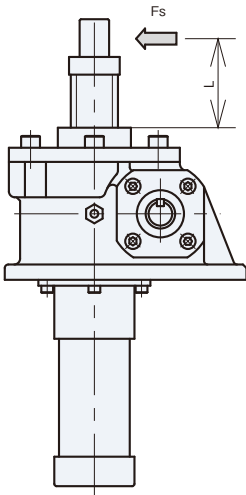

Frame Number Screw Shaft Projection Distance L, mm	Allowable Side Load											
	002	005	010	025	050	100	150	200	300	500	750	1000
100	83	128	318	570	2,500	4,010	4,610	8,210	21,700	85,300	73,500	159,700
	{9}	{13}	{32}	{59}	{255}	{409}	{470}	{838}	{2,210}	{8,700}	{7,500}	{16,300}
200	42	64	159	290	1,250	2,010	2,300	4,110	10,800	50,400	56,700	79,900
	{4}	{7}	{16}	{29}	{128}	{205}	{235}	{419}	{1,110}	{5,150}	{5,780}	{8,150}
300	28	43	106	190	830	1,340	1,540	2,740	7,200	33,600	37,800	53,200
	{3}	{4}	{11}	{20}	{85}	{136}	{157}	{279}	{740}	{3,430}	{3,860}	{5,430}
400	21	32	79	140	620	1,000	1,150	2,050	5,400	25,200	28,300	39,900
	{2}	{3}	{8}	{15}	{64}	{102}	{118}	{210}	{550}	{2,570}	{2,890}	{4,080}
500	—	27	64	110	500	800	920	1,640	4,300	20,200	22,700	31,900
	—	{3}	{6}	{12}	{51}	{82}	{94}	{168}	{440}	{2,060}	{2,310}	{3,260}
600	—	25	53	100	420	670	770	1,370	3,600	16,800	18,900	26,600
	—	{3}	{5}	{10}	{43}	{68}	{78}	{140}	{370}	{1,720}	{1,930}	{2,720}
700	—	23	51	90	360	570	660	1,170	3,100	14,400	16,200	22,800
	—	{2}	{5}	{9}	{36}	{58}	{67}	{120}	{320}	{1,470}	{1,650}	{2,330}
800	—	21	48	90	310	500	580	1,030	2,700	12,600	14,200	20,000
	—	{2}	{5}	{9}	{32}	{51}	{59}	{105}	{280}	{1,290}	{1,450}	{2,040}
900	—	—	45	90	280	450	510	910	2,400	11,200	12,600	17,700
	—	—	{5}	{9}	{28}	{45}	{52}	{93}	{250}	{1,140}	{1,290}	{1,810}
1000	—	—	42	90	250	400	460	820	2,200	10,100	11,300	16,000
	—	—	{4}	{9}	{26}	{41}	{47}	{84}	{220}	{1,030}	{1,160}	{1,630}

## Allowable Side Load for JWB and JWH (Ball Screw and High Lead Ball Screw Types)

If side load applies, make consideration so that it does not directly apply the jack by installing a guide as shown below.

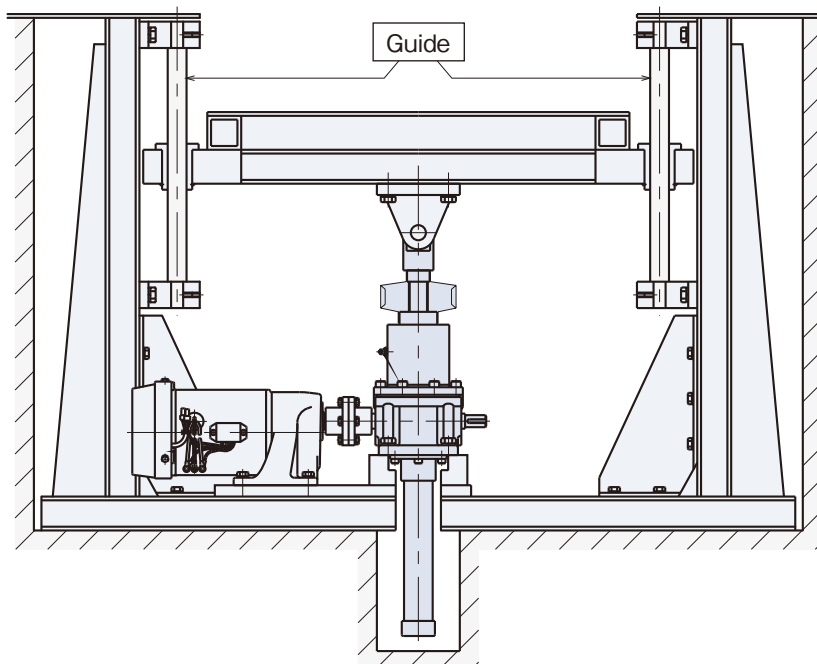

## Expected Travel Distance for JWB and JWH (Ball Screw and High Lead Ball Screw Types)

Ball screw life is determined by the flaking of the rolling surface due to fatigue.

Verify ball screw life expectancy using the graphs shown. However, note that conditions such as severe shock and failure to conduct regular maintenance can largely affect the life of a ball screw.

$$\text{Expected travel distance (km)} = \text{Actual load stroke (m)} \times \text{Usage frequency (times/day)} \times \text{No. of operating days/yr.} \times 10^{-3} \times \text{Expected no. of years}$$

The graph on the right is based on life expectancy of B10. B10 represents distance traveled by 90% of the entire unit.

If selecting a jack based on life, use the following graph and determine the frame number first.

Each graph shows the equivalent P<sub>m</sub> or 39.2kN {4tf} for the required expected travel distance, 5km. The coordinates of horizontal and vertical axes suggest suitable frame numbers. In this case, jacks JWB050, JWH050 or above are recommended.

If the load largely fluctuates in the middle of a stroke, use the following formula to calculate equivalent load.

$$P_M = \frac{P_{MIN} + 2 \times P_{MAX}}{3}$$

P<sub>M</sub> : Equivalent load kN { kgf }

P<sub>MIN</sub> : Minimum load kN { kgf }

P<sub>MAX</sub> : Maximum load kN { kgf }

<JWM (Machine Screw Type) Expected Travel Distance>  
Machine screw life cannot be determined by the formula used to calculate a ball screw wear life. Use the information below as a reference.  
  
JWM050 and below---5km (Average expected life)  
JWM100 and above---1km (Average expected life)

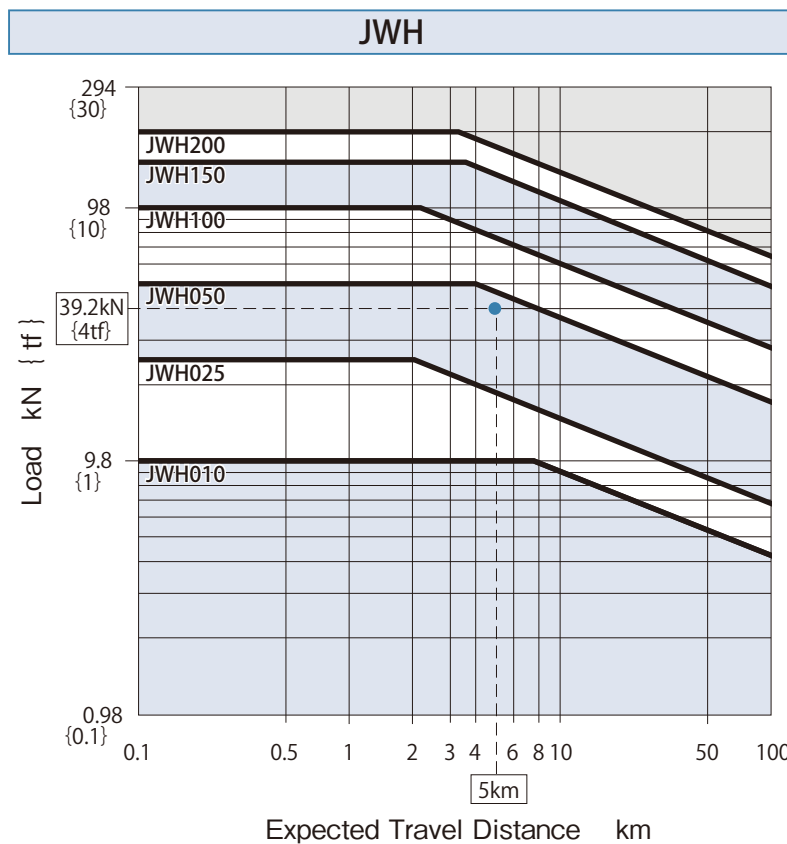
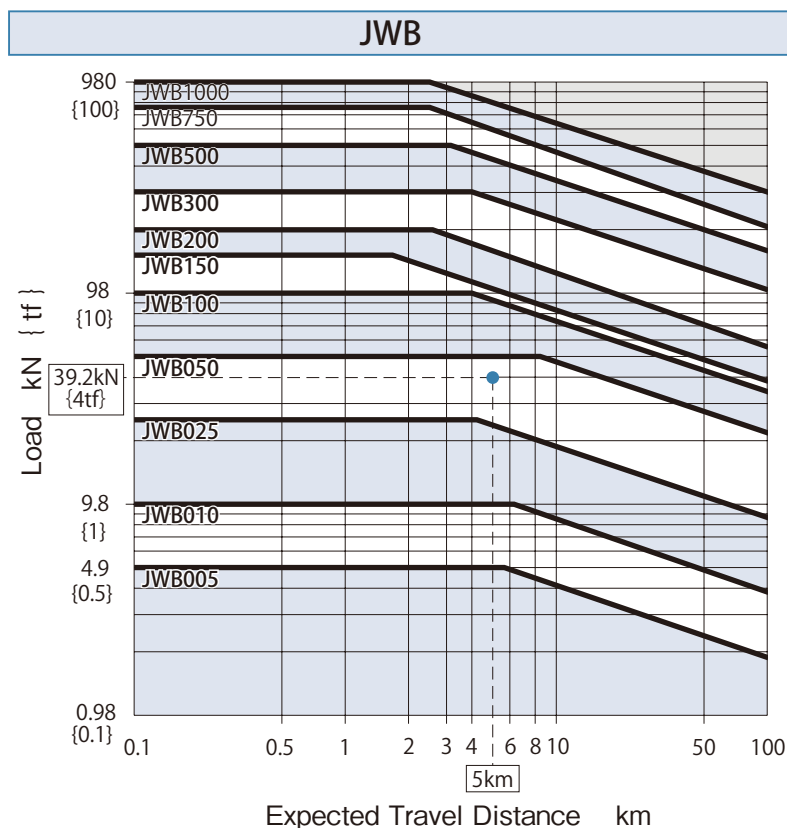

## 1. Allowable Overhang Load

When installing a sprocket, gear, or belt, use the following formula to verify that any overhang load applied to the shaft falls within the allowable OHL (Table 1).

$$\text{Allowable O. H. L.} \geq \frac{T \times f \times L_f}{R}$$

O.H.L. : Overhang load N {kgf}  
 T : Input torque N · m {kgf · m}  
 f : Coefficient - power transmission element  
 L<sub>f</sub> : Coefficient-Load position  
 R : Sprocket, Gear, V pulley or Pitch diameter m

Table 2. Coefficient- Power Transmission Element ( f )

Chain	1.00
Gear	1.25
V Belt	1.50
Flat Belt	2.50

Table 3. Coefficient (L<sub>f</sub>) - Load Position

L/Q	Below 0.5	0.75	1
L <sub>f</sub>	1	1.5	2

Table 1. Allowable O.H.L.

Frame No.		002	005	010	025	050	100	150	200	300	500	750	1000
JWM (Machine Screw Type) H Speed	N	99	200	380	710	1500	2270	3160	4320	6110	10100	13900	18000
	{ kgf }	{10}	{21}	{39}	{73}	{153}	{232}	{323}	{441}	{624}	{1030}	{1420}	{1840}
JWM (Machine Screw Type) L Speed	N	63	120	220	420	820	1430	1950	2800	4400	6650	9390	13200
	{ kgf }	{6}	{13}	{23}	{44}	{85}	{146}	{200}	{286}	{449}	{678}	{958}	{1350}
JWB (Ball Screw Type) H Speed	N	—	130	220	480	870	1290	2030	2490	3450	5240	7200	9790
	{ kgf }	—	{14}	{23}	{50}	{89}	{132}	{208}	{255}	{352}	{535}	{735}	{998}
JWB (Ball Screw Type) L Speed	N	—	82	140	290	500	840	1300	1610	2400	3560	4940	6970
	{ kgf }	—	{8}	{15}	{31}	{52}	{86}	{133}	{165}	{245}	{363}	{504}	{711}
JWH (High Lead Ball Screw Type) H Speed	N	—	—	530	980	1510	2390	3130	3840	—	—	—	—
	{ kgf }	—	—	{54}	{100}	{154}	{244}	{320}	{392}	—	—	—	—

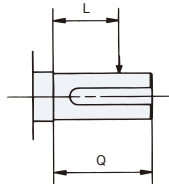

Q : Shaft Length  
 L : Loaded Position

## 2. Screw Shaft rpm

When using a travel nut with screw shaft rotation, make sure the screw shaft rpm is within the rated value determined by the following formula. In cases where it exceeds the allowable rate, increase the frame number and recalculate.

(Verify the allowable screw shaft rpm if the input rpm is 900 r/min or over with H speed standard stroke, or if the stroke used exceeds the standard value.)

$$NC = \frac{96 \times n \times d \times 10^6}{L^2}$$

NC : Allowable screw shaft rpm r/min  
 d : Screw shaft root diameter mm  
 (See pages 169 · 170 for JWM, pages 195 · 196 for JWB and pages 219 · 220 for JWH.)  
 n : Shaft end support coefficient  
 ① Shaft end free: n=0.36  
 ② Fixed shaft end: n=1.56  
 L : Support space distance mm (See graph for each frame no.)

$$NS = \frac{N}{R}$$

NS : Screw shaft rpm r/min  
 N : Input rpm r/min  
 R : Worm speed ratio

### MAKE SURE NC > NS

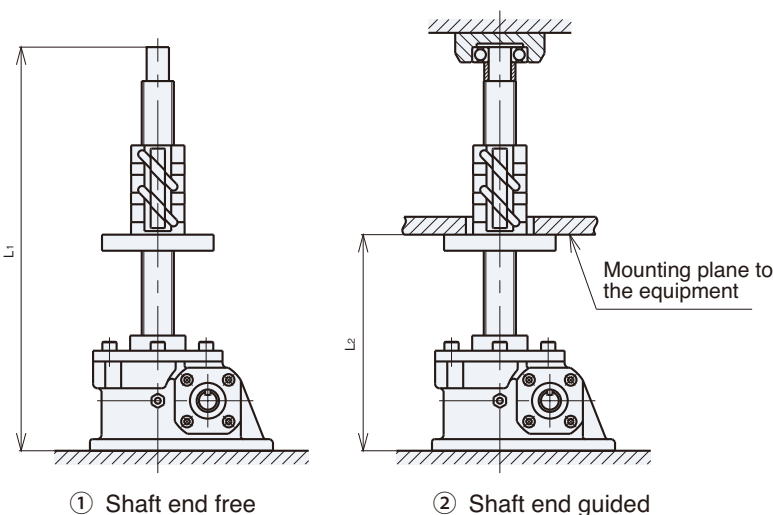

(Calculation Example)

Assume JWM200URH20D with input rpm of 1200r/min with fixed shaft end.

Screw shaft rpm N<sub>s</sub> is:

$$NS = \frac{1200}{8} = 150r/min$$

\* See dimensions on page 186

$$NC = \frac{96 \times 1.56 \times 51.3 \times 10^6}{2237^2}$$

$$= 1535r/min$$

$$NC = 1535r/min > NS = 150r/min \dots OK$$

Linipower Jack

# JWM (Machine Screw Type)

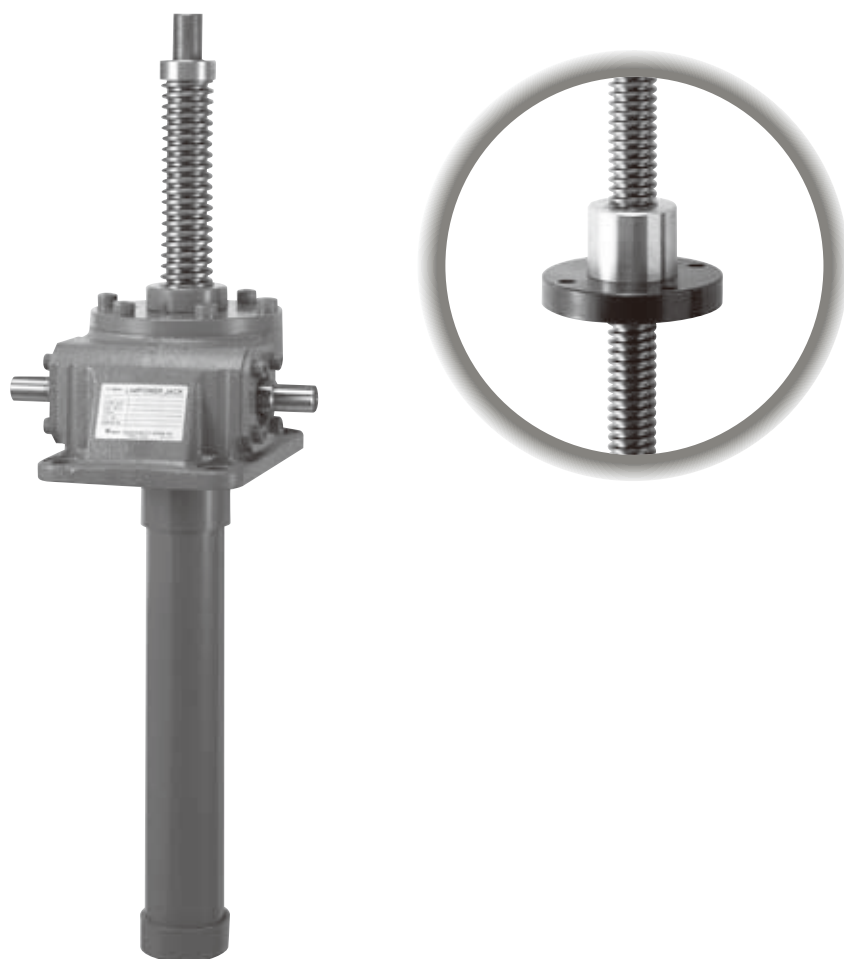

Drawings	—————	P165•166
JWM Reference Number System	—————	P167•168
Reference Table for Standard Use	—————	P169•170
Dimensions	—————	P171~188
Precautions	—————	P189

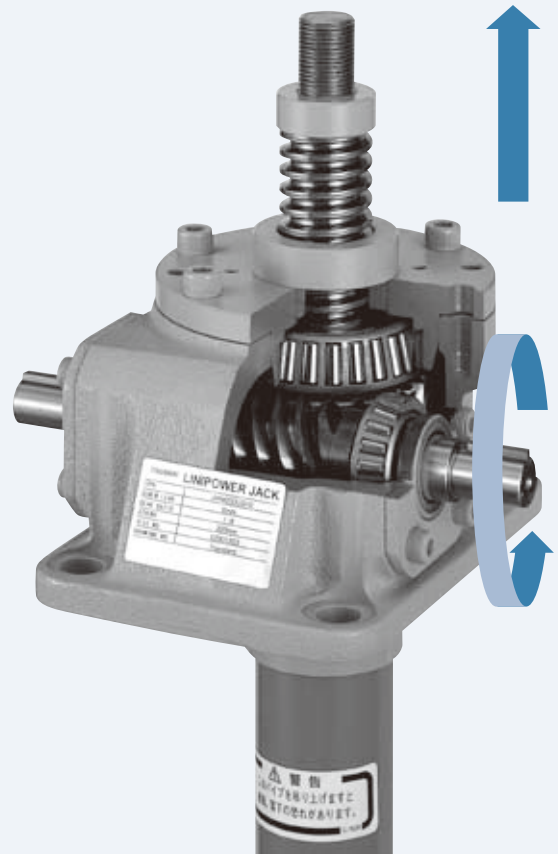
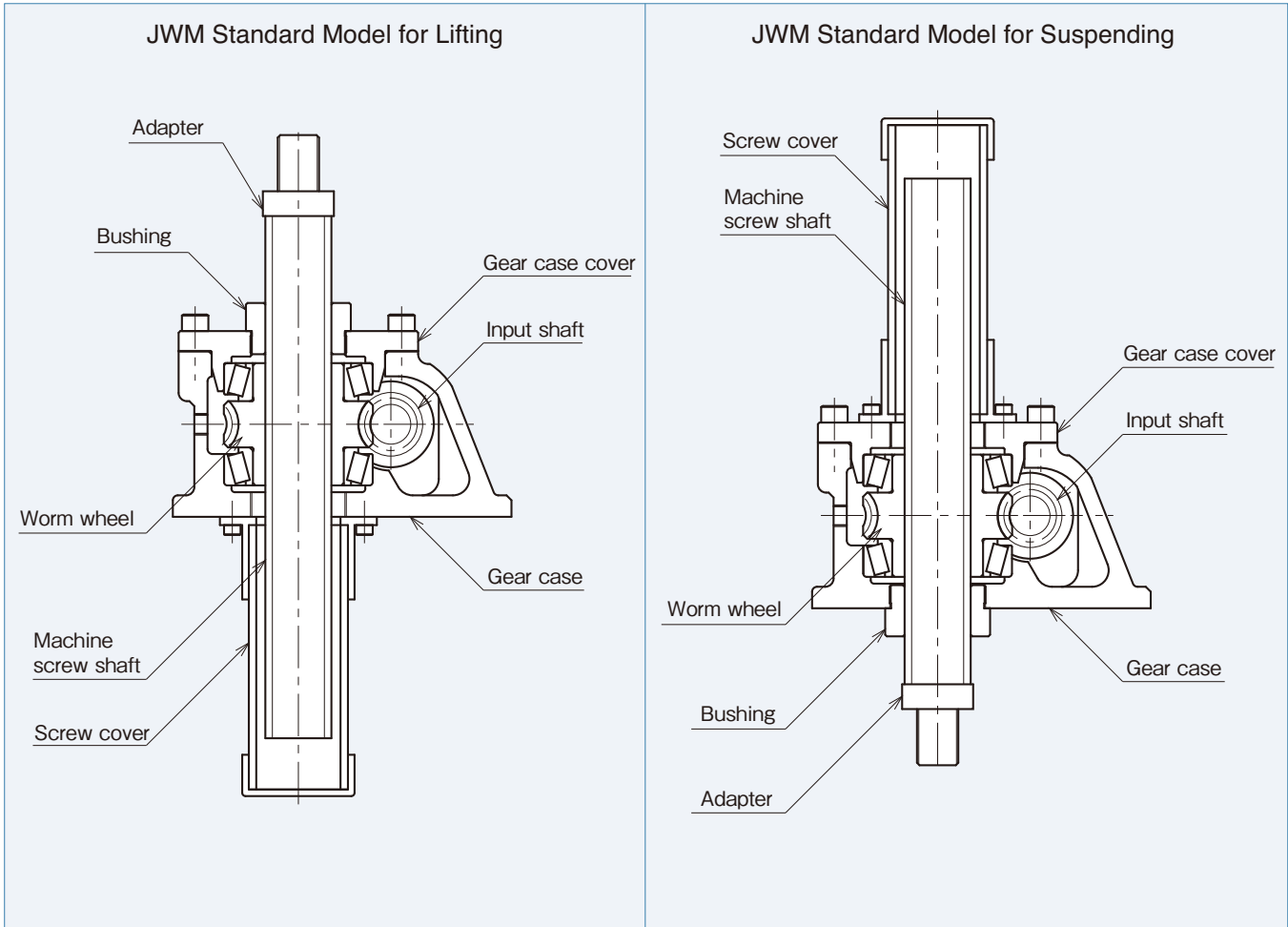

JWM (Machine Screw Type) Rotation Prevention Type

**JWM002~050**

〈Rotation Prevention Type with Guide Nut〉

Screw

Screw cover

Guide nut

Cross section A-A

“square” pipe

Note) The 10° space in each corner between the guide and the pipe allows smooth rotation.

**JWM100•150•200**

〈Rotation Prevention Type with Guide Key〉

Guide key

Cross section A-A

JWM (Machine Screw Type) Travel Nut Type

Screw Shaft

Travel Nut



# JWM (Machine Screw Type)



Linipower Jack

Jack Type  
M : Machine screw

### Basic Capacity

Frame No.	kN	{tf}
002	1.96	{0.2}
005	4.90	{0.5}
010	9.80	{1}
025	24.5	{2.5}
050	49.0	{5}
100	98.0	{10}
150	147	{15}
200	196	{20}
300	294	{30}
500	490	{50}
750	735	{75}
1000	980	{100}

\*Compact type is available for JWM300 and 500. See page 257.

\*JWM750 and 1000 are manufactured upon inspecting specific needs.

### Installation Type

US	Standard Use - Lifting 
DS	Standard Use - Suspending 
UM	Screw shaft anti-rotation specification for lifting  (See page 166.)
DM	Screw shaft anti-rotation specification for Suspending  (See page 166.)

### Stroke mm

1	100
3	300
6	600
10	1000

\*The above values are examples. For actual stroke used, refer to the Model comparison Table for JWM on page 145.

### Gear Ratio

Symbol Frame No.	H	L
002	5	20
005	5	20
010	5	20
025	6	24
050	6	24
100	8	24
150	8	24
200	8	24
300	10 <sup>2/3</sup>	32
500	10 <sup>2/3</sup>	32
750	10 <sup>2/3</sup>	32
1000	12	36

### Flange Installation

U	
D	

\*Be sure to use the flange installation method U or D with travel nuts.

\*Above are only necessary with travel nuts.

Examples)





**JWM100UMH3**

- Machine Screw Type • 98.0kN {10tf} • Rotation prevention (for lifting) • Gear ratio H (1/8) • Stroke 300mm

**JWM050USH10JMK4PG2**

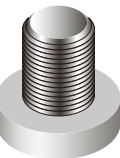
- Machine Screw Type • 49.0kN {5tf} • Standard use (for lifting) • Gear ratio H (1/6) • Stroke 1000mm
- Bellows / Table Type End Fitting • 4 Internal LS • Potentiometer
- 3 Phase motor with brake and gear; reducer ratio of 1/10

Output Option

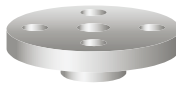

No symbol	Screw Shaft End (standard) 
J	Bellows 
B	Rod Type End Fitting 
I	I Type End Fitting 
M	Table Type End Fitting 

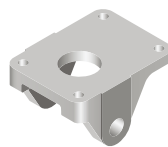
Installation Option

C	Clevis Mounting Adapter  (See page 245)
---	---



Note) For standard lifting only.

Sensor Option

Y	LS Counter    (See page 239)
K2	Position Sensor K2...2 Internal LS K4...4 Internal LS P...Potentiometer R...Rotary Encoder
K4	
P	
R	

Note) To request the above parts, provide their letter symbols in the order given.

Input Option

E	3 phase brake and motor E...200V 50Hz 200/220V 60Hz EV...400 50Hz 400/440V 60Hz  (See page 229~)
G1	3 phase brake and gear-motor G1...Gear ratio 1/5 200V 50Hz 200/220V 60Hz G2...Reducer ratio 1/10 200V 50Hz 200/220V 60Hz  (See page 229~)
G2	

Accessories

<b>Hand Wheel</b>  (See page 246)
<b>Control Options</b> Stroke Meter and PCB  Meter Relay and PCB  (See page 242~)
<b>Others</b> Trunnion Mounting Adapter  * Use as a set with clevis mounting adapter. (See page 245)

Note) To request the above parts, provide their letter symbols in the order given. When travel nuts are used, B, I and M are not required.

Note) Travel nut type with bellows is estimated for each order. Enter necessary information in the inquiry form on page 249 to contact TSUBAKI E&M.

## Reference Table for Standard Use JWM (Machine Screw Type)

Frame No.		JWM002	JWM005	JWM010	JWM025	JWM050
Basic Capacity	kN	1.96	4.90	9.80	24.5	49.0
	{tf}	{0.2}	{0.5}	{1}	{2.5}	{5}
Outer Screw Diameter	mm	12	16	20	26	40
Minor Screw Diameter	mm	8.8	10.8	14.8	19.7	30.5
Screw Lead	mm	3	4	4	5	8
Gear Ratio	H Speed	5	5	5	6	6
	L Speed	20	20	20	24	24
Overall Efficiency	%					
	H Speed	26	26	21	21	22
Max. Allowable Input Capacity	kW					
	L Speed	0.16	0.39	0.49	1.0	2.0
Tare Drag Torque	N · m	0.11	0.11	0.29	0.62	1.4
	{kgf · m}	{0.011}	{0.011}	{0.03}	{0.063}	{0.14}
Allowable Input Torque *Note 1	N · m	9.8	9.8	19.6	49.0	153.9
	{kgf · m}	{1}	{1}	{2}	{5}	{15.7}
Required Input Torque *Note 2 for Basic Capacity	N · m					
	{kgf · m}					
H Speed		0.83	2.5	6.2	16.1	48.7
	{0.08}	{0.26}	{0.64}	{1.6}	{5.0}	
L Speed		0.42	1.1	2.9	7.4	20.0
	{0.04}	{0.12}	{0.30}	{0.75}	{2.0}	
Screw Movement/ per Revolution of Input Shaft	mm					
	H Speed	0.6	0.8	0.8	0.83	1.33
L Speed		0.15	0.2	0.2	0.21	0.33
Max. Input rpm	r/min					
	H Speed	1800	1800	1800	1800	1800
L Speed		1800	1800	1800	1800	1800
Max. Input rpm for Basic Capacity	r/min					
	H Speed	1800	1500	750	600	400
L Speed		1800	1500	1200	600	300
Screw Shaft Rotational Torque for Basic Capacity	N · m	2.6	8.6	20.1	65.1	201.5
	{kgf · m}	{0.26}	{0.87}	{2.1}	{6.6}	{20.5}
Screw Cover Material *Note 3		Hard Vinyl Chloride				
Lubrication		Shaft: Grease Reducer Unit: Grease Bath				
Color		Tsubaki Olive Grey (Munsell 5GY6/0.5)				
Environment	Operating Temperature Range		- 15 to 80°C (Precautions #2)			
	Relative Humidity		85% or less (no dew condensation)			
	Operating ambient atmosphere		Indoor Environment (Indoor room where rain and water cannot enter. Dust volume should be normal.)			
Duty Cycle *Note 4		Within 20% ED				

Note 1) The allowable torque is for jack input shaft only. (Reconfirm if synchronous drive.)

Note 2) Includes tare drag torque.

Note 3) Rotation prevention types for frames 002~050 are steel square pipes.

Note 4) Standard percentage duty cycle is 30 minutes. Thus, driving time is based on 30 minute intervals.

### Precautions

1. All loads (static, dynamic or shock) should be within the rated capacity of the jack at sufficient safety levels.
2. Operating Temperature Range refers to the surface temperature of the jack during operation. To check, measure the surface temperature of the input shaft unit or travel nut (if used). Be sure all the rotating parts have completely stopped before proceeding to measure.
3. Be sure to operate within the allowable input rpm of 1800/min.
4. Number of synchronizing jacks which can be connected on the same line is limited by shaft strength. Refer to the allowable input shaft torque on the above table.
5. Activating torque for the drive unit should be maintained at 200% above the required torque.
6. If operating in freezing temperatures, a change in viscosity may reduce the efficiency of the grease. Set the drive unit so as to accommodate this change.

JWM100	JWM150	JWM200	JWM300	JWM500	JWM750	JWM1000
98.0	147	196	294	490	735	980
{10}	{15}	{20}	{30}	{50}	{75}	{100}
50	55	65	85	120	130	150
38.4	43.4	51.3	67	102	112	127
10	10	12	16	16	16	20
8	8	8	10 2/3	10 2/3	10 2/3	12
24	24	24	32	32	32	36
22	20	20	19	15	13	13
15	14	13	11	10	8	8
2.8	3.1	5.0	8.4	13.4	14.4	21.4
1.4	2.2	3.2	4.6	5.7	7.2	9.4
2.0	2.6	3.9	9.8	19.6	29.4	39.2
{0.2}	{0.27}	{0.4}	{1}	{2}	{3}	{4}
292	292.0	292.0	735.0	1372.0	1764.0	2450.0
{29.8}	{29.8}	{29.8}	{75}	{140}	{180}	{250}
90.7	149	238.1	400.1	856.0	1380.5	2040.9
{9.2}	{15.2}	{24.3}	{40.8}	{87.3}	{140.7}	{208.0}
45.3	72.3	124.0	244.0	453.3	761.3	1278.3
{4.6}	{7.4}	{12.6}	{24.9}	{46.2}	{77.6}	{130.3}
1.25	1.25	1.50	1.50	1.50	1.50	1.67
0.42	0.42	0.50	0.50	0.50	0.50	0.56
1800	1800	1800	1800	1800	1800	1800
1800	1800	1800	1800	1800	1800	1800
300	200	200	200	150	100	100
300	290	250	180	120	90	70
503.6	813.2	1287.7	2531.9	5551.3	8921.8	13878.3
{51.3}	{82.9}	{131.3}	{258.1}	{565.9}	{909.5}	{1414.7}
<b>Steel Pipe</b>						
<b>Screw: Grease Reducer Unit: Grease Bath</b>						
<b>Tsubaki Olive Grey (Munsell 5GY6/0.5)</b>						
<b>- 15 to 80°C (Precautions #2)</b>						
<b>85% or less (no dew condensation)</b>						
<b>Indoor Environment (Indoor room where rain and water cannot enter. Dust volume should be normal.)</b>						
<b>Within 20% ED</b>						

7. Although JWM (Machine Screw Type) comes with a self-locking device, it may not be effective with vibration or shock. Use a brake under such conditions.
- ⚠8. Be certain that the jack rating exceeds the maximum stroke. Over travel can cause the lift shaft to disengage from the worm wheel. JWM (Machine screw type) is not equipped with a fall stop, therefore, if the stroke range is exceeded, the screw shaft falls.
- ⚠9. Do not use mechanical stops under any circumstances. This will cause major internal damage.
10. Input shaft key is provided with each unit. (The input shaft key complies with JIS B 1301-1996 (normal grade).)

## JWM002 Dimensions - Standard Model

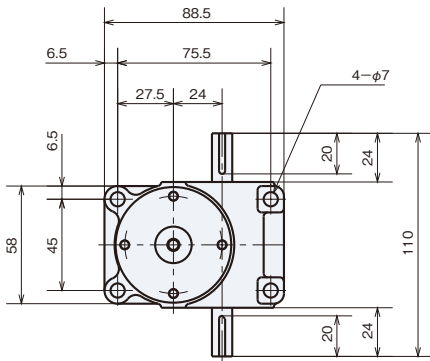

Stroke	US Standard Model for Lifting					DS Standard Model for Suspending					Weight kg
	X		X		L	X		X		L	
	Without Bellows	With Bellows	Without Bellows	With Bellows		Without Bellows	With Bellows	Without Bellows	With Bellows		
100	73	173	127	227	184	20	120	65	165	184	2.3
200	73	273	127	327	284	20	220	65	265	284	2.4
300	73	373	167	467	424	20	320	105	405	424	2.6
400	73	473	167	567	524	20	420	105	505	524	2.7

Lift (JWM002US)

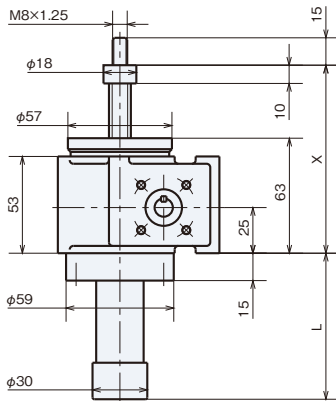

Suspend (JWM002DS)

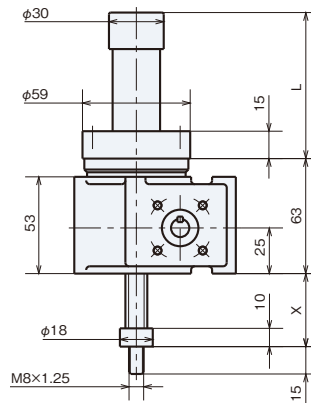

● Input Shaft

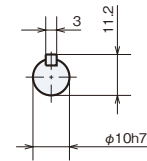

## JWM002 Dimensions - Rotation Prevention Type

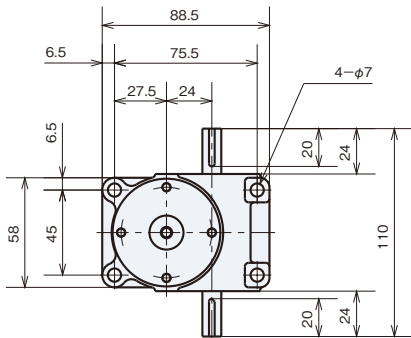

Stroke	UM Rotation Prevention Type for Lifting					DM Rotation Prevention Type for Suspending					Weight kg
	X		X		L	X		X		L	
	Without Bellows	With Bellows	Without Bellows	With Bellows		Without Bellows	With Bellows	Without Bellows	With Bellows		
100	73	173	127	227	202	20	120	65	165	202	3.0
200	73	273	127	327	302	20	220	65	265	302	3.4
300	73	373	167	467	442	20	320	105	405	442	3.9
400	73	473	167	567	542	20	420	105	505	542	4.3

Lift (JWM002UM)

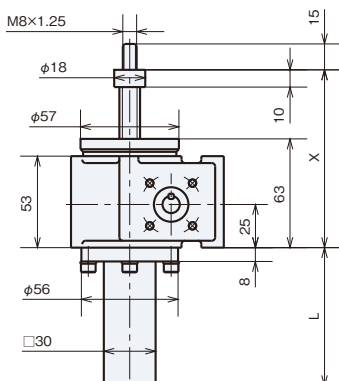

Suspend (JWM002DM)

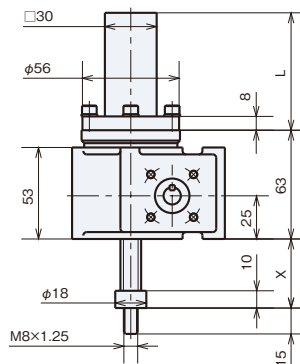

● Input Shaft

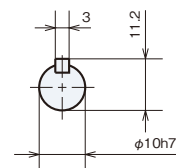

# Output Options

■ Bellows ( - J)

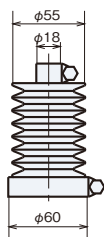

■ Rod Type End Fitting ( - B)

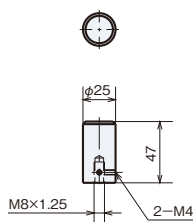

■ I Type End Fitting ( - I)

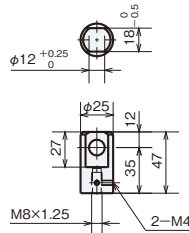

■ Table Type End Fitting ( - M)

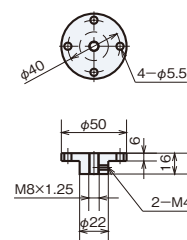

Note) For detailed measurements on units with bellows, see page 248.

# JWM002 Dimensions - Travel Nut Type

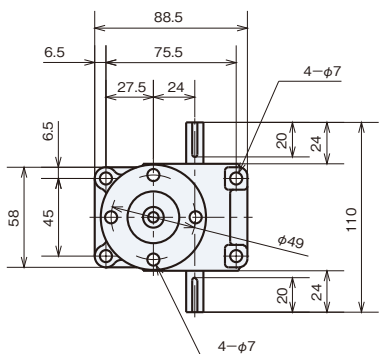

Stroke	UR Travel Nut Type for Lifting			DR Travel Nut Type for Suspending			Weight kg
	X		Y	X		Y	
	MIN	MAX		MIN	MAX		
100	84	184	207	35	135	145	2.6
200	84	284	307	35	235	245	2.6
300	84	384	407	35	335	345	2.7
400	84	484	507	35	435	445	2.8

Lift (JWM002UR)

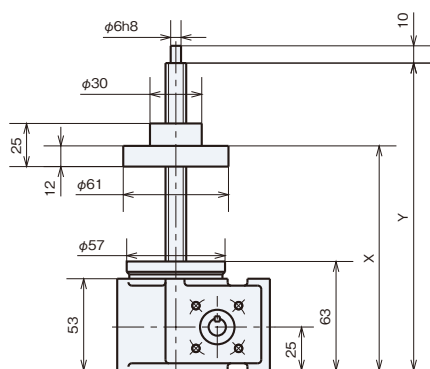

Suspend (JWM002DR)

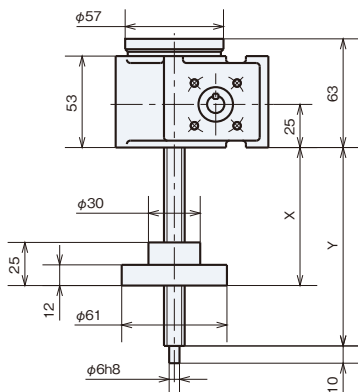

● Input Shaft

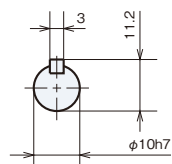

Travel nut type cannot be equipped with optional end fitting (B.I.M).  
For types with bellows, refer to page 249.

\* For dimensions with no tolerances, general tolerances shall apply, and they may be approximately 2 – 5mm larger than the dimensions shown. For machine design, take margins into consideration.

## JWM005 Dimensions - Standard Model

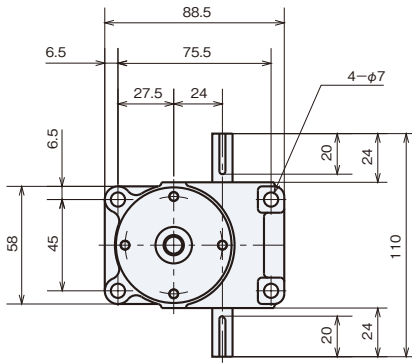

Stroke	US Standard Model for Lifting					DS Standard Model for Suspending					Weight kg
	X		X		L	X		X		L	
	Without Bellows	With Bellows	Without Bellows	With Bellows		Without Bellows	With Bellows	Without Bellows	With Bellows		
MIN	MAX	MIN	MAX		MIN	MAX	MIN	MAX			
100	73	173	127	227	188	20	120	65	165	188	2.5
200	73	273	127	327	288	20	220	65	265	288	2.6
300	73	373	167	467	428	20	320	105	405	428	2.8
400	73	473	167	567	528	20	420	105	505	528	3.0
500	73	573	202	702	663	20	520	140	640	663	3.2
600	73	673	202	802	763	20	620	140	740	763	3.3
800	73	873	237	1037	998	20	820	175	975	998	3.7

Lift (JWM005US)

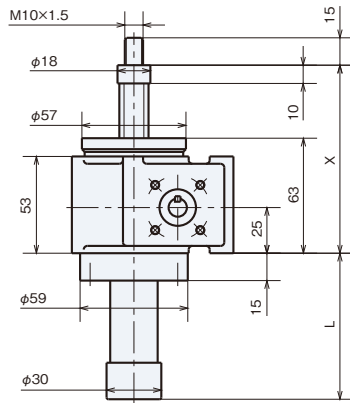

Suspend (JWM005DS)

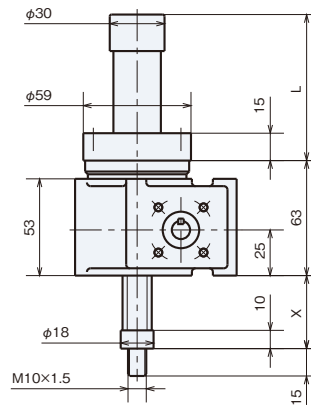

● Input Shaft

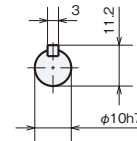

## JWM005 Dimensions - Rotation Prevention Type

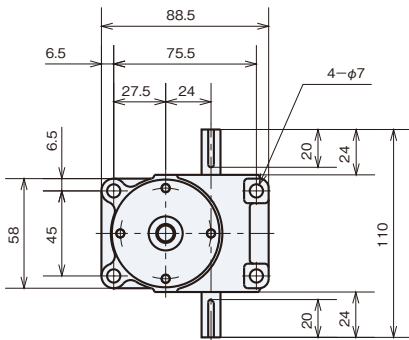

Stroke	UM Rotation Prevention Type for Lifting					DM Rotation Prevention Type for Suspending					Weight kg
	X		X		L	X		X		L	
	Without Bellows	With Bellows	Without Bellows	With Bellows		Without Bellows	With Bellows	Without Bellows	With Bellows		
MIN	MAX	MIN	MAX		MIN	MAX	MIN	MAX			
100	73	173	127	227	202	20	120	65	165	202	3.1
200	73	273	127	327	302	20	220	65	265	302	3.5
300	73	373	167	467	442	20	320	105	405	442	4.1
400	73	473	167	567	542	20	420	105	505	542	4.6
500	73	573	202	702	677	20	520	140	640	677	5.1
600	73	673	202	802	777	20	620	140	740	777	5.5
800	73	873	237	1037	1012	20	820	175	975	1012	6.5

Lift (JWM005UM)

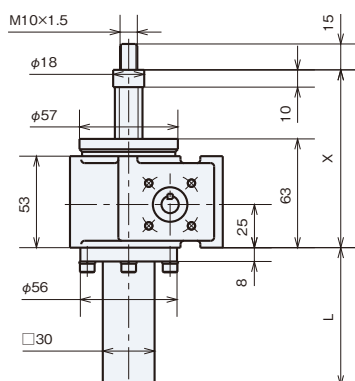

Suspend (JWM005DM)

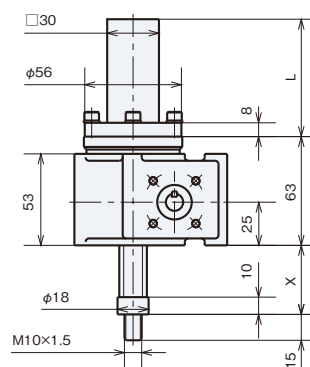

● Input Shaft

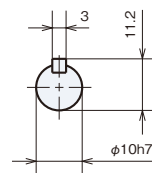



## Output Options

■ Bellows ( - J)

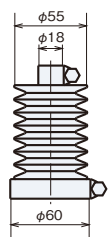

■ Rod Type End Fitting ( - B)

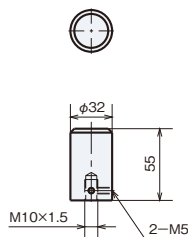

■ I Type End Fitting ( - I)

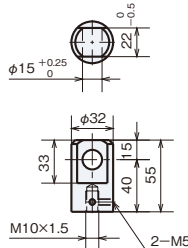

■ Table Type End Fitting ( - M)

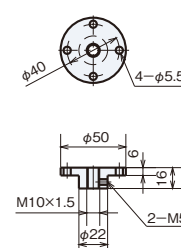

Note) For detailed measurements on units with bellows, see page 248.

## JWM005 Dimensions - Travel Nut Type

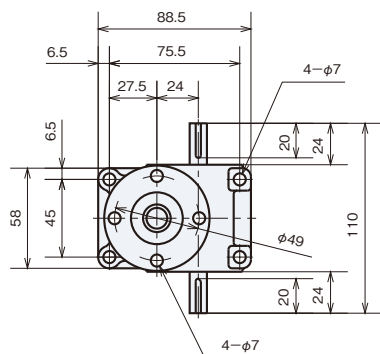

Stroke	UR Travel Nut Type for Lifting			DR Travel Nut Type for Suspending			Weight kg
	X		Y	X		Y	
	MIN	MAX		MIN	MAX		
100	84	184	207	35	135	145	2.6
200	84	284	307	35	235	245	2.8
300	84	384	407	35	335	345	2.9
400	84	484	507	35	435	445	3.0
500	84	584	607	35	535	545	3.1
600	84	684	707	35	635	645	3.2
800	84	884	907	35	835	845	3.5

**Lift (JWM005UR)**

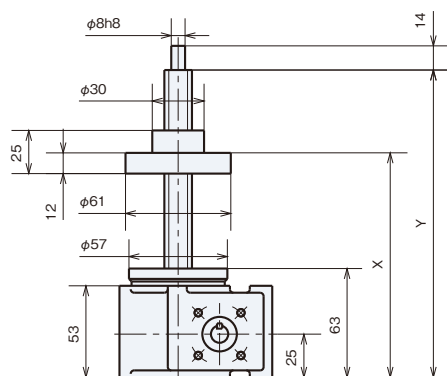

**Suspend (JWM005DR)**

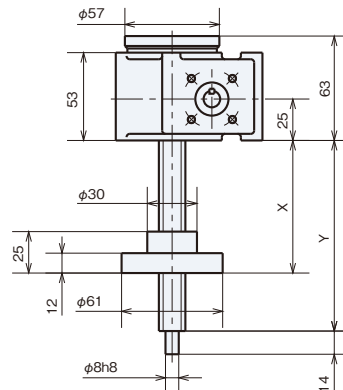

● Input Shaft

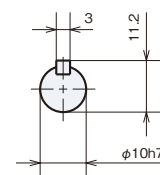

Travel nut type cannot be equipped with optional end fitting (B.I.M).  
For types with bellows, refer to page 249.

## JWM010 Dimensions - Standard Model

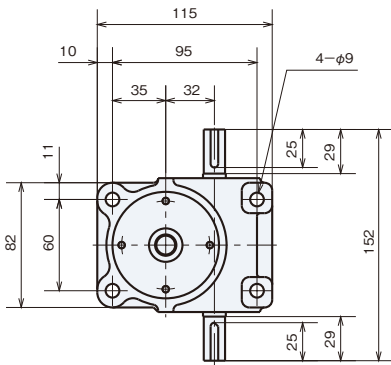

Stroke	US Standard Model for Lifting					DS Standard Model for Suspending					Weight kg
	X		X		L	X		X		L	
	Without Bellows	With Bellows	Without Bellows	With Bellows		Without Bellows	With Bellows	Without Bellows	With Bellows		
MIN	MAX	MIN	MAX		MIN	MAX	MIN	MAX			
100	101	201	161	261	194	25	125	75	175	194	5.5
200	101	301	161	361	294	25	225	75	275	294	5.7
300	101	401	201	501	434	25	325	115	415	434	6.1
400	101	501	201	601	534	25	425	115	515	534	6.3
500	101	601	236	736	669	25	525	150	650	669	6.6
600	101	701	236	836	769	25	625	150	750	769	6.9
800	101	901	271	1071	1004	25	825	185	985	1004	7.5
1000	101	1101	301	1301	1234	25	1025	215	1215	1234	8.0

Lift (JWM010US)

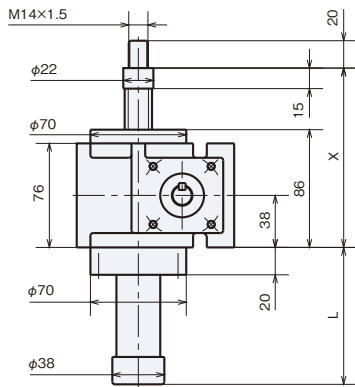

Suspend (JWM010DS)

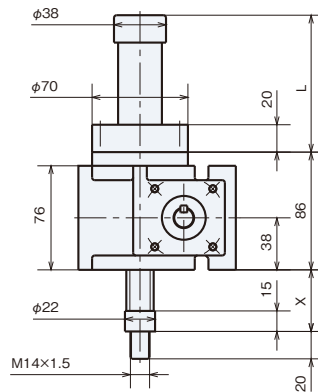

● Input Shaft

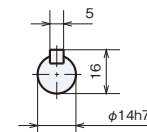

## JWM010 Dimensions - Rotation Prevention Type

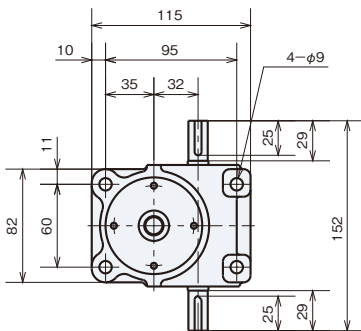

Stroke	UM Rotation Prevention Type for Lifting					DM Rotation Prevention Type for Suspending					Weight kg
	X		X		L	X		X		L	
	Without Bellows	With Bellows	Without Bellows	With Bellows		Without Bellows	With Bellows	Without Bellows	With Bellows		
MIN	MAX	MIN	MAX		MIN	MAX	MIN	MAX			
100	101	201	161	261	213	25	125	75	175	213	6.6
200	101	301	161	361	313	25	225	75	275	313	7.2
300	101	401	201	501	453	25	325	115	415	453	8.1
400	101	501	201	601	553	25	425	115	515	553	8.8
500	101	601	236	736	688	25	525	150	650	688	9.6
600	101	701	236	836	788	25	625	150	750	788	11
800	101	901	271	1071	1023	25	825	185	985	1023	12
1000	101	1101	301	1301	1253	25	1025	215	1215	1253	14

Lift (JWM010UM)

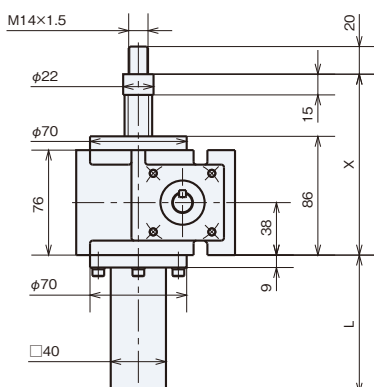

Suspend (JWM010DM)

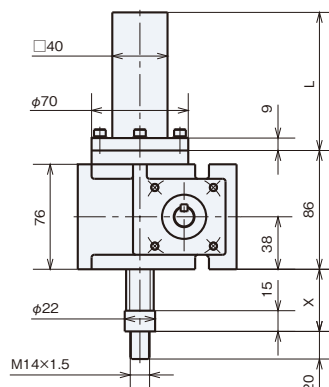

● Input Shaft

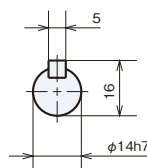

# Output Options

■ Bellows ( - J)

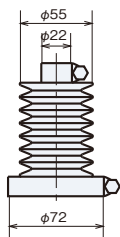

■ Rod Type End Fitting ( - B)

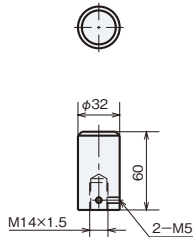

■ I Type End Fitting ( - I)

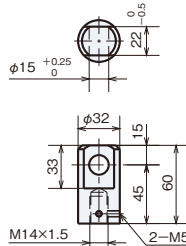

■ Table Type End Fitting ( - M)

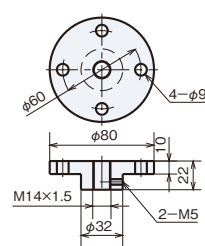

Note) For detailed measurements on units with bellows, see page 248.

# JWM010 Dimensions - Travel Nut Type

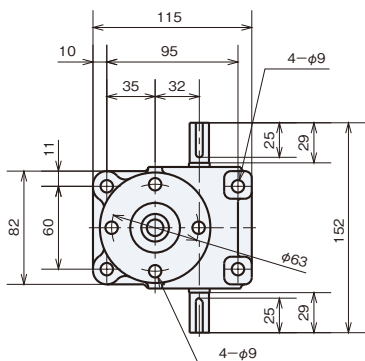

Stroke	UR Travel Nut Type for Lifting			DR Travel Nut Type for Suspending			Weight kg
	X		Y	X		Y	
	MIN	MAX		MIN	MAX		
100	108	208	246	50	150	160	5.9
200	108	308	346	50	250	260	6.1
300	108	408	446	50	350	360	6.2
400	108	508	546	50	450	460	6.4
500	108	608	646	50	550	560	6.6
600	108	708	746	50	650	660	6.8
800	108	908	946	50	850	860	7.2
1000	108	1108	1146	50	1050	1060	7.6

Lift (JWM010UR)

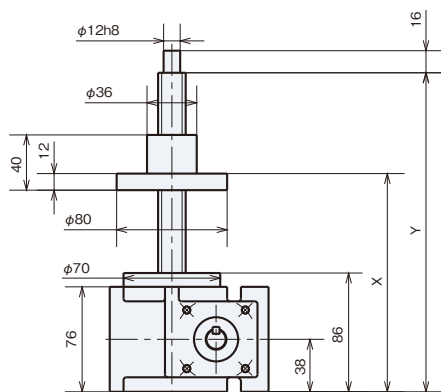

Suspend (JWM010DR)

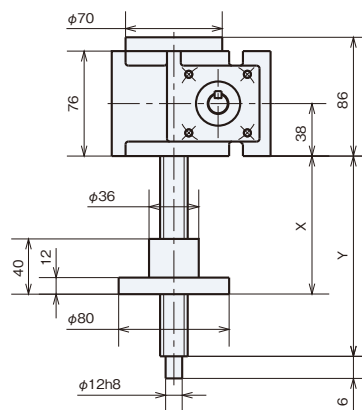

● Input Shaft

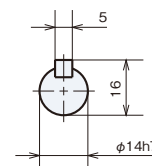

Travel nut type cannot be equipped with optional end fitting (B.I.M).  
For types with bellows, refer to page 249.

## JWM025 Dimensions - Standard Model

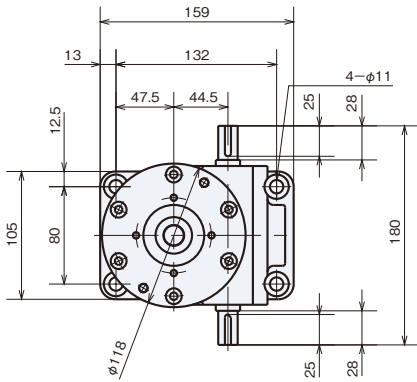

Stroke	US Standard Model for Lifting					DS Standard Model for Suspending					Weight kg
	X		X		L	X		X		L	
	Without Bellows	With Bellows	Without Bellows	With Bellows		Without Bellows	With Bellows	Without Bellows	With Bellows		
MIN	MAX	MIN	MAX		MIN	MAX	MIN	MAX			
100	132	232	147	247	149	42	142	57	157	149	7.7
200	132	332	147	347	249	42	242	57	257	249	8.1
300	132	432	167	467	369	42	342	77	377	369	8.5
400	132	532	167	567	469	42	442	77	477	469	8.9
500	132	632	187	687	589	42	542	97	597	589	9.4
600	132	732	187	787	689	42	642	97	697	689	9.8
800	132	932	207	1007	909	42	842	117	917	909	11
1000	132	1132	227	1227	1129	42	1042	137	1137	1129	12
1200	132	1332	242	1442	1344	42	1242	152	1352	1344	13

Lift (JWM025US)

Suspend (JWM025DS)

● Input Shaft

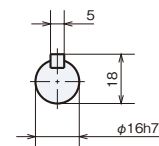
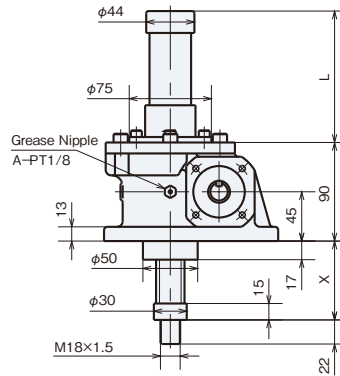
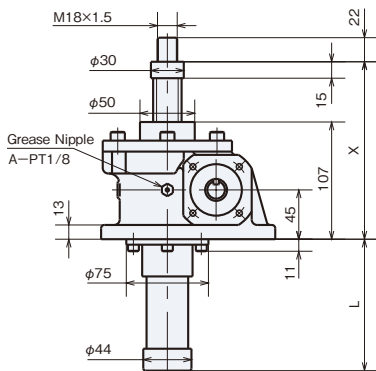

## JWM025 Dimensions - Rotation Prevention Type

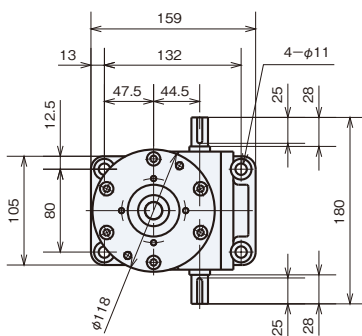

Stroke	UM Rotation Prevention Type for Lifting					DM Rotation Prevention Type for Suspending					Weight kg
	X		X		L	X		X		L	
	Without Bellows	With Bellows	Without Bellows	With Bellows		Without Bellows	With Bellows	Without Bellows	With Bellows		
MIN	MAX	MIN	MAX		MIN	MAX	MIN	MAX			
100	132	232	147	247	181	42	142	57	157	181	10
200	132	332	147	347	281	42	242	57	257	281	12
300	132	432	167	467	401	42	342	77	377	401	13
400	132	532	167	567	501	42	442	77	477	501	14
500	132	632	187	687	621	42	542	97	597	621	15
600	132	732	187	787	721	42	642	97	697	721	17
800	132	932	207	1007	941	42	842	117	917	941	19
1000	132	1132	227	1227	1161	42	1042	137	1137	1161	21
1200	132	1332	242	1442	1376	42	1242	152	1352	1376	24

Lift (JWM025UM)

Suspend (JWM025DM)

● Input Shaft

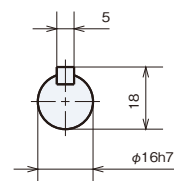
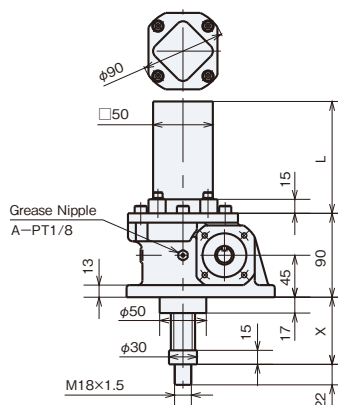
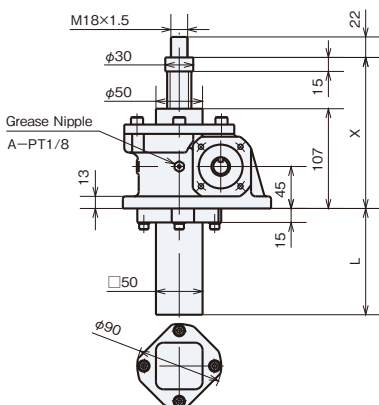

# Output Options

■ Bellows ( - J)

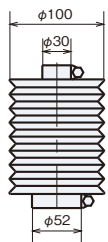

■ Rod Type End Fitting ( - B)

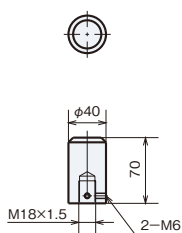

■ I Type End Fitting ( - I)

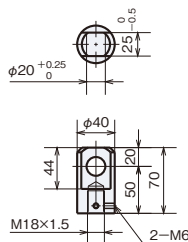

■ Table Type End Fitting ( - M)

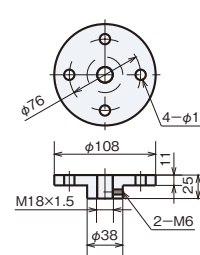

# JWM025 Dimensions - Travel Nut Type

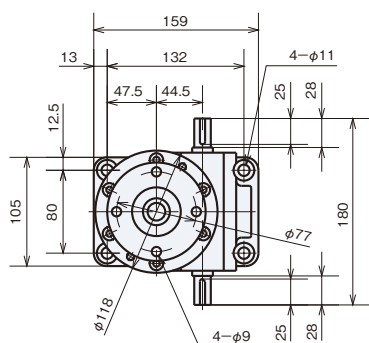

Stroke	UR Travel Nut Type for Lifting			DR Travel Nut Type for Suspending			Weight kg
	X		Y	X		Y	
	MIN	MAX		MIN	MAX		
100	133	233	279	79	179	189	9.2
200	133	333	379	79	279	289	9.5
300	133	433	479	79	379	389	9.9
400	133	533	579	79	479	489	11
500	133	633	679	79	579	589	11
600	133	733	779	79	679	689	11
800	133	933	979	79	879	889	12
1000	133	1133	1179	79	1079	1089	13
1200	133	1333	1379	79	1279	1289	13

Lift (JWM025UR)

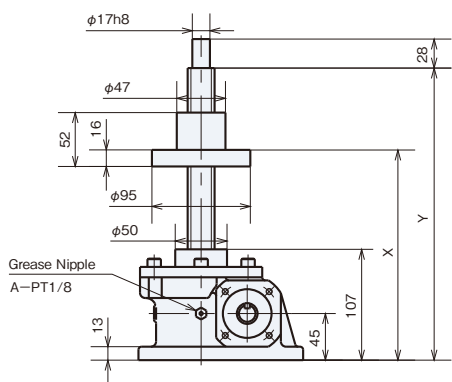

Suspend (JWM025DR)

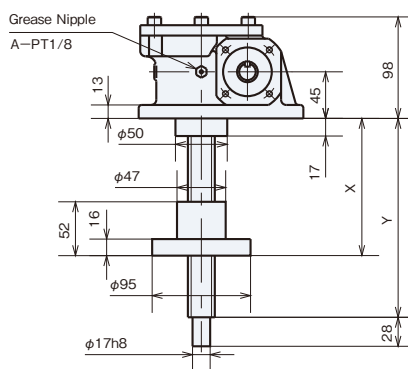

● Input Shaft

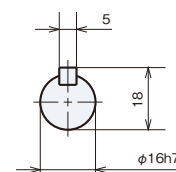

Travel nut type cannot be equipped with optional end fitting (B.I.M).  
For types with bellows, refer to page 249.

\* For dimensions with no tolerances, general tolerances shall apply, and they may be approximately 2 – 5mm larger than the dimensions shown. For machine design, take margins into consideration.

## JWM050 Dimensions - Standard Model

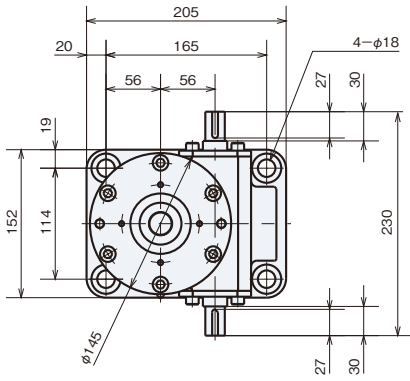

Stroke	US Standard Model for Lifting					DS Standard Model for Suspending					Weight kg
	X		X		L	X		X		L	
	Without Bellows	With Bellows	Without Bellows	With Bellows		Without Bellows	With Bellows	Without Bellows	With Bellows		
MIN	MAX	MIN	MAX		MIN	MAX	MIN	MAX			
100	154	254	169	269	147	42	142	57	157	147	18
200	154	354	169	369	247	42	242	57	257	247	19
300	154	454	189	489	367	42	342	77	377	367	20
400	154	554	189	589	467	42	442	77	477	467	21
500	154	654	209	709	587	42	542	97	597	587	22
600	154	754	209	809	687	42	642	97	697	687	23
800	154	954	229	1029	907	42	842	117	917	907	25
1000	154	1154	249	1249	1127	42	1042	137	1137	1127	27
1200	154	1354	264	1464	1342	42	1242	152	1352	1342	29
1500	154	1654	289	1789	1667	42	1542	177	1677	1667	32

Lift (JWM050US)

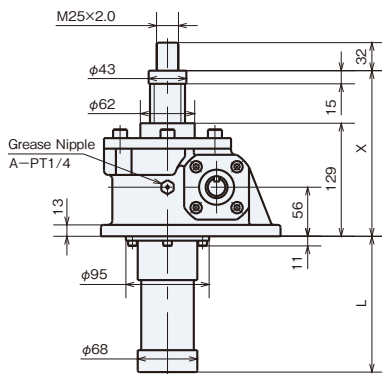

Suspend (JWM050DS)

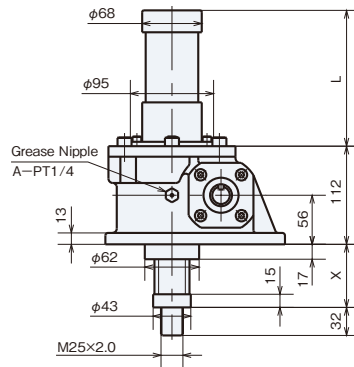

● Input Shaft

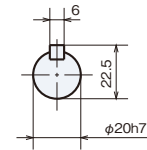

## JWM050 Dimensions - Rotation Prevention Type

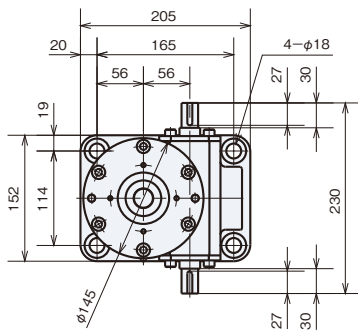

Stroke	UM Rotation Prevention Type for Lifting					DM Rotation Prevention Type for Suspending					Weight kg
	X		X		L	X		X		L	
	Without Bellows	With Bellows	Without Bellows	With Bellows		Without Bellows	With Bellows	Without Bellows	With Bellows		
MIN	MAX	MIN	MAX		MIN	MAX	MIN	MAX			
100	154	254	169	269	196	42	142	57	157	196	22
200	154	354	169	369	296	42	242	57	257	296	24
300	154	454	189	489	416	42	342	77	377	416	26
400	154	554	189	589	516	42	442	77	477	516	28
500	154	654	209	709	636	42	542	97	597	636	30
600	154	754	209	809	736	42	642	97	697	736	32
800	154	954	229	1029	956	42	842	117	917	956	36
1000	154	1154	249	1249	1176	42	1042	137	1137	1176	40
1200	154	1354	264	1464	1391	42	1242	152	1352	1391	44
1500	154	1654	289	1789	1716	42	1542	177	1677	1716	50

Lift (JWM050UM)

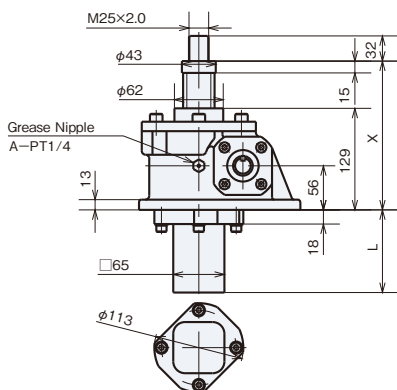

Suspend (JWM050DM)

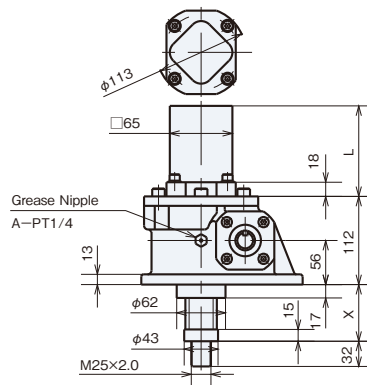

● Input Shaft

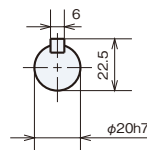

# Output Options

■ Bellows ( - J)



■ Rod Type End Fitting ( - B)

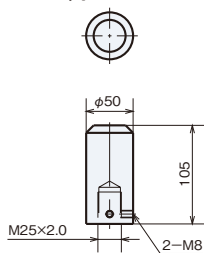

■ I Type End Fitting ( - I)

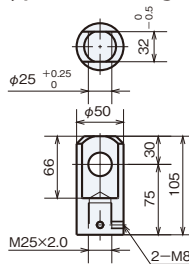

■ Table Type End Fitting ( - M)

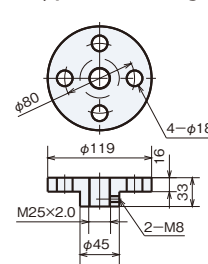

# JWM050 Dimensions - Travel Nut Type

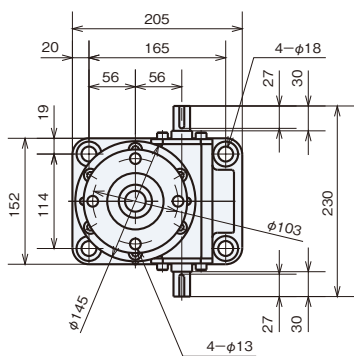

Stroke	UR Travel Nut Type for Lifting			DR Travel Nut Type for Suspending			Weight kg
	X		Y	X		Y	
	MIN	MAX		MIN	MAX		
100	157	257	330	107	207	218	22
200	157	357	430	107	307	318	22
300	157	457	530	107	407	418	23
400	157	557	630	107	507	518	24
500	157	657	730	107	607	618	25
600	157	757	830	107	707	718	26
800	157	957	1030	107	907	918	27
1000	157	1157	1230	107	1107	1118	29
1200	157	1357	1430	107	1307	1318	30
1500	157	1657	1730	107	1607	1618	33

Lift (JWM050UR)

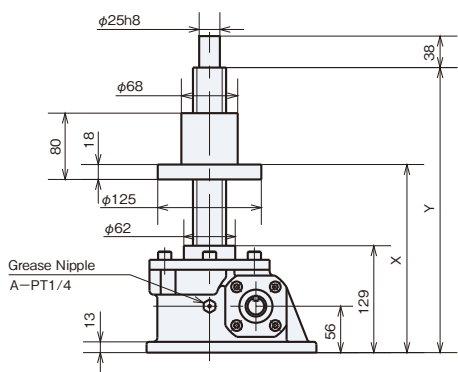

Suspend (JWM050DR)

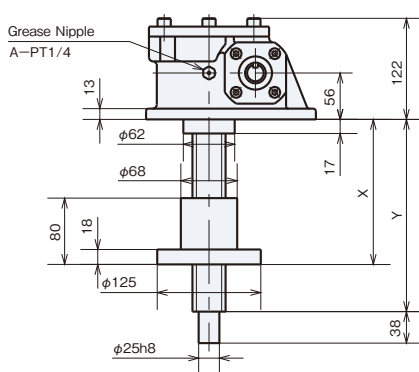

● Input Shaft

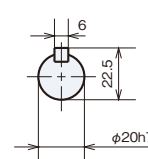

Travel nut type cannot be equipped with optional end fitting (B.I.M).  
For types with bellows, refer to page 249.

\* For dimensions with no tolerances, general tolerances shall apply, and they may be approximately 2 – 5mm larger than the dimensions shown. For machine design, take margins into consideration.



## JWM100 Dimensions - Standard Model

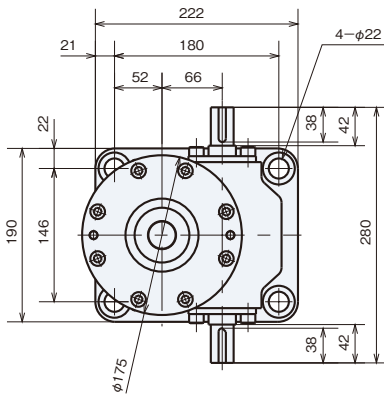

Stroke	US Standard Model for Lifting					DS Standard Model for Suspending					Weight kg
	X		X		L	X		X		L	
	Without Bellows	With Bellows	Without Bellows	With Bellows		Without Bellows	With Bellows	Without Bellows	With Bellows		
MIN	MAX	MIN	MAX	MIN	MAX	MIN	MAX	MIN	MAX		
100	161	261	171	271	151	42	142	52	152	151	27
200	161	361	171	371	252	42	242	52	252	252	29
300	161	461	186	486	366	42	342	67	367	366	32
400	161	561	186	586	466	42	442	67	467	466	34
500	161	661	211	711	591	42	542	92	592	591	37
600	161	761	211	811	691	42	642	92	692	691	40
800	161	961	226	1026	906	42	842	107	907	906	45
1000	161	1161	236	1236	1116	42	1042	117	1117	1116	50
1200	161	1361	261	1461	1341	42	1242	142	1342	1341	56
1500	161	1661	286	1786	1666	42	1542	167	1667	1666	63

Lift (JWM100US)

Suspend (JWM100DS)

● Input Shaft

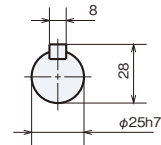
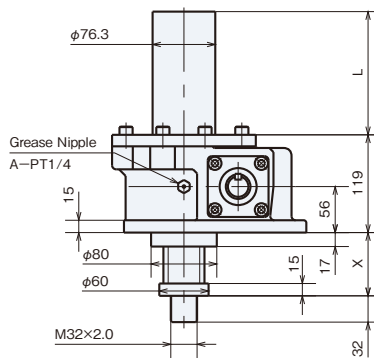
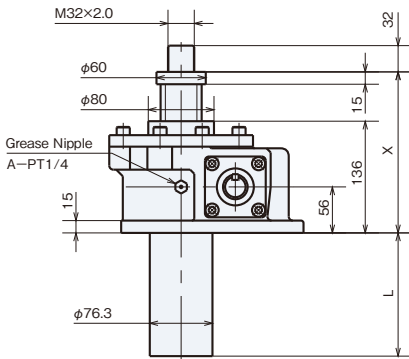

## JWM100 Dimensions - Rotation Prevention Type

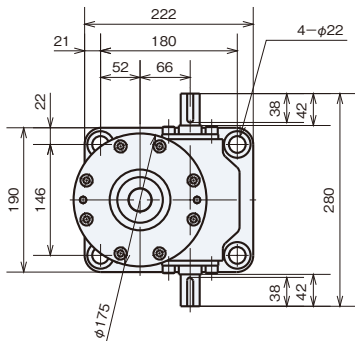

Stroke	UM Rotation Prevention Type for Lifting					DM Rotation Prevention Type for Suspending					Weight kg
	X		X		L	X		X		L	
	Without Bellows	With Bellows	Without Bellows	With Bellows		Without Bellows	With Bellows	Without Bellows	With Bellows		
MIN	MAX	MIN	MAX	MIN	MAX	MIN	MAX	MIN	MAX		
100	194	294	204	304	151	42	142	52	152	151	30
200	194	394	204	404	252	42	242	52	252	252	32
300	194	494	219	519	366	42	342	67	367	366	35
400	194	594	219	619	466	42	442	67	467	466	37
500	194	694	244	744	591	42	542	92	592	591	40
600	194	794	244	844	691	42	642	92	692	691	43
800	194	994	259	1059	906	42	842	107	907	906	48
1000	194	1194	269	1269	1116	42	1042	117	1117	1116	53
1200	194	1394	294	1494	1341	42	1242	142	1342	1341	58
1500	194	1694	319	1819	1666	42	1542	167	1667	1666	66

Lift (JWM100UM)

Suspend (JWM100DM)

● Input Shaft

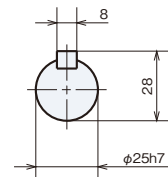
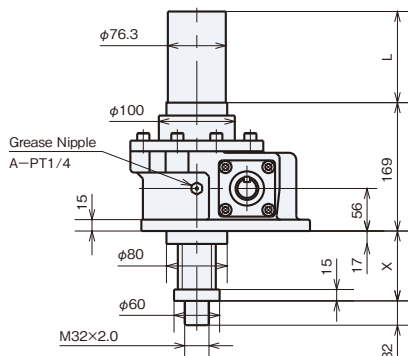
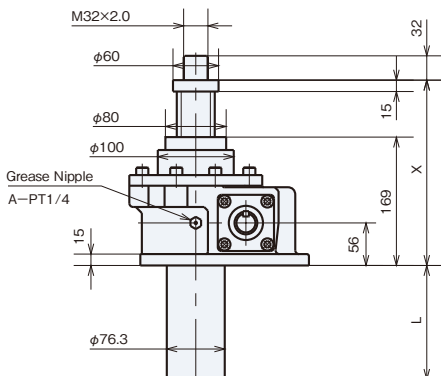

# Output Options

■ Bellows ( - J)

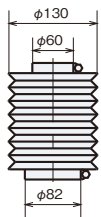

■ Rod Type End Fitting ( - B)

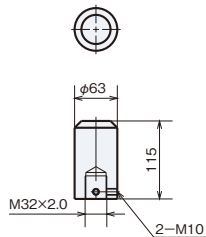

■ I Type End Fitting ( - I)

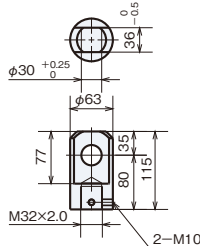

■ Table Type End Fitting ( - M)

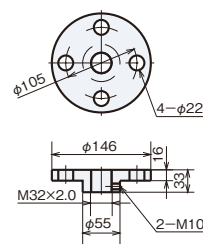

# JWM100 Dimensions - Travel Nut Type

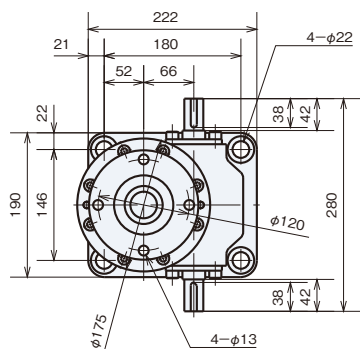

Stroke	UR Travel Nut Type for Lifting			DR Travel Nut Type for Suspending			Weight kg
	X		Y	X		Y	
	MIN	MAX		MIN	MAX		
100	184	284	344	115	215	225	32
200	184	384	444	115	315	325	33
300	184	484	544	115	415	425	34
400	184	584	644	115	515	525	36
500	184	684	744	115	615	625	37
600	184	784	844	115	715	725	38
800	184	984	1044	115	915	925	41
1000	184	1184	1244	115	1115	1125	43
1200	184	1384	1444	115	1315	1325	45
1500	184	1684	1744	115	1615	1625	49

Lift (JWM100UR)

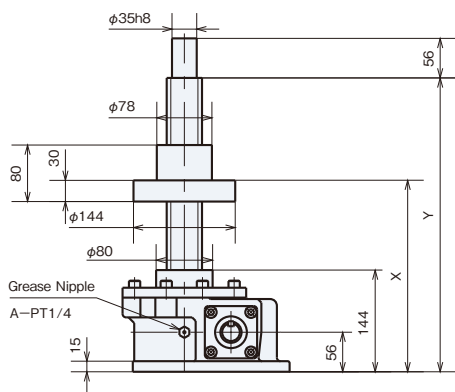

Suspend (JWM100DR)

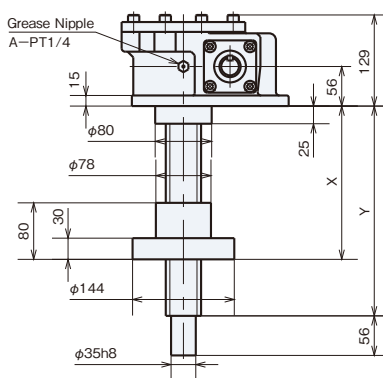

● Input Shaft

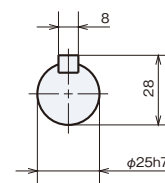

Travel nut type cannot be equipped with optional end fitting (B.I.M).  
For types with bellows, refer to page 249.

\* For dimensions with no tolerances, general tolerances shall apply, and they may be approximately 2 – 5mm larger than the dimensions shown. For machine design, take margins into consideration.

## JWM150 Dimensions - Standard Model

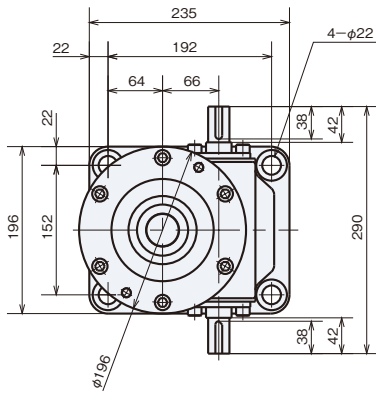

Stroke	US Standard Model for Lifting					DS Standard Model for Suspending					Weight kg
	X		X		L	X		X		L	
	Without Bellows	With Bellows	Without Bellows	With Bellows		Without Bellows	With Bellows	Without Bellows	With Bellows		
MIN	MAX	MIN	MAX	MIN	MAX	MIN	MAX	MIN	MAX		
100	183	283	193	293	151	42	142	52	152	151	33
200	183	383	193	393	252	42	242	52	252	252	35
300	183	483	208	508	366	42	342	67	367	366	38
400	183	583	208	608	466	42	442	67	467	466	41
500	183	683	233	733	591	42	542	92	592	591	45
600	183	783	233	833	691	42	642	92	692	691	47
800	183	983	248	1048	906	42	842	107	907	906	53
1000	183	1183	258	1258	1116	42	1042	117	1117	1116	59
1200	183	1383	283	1483	1341	42	1242	142	1342	1341	65
1500	183	1683	308	1808	1666	42	1542	167	1667	1666	74

Lift (JWM150US)

Suspend (JWM150DS)

● Input Shaft

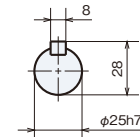
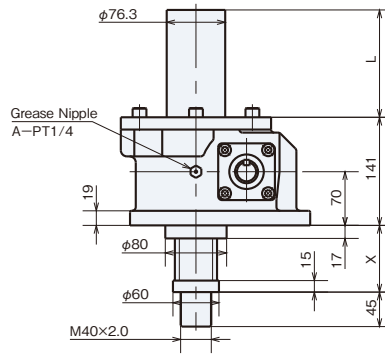
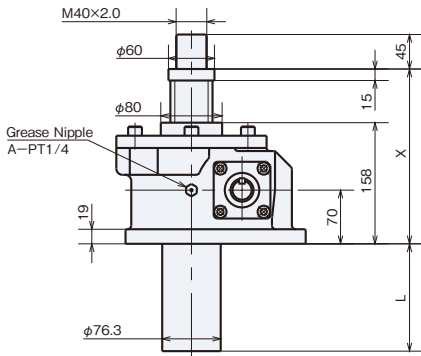

## JWM150 Dimensions - Rotation Prevention Type

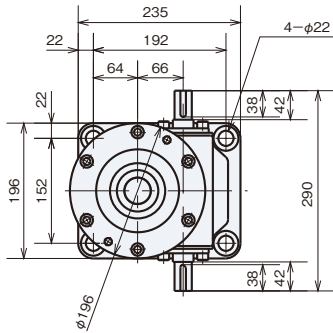

Stroke	UM Rotation Prevention Type for Lifting					DM Rotation Prevention Type for Suspending					Weight kg
	X		X		L	X		X		L	
	Without Bellows	With Bellows	Without Bellows	With Bellows		Without Bellows	With Bellows	Without Bellows	With Bellows		
MIN	MAX	MIN	MAX	MIN	MAX	MIN	MAX	MIN	MAX		
100	219	319	229	329	151	42	142	52	152	151	37
200	219	419	229	429	252	42	242	52	252	252	40
300	219	519	244	544	366	42	342	67	367	366	43
400	219	619	244	644	466	42	442	67	467	466	46
500	219	719	269	769	591	42	542	92	592	591	49
600	219	819	269	869	691	42	642	92	692	691	52
800	219	1019	284	1084	906	42	842	107	907	906	58
1000	219	1219	294	1294	1116	42	1042	117	1117	1116	64
1200	219	1419	319	1519	1341	42	1242	142	1342	1341	69
1500	219	1719	344	1844	1666	42	1542	167	1667	1666	78

Lift (JWM150UM)

Suspend (JWM150DM)

● Input Shaft

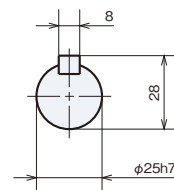
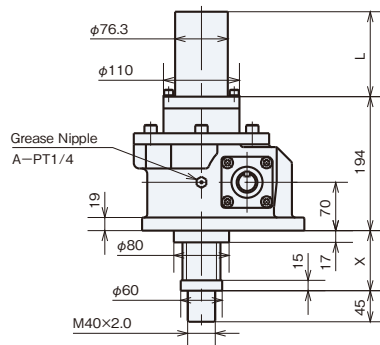
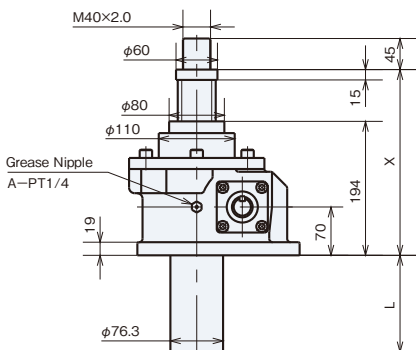

## Output Options

■ Bellows ( - J)

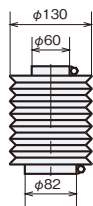

■ Rod Type End Fitting ( - B)

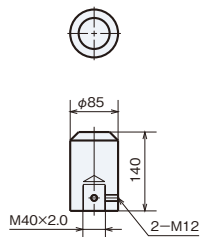

■ I Type End Fitting ( - I)

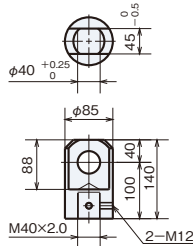

■ Table Type End Fitting ( - M)

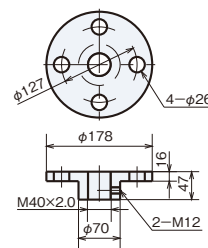

## JWM150 Dimensions - Travel Nut Type

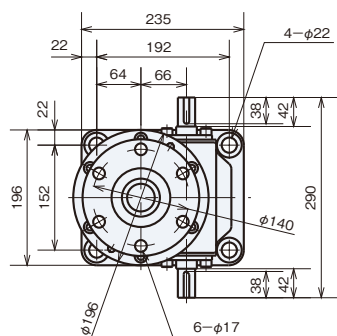

Stroke	UR Travel Nut Type for Lifting			DR Travel Nut Type for Suspending			Weight kg
	X		Y	X		Y	
	MIN	MAX		MIN	MAX		
100	214	314	379	128	228	239	40
200	214	414	479	128	328	339	42
300	214	514	579	128	428	439	43
400	214	614	679	128	528	539	45
500	214	714	779	128	628	639	46
600	214	814	879	128	728	739	48
800	214	1014	1079	128	928	939	51
1000	214	1214	1279	128	1128	1139	54
1200	214	1414	1479	128	1328	1339	57
1500	214	1714	1779	128	1628	1639	61

**Lift (JWM150UR)**

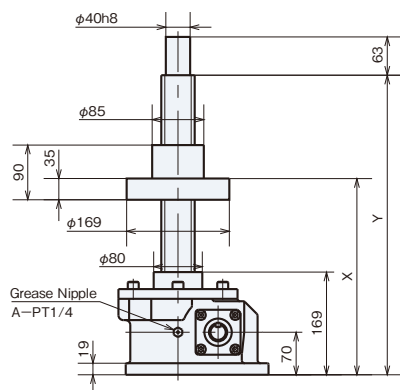

**Suspend (JWM150DR)**

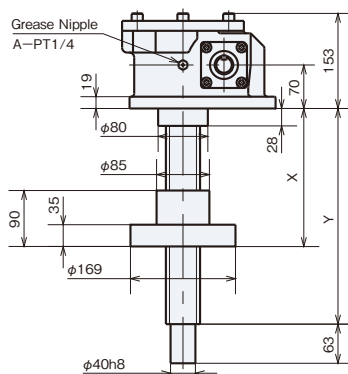

● **Input Shaft**

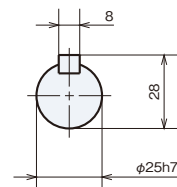

Travel nut type cannot be equipped with optional end fitting (B.I.M).  
For types with bellows, refer to page 249.

\* For dimensions with no tolerances, general tolerances shall apply, and they may be approximately 2 – 5mm larger than the dimensions shown. For machine design, take margins into consideration.

## JWM200 Dimensions - Standard Model

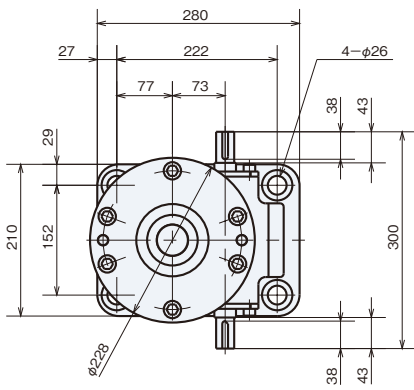

Stroke	US Standard Model for Lifting					DS Standard Model for Suspending					Weight kg
	X		X		L	X		X		L	
	Without Bellows	With Bellows	Without Bellows	With Bellows		Without Bellows	With Bellows	Without Bellows	With Bellows		
MIN	MAX	MIN	MAX		MIN	MAX	MIN	MAX			
100	203	303	213	313	136	42	142	52	152	136	42
200	203	403	213	413	236	42	242	52	252	236	45
300	203	503	228	528	351	42	342	67	367	351	49
400	203	603	228	628	451	42	442	67	467	451	53
500	203	703	253	753	576	42	542	92	592	576	57
600	203	803	253	853	676	42	642	92	692	676	60
800	203	1003	268	1068	891	42	842	107	907	891	67
1000	203	1203	278	1278	1101	42	1042	117	1117	1101	74
1200	203	1403	303	1503	1326	42	1242	142	1342	1326	81
1500	203	1703	328	1828	1651	42	1542	167	1667	1651	92
2000	203	2203	373	2373	2196	42	2042	212	2212	2196	109

Lift (JWM200US)

Suspend (JWM200DS)

● Input Shaft

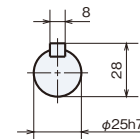
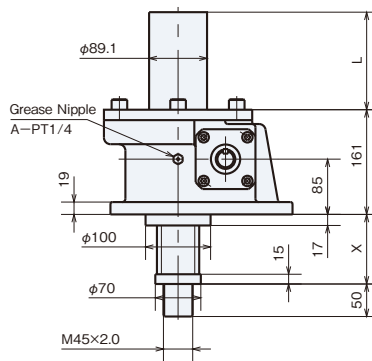
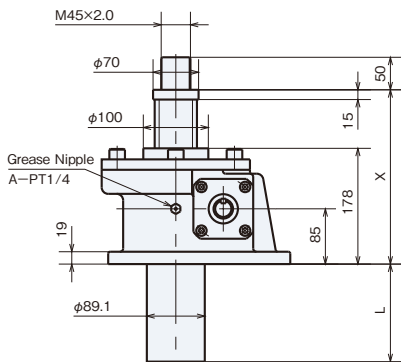

## JWM200 Dimensions - Rotation Prevention Type

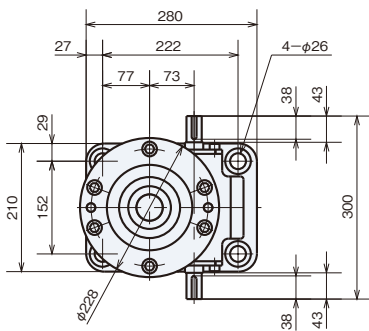

Stroke	UM Rotation Prevention Type for Lifting					DM Rotation Prevention Type for Suspending					Weight kg
	X		X		L	X		X		L	
	Without Bellows	With Bellows	Without Bellows	With Bellows		Without Bellows	With Bellows	Without Bellows	With Bellows		
MIN	MAX	MIN	MAX		MIN	MAX	MIN	MAX			
100	252	352	262	362	136	42	142	52	152	136	51
200	252	452	262	462	236	42	242	52	252	236	55
300	252	552	277	577	351	42	342	67	367	351	58
400	252	652	277	677	451	42	442	67	467	451	62
500	252	752	302	802	576	42	542	92	592	576	66
600	252	852	302	902	676	42	642	92	692	676	69
800	252	1052	317	1117	891	42	842	107	907	891	76
1000	252	1252	327	1327	1101	42	1042	117	1117	1101	83
1200	252	1452	352	1552	1326	42	1242	142	1342	1326	90
1500	252	1752	377	1877	1651	42	1542	167	1667	1651	100
2000	252	2252	422	2422	2196	42	2042	212	2212	2196	118

Lift (JWM200UM)

Suspend (JWM200DM)

● Input Shaft

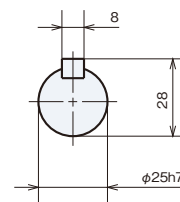
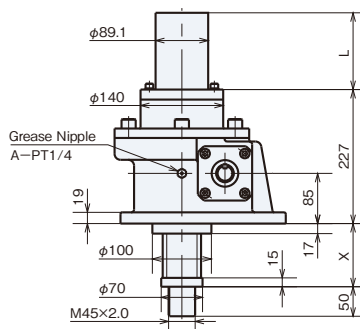
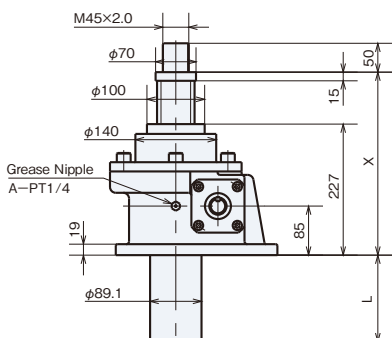

## Output Options

■ Bellows ( - J)



■ Rod Type End Fitting ( - B)

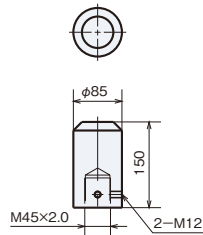

■ I Type End Fitting ( - I)

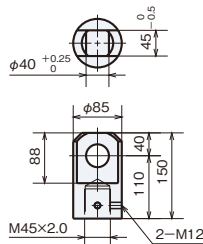

■ Table Type End Fitting ( - M)

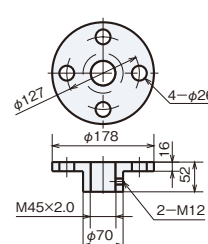

## JWM200 Dimensions - Travel Nut Type

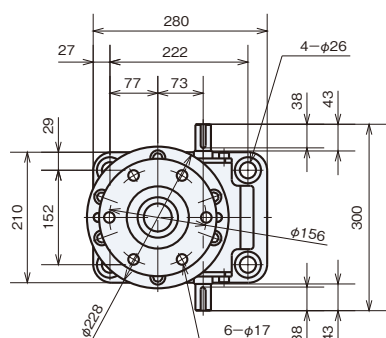

Stroke	UR Travel Nut Type for Lifting			DR Travel Nut Type for Suspending			Weight kg
	X		Y	X		Y	
	MIN	MAX		MIN	MAX		
100	237	337	422	151	251	261	56
200	237	437	522	151	351	361	58
300	237	537	622	151	451	461	60
400	237	637	722	151	551	561	62
500	237	737	822	151	651	661	64
600	237	837	922	151	751	761	66
800	237	1037	1122	151	951	961	71
1000	237	1237	1322	151	1151	1161	75
1200	237	1437	1522	151	1351	1361	79
1500	237	1737	1822	151	1651	1661	85
2000	237	2237	2322	151	2151	2161	96

**Lift (JWM200UR)**

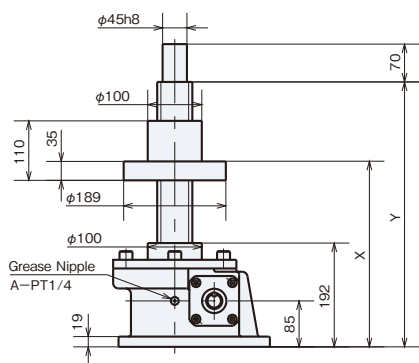

**Suspend (JWM200DR)**

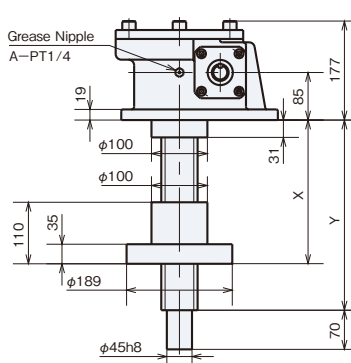

**Input Shaft**

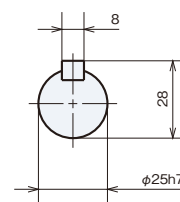

Travel nut type cannot be equipped with optional end fitting (B.I.M).  
For types with bellows, refer to page 249.

\* For dimensions with no tolerances, general tolerances shall apply, and they may be approximately 2 – 5mm larger than the dimensions shown. For machine design, take margins into consideration.

# JWM300 Dimensions - Standard Model

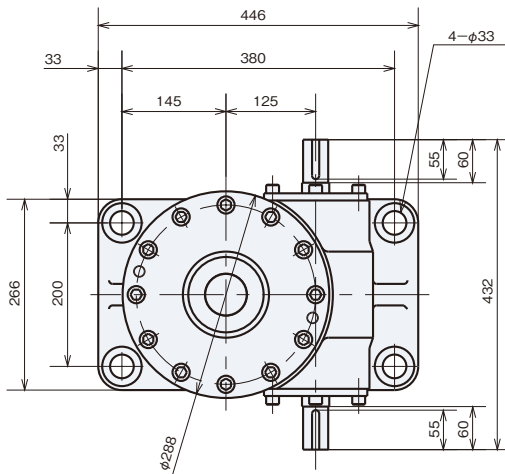

Lift (JWM300US)

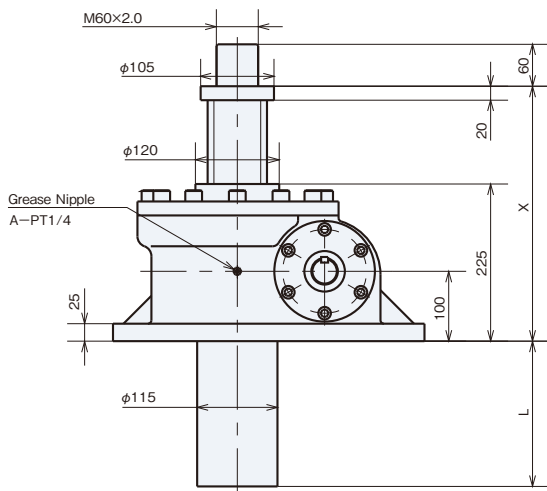

● Input Shaft

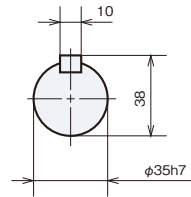

Suspend (JWM300DS)

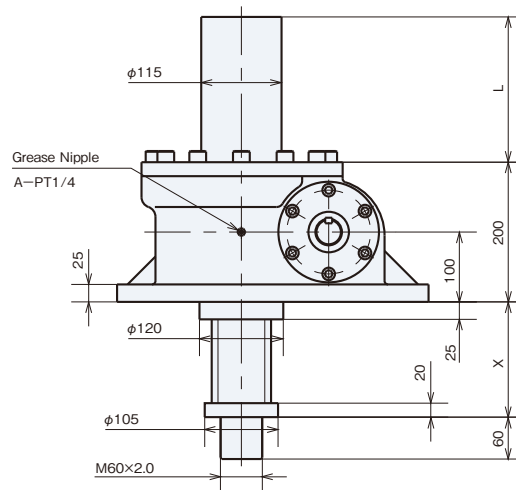

Stroke	US Standard Model for Lifting					DS Standard Model for Suspending					Weight kg
	X		X		L	X		X		L	
	Without Bellows	With Bellows	Without Bellows	With Bellows		Without Bellows	With Bellows	Without Bellows	With Bellows		
MIN	MAX	MIN	MAX		MIN	MAX	MIN	MAX			
100	255	355	265	365	135	55	155	65	165	135	118
200	255	455	265	465	235	55	255	65	265	235	123
300	255	555	280	580	350	55	355	80	380	350	128
400	255	655	280	680	450	55	455	80	480	450	134
500	255	755	295	795	565	55	555	95	595	565	139
600	255	855	295	895	665	55	655	95	695	665	145
800	255	1055	310	1110	880	55	855	110	910	880	155
1000	255	1255	330	1330	1100	55	1055	130	1130	1100	167
1200	255	1455	340	1540	1310	55	1255	140	1340	1310	177
1500	255	1755	365	1865	1635	55	1555	165	1665	1635	194
2000	255	2255	400	2400	2170	55	2055	200	2200	2170	221

For JWM300 (compact type), see page 257 - 260.

## Output Options

### ■ Bellows ( - J )

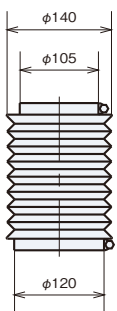

### ■ Rod Type End Fitting ( - B )

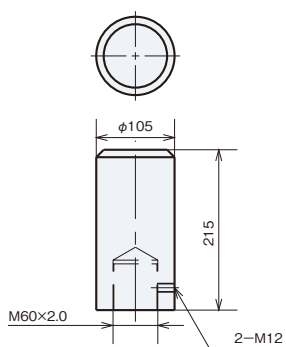

### ■ I Type End Fitting ( - I )

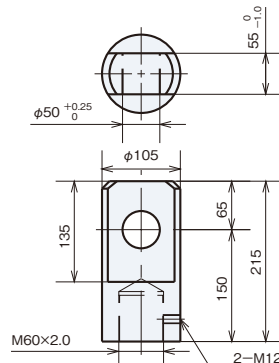

### ■ Table Type End Fitting ( - M )

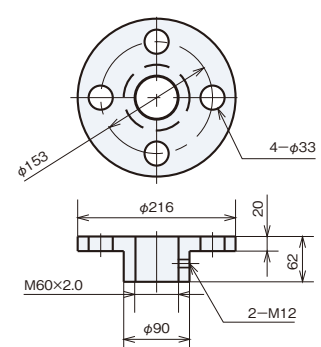



## JWM500 Dimensions - Standard Model

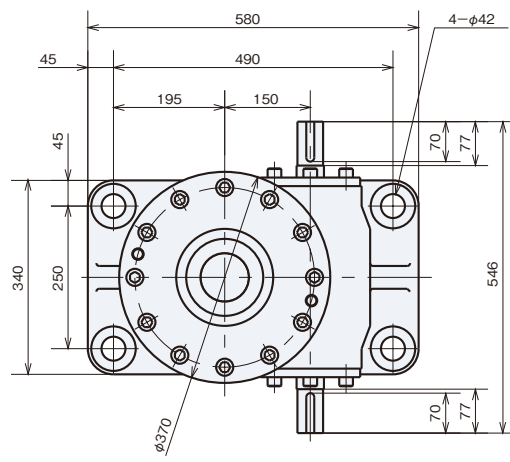

Stroke	US Standard Model for Lifting					DS Standard Model for Suspending					Weight kg
	X Without Bellows		X With Bellows		L	X Without Bellows		X With Bellows		L	
	MIN	MAX	MIN	MAX		MIN	MAX	MIN	MAX		
100	315	415	320	420	137	55	155	60	160	137	248
200	315	515	320	520	237	55	255	60	260	237	260
300	315	615	340	640	357	55	355	80	380	357	273
400	315	715	340	740	457	55	455	80	480	457	284
500	315	815	350	850	567	55	555	90	590	567	297
600	315	915	350	950	667	55	655	90	690	667	308
800	315	1115	365	1165	882	55	855	105	905	882	332
1000	315	1315	380	1380	1097	55	1055	120	1120	1097	357
1200	315	1515	390	1590	1307	55	1255	130	1330	1307	380
1500	315	1815	410	1910	1627	55	1555	150	1650	1627	417
2000	315	2315	445	2445	2162	55	2055	185	2185	2162	477

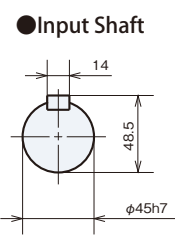

**Lift (JWM500US)**

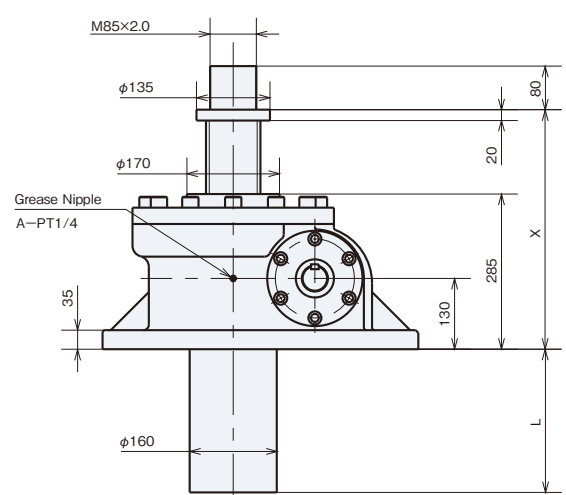

**Suspend (JWM500DS)**

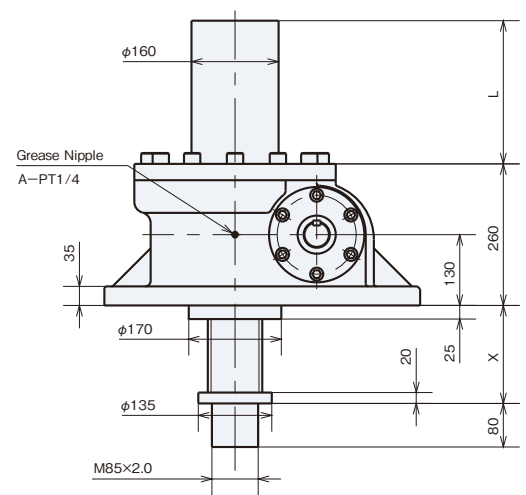

For JMMC500 (compact type), see page 257 - 260.

## Output Options

- Bellows ( - J)
- Rod Type End Fitting ( - B)
- I Type End Fitting ( - I)
- Table Type End Fitting ( - M)

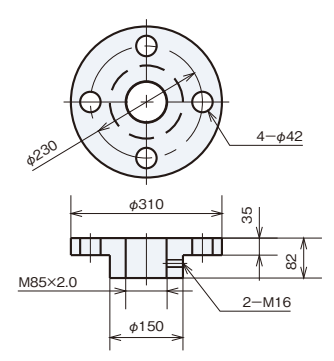
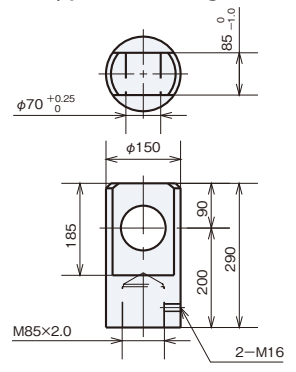
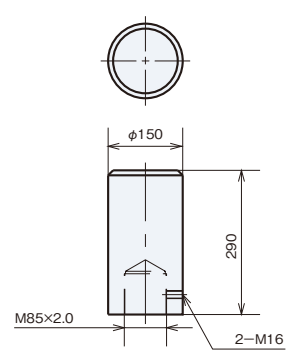
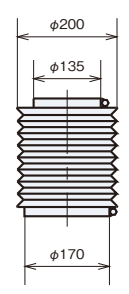

\* For dimensions with no tolerances, general tolerances shall apply, and they may be approximately 2 - 5mm larger than the dimensions shown. For machine design, take margins into consideration.



# Warning

## ■ Cautions for selecting

- Duty cycle of JWM (Machine screw type) is within 20% ED. Duty cycle is a ratio of operating time per 30 min on the basis of 30 min interval.
- Although JWM (Machine screw type) comes with a self-locking device based on calculation, it may not be effective due to vibration or shock. Separately a brake mechanism is required under such conditions.
- Activating torque for the drive unit should be maintained at 200% above the required torque.
- Allowable input rotation speed of linear power jack is 1800 r/min, however, when inputting a speed exceeding the maximum input rotation speed at the basic capacity, check the screw shaft speed (elevation speed) and allowable load related graphs on page 153.
- Select a stroke for the jack with an extra margin with respect to the used stroke.
- Rotating force is generated on the screw shaft (travel nut in the case of travel nut type) with thrust, therefore, rotation prevention is required. Screw rotation torque at the basic capacity is described in the standard specification list. When operating with the end unconnected, and pulling the rope with a sheave installed, use the rotation prevention type. However, the rotation prevention type cannot be manufactured for the travel nut type, therefore, provide a rotation prevention mechanism on the device.
- When installing a sprocket, gear, or belt to the input or output shaft, confirm that any overhang load applied to the shaft decreases to the allowable OHL or less.

$$\text{Allowable O. H. L.} \geq \frac{T \times f \times L_f}{R}$$

O.H.L. : Overhang load N {kgf}  
 T : Input torque N · m {kgf · m}  
 f : Coefficient - power transmission element  
 L<sub>f</sub> : Coefficient - Load operating position  
 R : Sprocket, Gear, V pulley or Pitch diameter m

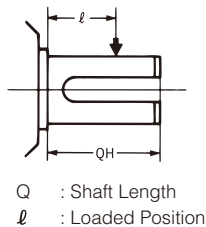

Q : Shaft Length  
 l : Loaded Position

### ● Coefficient – Power Transmission Element (f)

Sprocket	1.00
Gear	1.25
V-belt	1.50
Flat belt	2.50

### ● Coefficient (L<sub>f</sub>) – Load Position

l / QH	0.25	0.38	0.5	0.75	1
L <sub>f</sub>	0.8	0.9	1	1.5	2

### ● Allowable O.H.L

Frame No.		002	005	010	025	050	100	150	200	300	500	750	1000
JWM (Machine Screw Type)	N	99	200	380	710	1500	2270	3160	4320	6110	10100	13900	18000
H Speed	{ kgf }	{10}	{21}	{39}	{73}	{153}	{232}	{323}	{441}	{624}	{1030}	{1420}	{1840}
JWM (Machine Screw Type)	N	63	120	220	420	820	1430	1950	2800	4400	6650	9390	13200
L Speed	{ kgf }	{6}	{13}	{23}	{44}	{85}	{146}	{200}	{286}	{449}	{678}	{958}	{1350}

## ■ Precautions for installation

- Jacks that range under the basic capacity of 49.0 kN {5tf} or less are provided with screw covers made of hard vinyl chloride pipe. Never suspend or carry a jack by use of the screw cover, which is dangerous.
- JWM (Machine screw type) is not equipped with a fall stop, therefore, if the stroke range is exceeded, the screw shaft falls.
- Take jack coasting amount into consideration to set the stroke adjusting limit switch.

## ■ Precautions for use

- Do not use mechanical stops under any circumstances.
- Operating Environment for jack is as follows.

Operating place	Indoor room which cannot be splashed with rain or water.
Ambient atmosphere	Dust volume comparable to general factories.
Operating temperature range	– 15 to 80°C (Refer to section 3 in general precautions.)
Relative humidity	85% or less (no dew condensation)

- Operating part and reducer unit are factory greased. Therefore, use jack as delivered.
- For lubrication grease, lubrication cycle and lubrication amount to the screw shaft and reducer unit, refer to page 253.
- Inspect regularly for general backlash and screw unit condition. Jack life and replacement timing are determined by the following:  
 Backlash in the direction of screw shaft and nut reaches 1/4 of the screw pitch.  
 Replace gear when its input shaft exceeds 30 rpm with backlash (rattle between input shaft and worm wheel) at H speed, or exceeds 60 rpm at L speed.  
 In either case, if it is used at the replacement timing, this may cause rotation failure of screw shaft and input shaft, and further sudden drop of travel nut.

Linipower Jack

# JWB (Ball Screw Type)

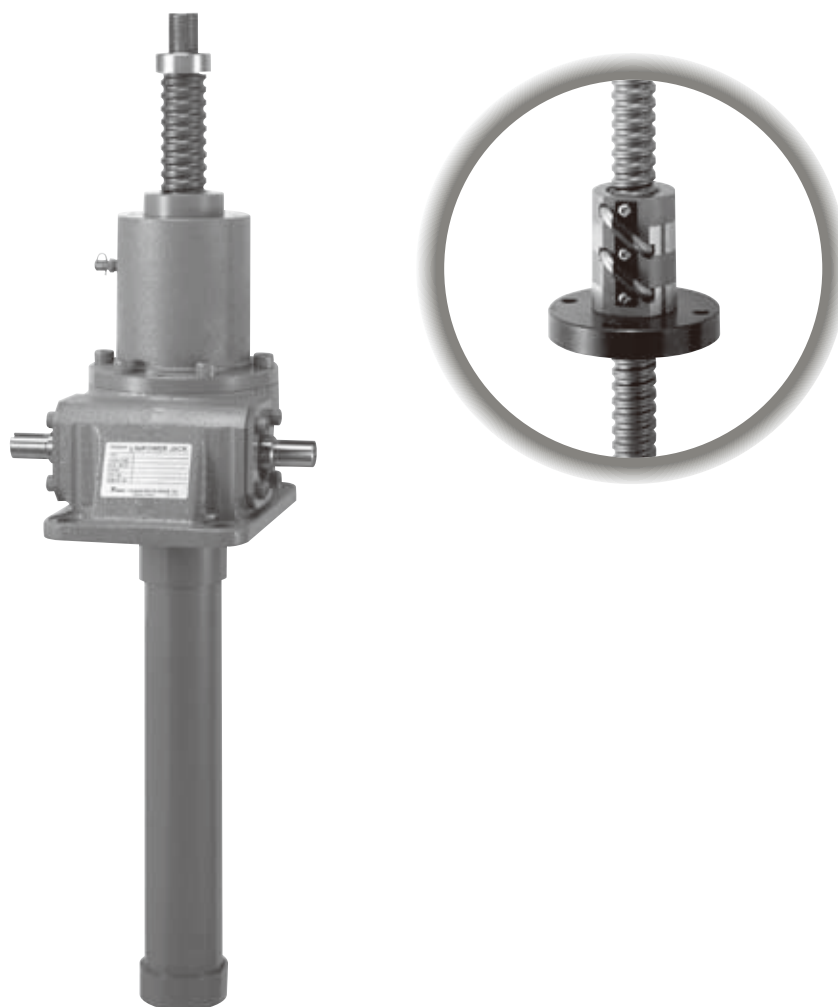

Drawings	_____	P191•192
JWB Reference Number System	_____	P193•194
Reference Table for Standard Use	_____	P195•196
Dimensions	_____	P197~212
Precautions	_____	P213

Standard Use for Lifting

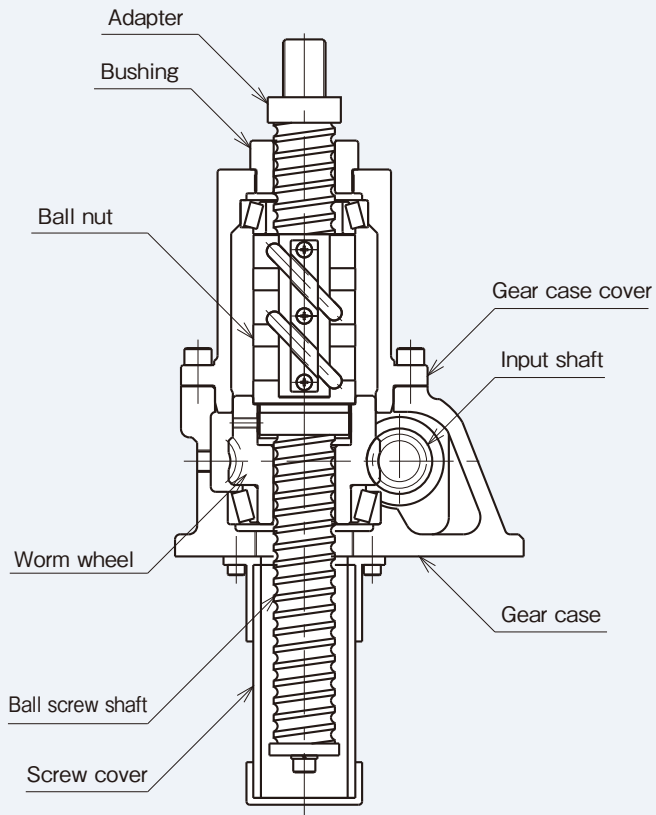

Standard Use for Suspending

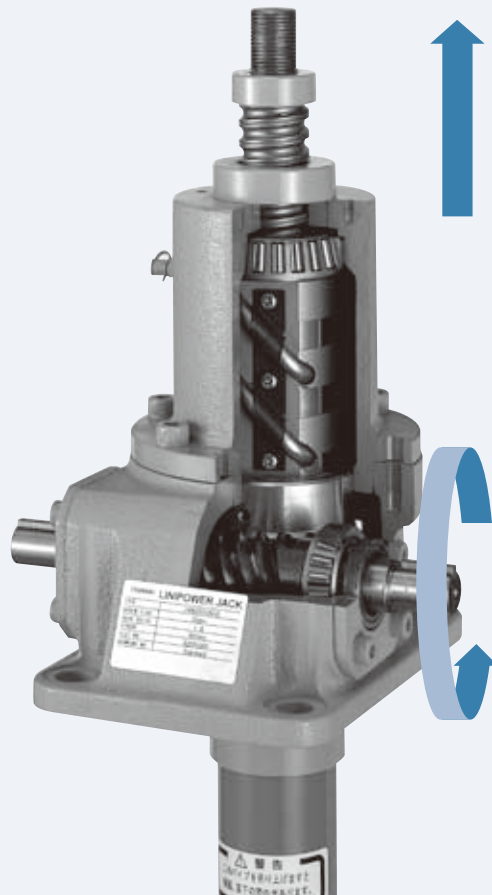
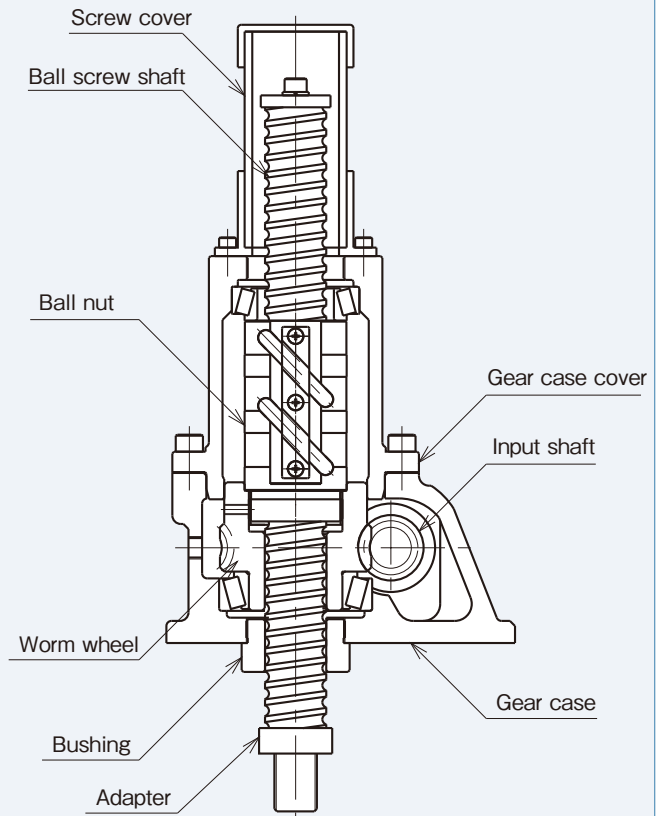

JWB (Ball Screw Type) Rotation Prevention Type

JWB005~200

〈Rotation Prevention Type with Guide Nut〉

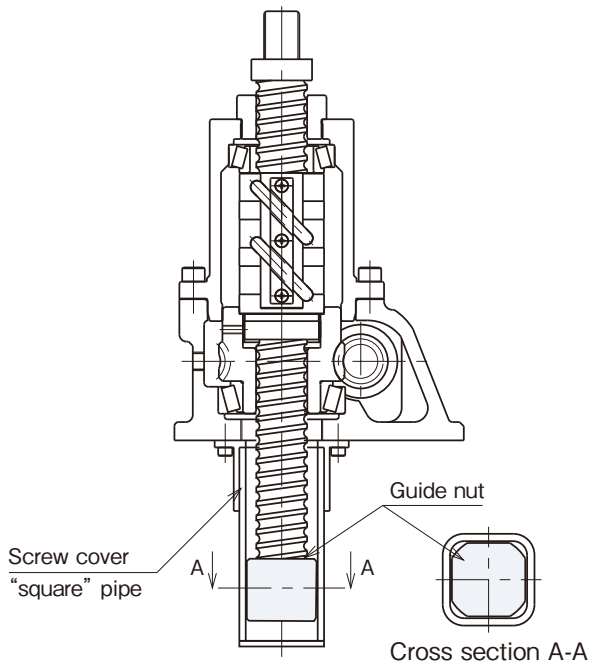

Note) The 10°space in each corner between the guide and the pipe allows smooth rotation.

JWB (Ball Screw Type) Travel Nut Type

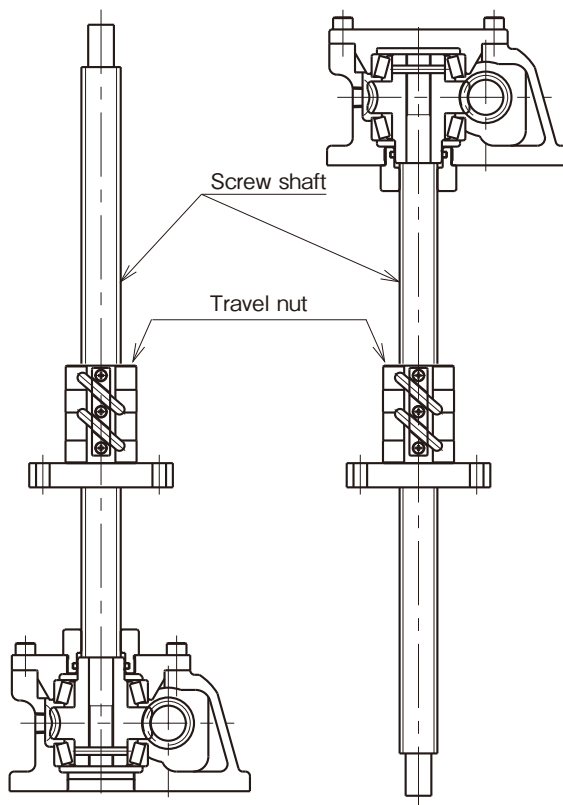

# JWB (Ball Screw Type)



Linipower Jack

Jack Type  
B : Ball screw

### Basic Capacity

Frame No.	kN	{tf}
005	4.90	{0.5}
010	9.80	{1}
025	24.5	{2.5}
050	49.0	{5}
100	98.0	{10}
150	147	{15}
200	196	{20}
300	294	{30}
500	490	{50}
750	735	{75}
1000	980	{100}

\*Compact type is available for JWM300 and 500. See page 257.

\*JWM750 and 1000 are manufactured upon inspecting specific needs.

### Installation Type

US	Standard Use - Lifting	
DS	Standard Use - Suspending	
UM	Rotation Prevention - Lifting	 (See page 192)
DM	Rotation Prevention - Suspending	 (See page 192)

### Stroke mm

1	100
3	300
6	600
10	1000

\*The above values are examples. For actual stroke used, refer to the Model comparison Table for JWB on page 145.

### Gear Ratio

Symbol Frame No.	H	L
005	5	20
010	5	20
025	6	24
050	6	24
100	8	24
150	8	24
200	8	24
300	10 <sup>2</sup> / <sub>3</sub>	32
500	10 <sup>2</sup> / <sub>3</sub>	32
750	10 <sup>2</sup> / <sub>3</sub>	32
1000	12	36

### Flange Installation

U	
D	

\*Be sure to use the flange installation method U or D with travel nuts.

\*Above are only necessary with travel nuts.

Examples)





**JWB100UMH3**

- Machine Screw Type • 98.0kN {10tf} • Rotation prevention (for lifting) • Gear ratio H (1/8) • Stroke 300mm

**JWB050USH10JMK4PG2**

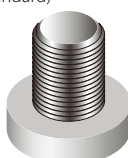
- Machine Screw Type • 49.0kN {5tf} • Standard use (for lifting) • Gear ratio H (1/6) • Stroke 1000mm
- Bellows • Table Type End Fitting • 4 Internal LS • Potentiometer
- 3 Phase motor with brake and gear; reducer ratio of 1/10

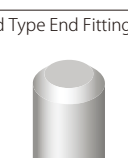
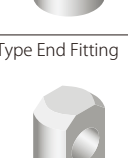
Output Option

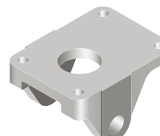

No symbol	Screw Shaft End (standard) 
J	Bellows 
B	Rod Type End Fitting 
I	I Type End Fitting 
M	Table Type End Fitting 

Installation Option

C	Clevis Mounting Adapter  (See page 245)
---	---



Note) For standard lifting only.

Sensor Option

Y	LS Counter  (See page 239)
K2 K4 P R	Position Sensor K2...2 Internal LS K4...4 Internal LS P...Potentiometer R...Rotary Encoder  (See page 241)

Note) To request the above parts, provide their letter symbols in the order given.

Input Option

E EV	3 phase brake and motor E...200V 50Hz 200/220V 60Hz EV...400 50Hz 400/440V 60Hz  (See page 229~)
G1 G2	3 phase brake and gear-motor G1...Gear ratio 1/5 200V 50Hz 200/220V 60Hz G2...Reducer ratio 1/10 200V 50Hz 200/220V 60Hz  (See page 229~)

Accessories

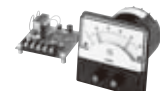
<b>Control Options</b>
Stroke Meter and PCB 
Meter Relay and PCB  (See page 242~)
<b>Others</b>
Trunnion Mounting Adapter  * Use as a set with clevis mounting adapter. (See page 245)

Note) To request the above parts, provide their letter symbols in the order given. When travel nuts are used, B, I and M are not required.

Note) Travel nut type with bellows is estimated for each order. Enter necessary information in the inquiry form on page 249 to contact TSUBAKI E&M.



## Reference Table for Standard Use JWB (Ball Screw Type)

Frame No.		JWB005	JWB010	JWB025	JWB050	JWB100
Basic Capacity	kN	4.90	9.80	24.5	49.0	98.0
	{tf}	{0.5}	{1}	{2.5}	{5}	{10}
Outer Screw Diameter	mm	16	20	25	36	45
Minor Screw Diameter	mm	13.5	17.5	21.4	31.3	39.1
Screw Lead	mm	5	5	8	10	12
Gear Ratio	H Speed	5	5	6	6	8
	L Speed	20	20	24	24	24
Overall Efficiency	H Speed	63	61	62	64	63
	L Speed	37	34	35	39	43
Max. Allowable Input Capacity	H Speed	0.25	0.54	1.3	2.2	3.6
	L Speed	0.12	0.27	0.63	1.0	1.9
Tare Drag Torque	N·m	0.11	0.29	0.62	1.37	1.96
	{kg·m}	{0.011}	{0.03}	{0.063}	{0.14}	{0.2}
Holding Torque	H Speed	0.69	1.27	4.31	10.78	19.6
	N·m {kgf·m}	{0.07}	{0.13}	{0.44}	{1.1}	{2.0}
	L Speed	0.14	0.26	0.91	2.4	5.8
	{kgf·m}	{0.014}	{0.027}	{0.093}	{0.24}	{0.59}
Allowable Input Torque *Note 1	N·m	9.8	19.6	49.0	153.9	292.0
	{kg·m}	{1}	{2}	{5}	{15.7}	{29.8}
Required Input Torque *Note 2 for Basic Capacity	H Speed	1.3	2.8	9.0	21.5	39.1
	N·m {kgf·m}	{0.14}	{0.29}	{0.92}	{2.2}	{4.0}
	L Speed	0.62	1.4	4.3	9.6	20.4
	{kgf·m}	{0.06}	{0.15}	{0.44}	{0.98}	{2.1}
Screw Movement/ per Revolution of Input Shaft	H Speed	1	1	1.33	1.67	1.5
	mm					
Max. Input rpm	H Speed	1800	1800	1800	1800	1800
	r/min					
Max. Input rpm for Basic Capacity	H Speed	1800	1800	1400	1000	890
	r/min					
Screw Shaft Rotational Torque for Basic Capacity	H Speed	4.3	8.7	34.7	86.7	208.2
	N·m {kgf·m}	{0.44}	{0.88}	{3.5}	{8.8}	{21.2}
Screw Cover Material *Note 3		Hard Vinyl Chloride				Steel Pipe
Lubrication		Shaft: Grease Reducer Unit: Grease Bath				
Color		Tsubaki Olive Grey (Munsell 5GY6/0.5)				
Environment	Operating Temperature Range	- 15 to 80°C (Precautions #2)				
	Relative Humidity	85% or less (no dew condensation)				
	Operating ambient atmosphere	Indoor Environment (Indoor room where rain and water cannot enter. Dust volume should be normal.)				
Duty Cycle *Note 4		Within 30% ED				

Note 1) The allowable torque is for jack input shaft only. (Reconfirm if synchronous drive.)

Note 2) Includes tare drag torque.

Note 3) Rotation prevention types for frames 005~050 are steel square pipes.

Note 4) Standard percentage duty cycle is 30 minutes. Thus, driving time is based on 30minute intervals.

### Precautions

1. All loads (static, dynamic or shock) should be within the rated capacity of the jack at sufficient safety levels.
2. Operating Temperature Range refers to the surface temperature of the jack during operation. To check, measure the surface temperature of the input shaft unit or travel nut (if used). Be sure all the rotating parts have completely stopped before proceeding to measure.
3. Be sure to operate within the allowable input rpm of 1800/min.
4. Number of synchronizing jacks which can be connected on the same line is limited by shaft strength. Refer to the allowable input shaft torque on the above table.
5. Activating torque for the drive unit should be maintained at 200% above the required torque.
6. If operating in freezing temperatures, a change in viscosity may reduce the efficiency of the grease. Set the drive unit so as to accommodate this change.

JWB150	JWB200	JWB300	JWB500	JWB750	JWB1000
147	196	294	490	735	980
{15}	{20}	{30}	{50}	{75}	{100}
50	63	85	100	125	140
43.1	55.7	74.8	87	112	122
16	16	20	24	25	32
8	8	10 2/3	10 2/3	10 2/3	12
24	24	32	32	32	36
63	62	56	60	57	54
43	41	34	38	36	32
4.0	5.5	8.9	13.3	16.1	21.2
2.1	2.8	4.1	6.5	8.2	10.2
2.65	3.92	9.81	19.6	29.4	39.2
{0.27}	{0.4}	{1}	{2}	{3}	{4}
39.2	51.0	68.6	140.1	210.7	362.6
{4.0}	{5.2}	{7.0}	{14.3}	{21.5}	{37}
11.8	15.0	19.5	41.2	59.8	99.0
{1.2}	{1.53}	{1.99}	{4.2}	{6.1}	{10.1}
292.0	292.0	735.0	1372.0	1764.0	2450.0
{29.8}	{29.8}	{75}	{140}	{180}	{250}
77.0	104.5	169.6	317.5	511.2	810.2
{7.8}	{10.7}	{17.3}	{32.4}	{52.1}	{82.6}
39.6	54.2	98.5	177.9	290.8	486.9
{4.0}	{5.5}	{10.0}	{18.1}	{29.6}	{49.6}
2	2	1.88	2.25	2.34	2.67
0.67	0.67	0.63	0.75	0.78	0.89
1800	1800	1800	1800	1800	1800
1800	1800	1800	1800	1800	1800
500	500	500	400	300	250
500	500	400	350	270	200
416.3	555.1	1040.9	2081.7	3252.7	5551.3
{42.4}	{56.6}	{106.1}	{212.2}	{331.6}	{565.9}
Steel Pipe					
Screw: Grease Reducer Unit: Grease Bath					
Tsubaki Olive Grey (Munsell 5GY6/0.5)					
- 15 to 80°C (Precautions #2)					
85% or less (no dew condensation)					
Indoor Environment (Indoor room where rain and water cannot enter. Dust volume should be normal.)					
Within 30% ED					

7. Since JWB (Ball Screw Type) is highly efficient, sufficient brake that over powers the "holding torque" is required to sustain its shaft.

⚠8. Be certain that the jack rating exceeds the maximum stroke. Over travel can cause the lift shaft to disengage from the ball nut. JWB (Ball Screw Type) is supported by a stopper (shaft end). However, this is merely for the purpose of securing the screw shaft during installation. While installing, take caution so that the screw shaft does not rotate by its own weight and

become disengaged. If rotation cannot be avoided, use a model with rotation prevention. (Contact TEM for details.)

⚠9. Do not use mechanical stops under any circumstances. This will cause major internal damage.

10. Input shaft key is provided with each unit. (The input shaft key complies with JIS B 1301-1996 (normal grade).)

## JWB005 Dimensions - Standard Model

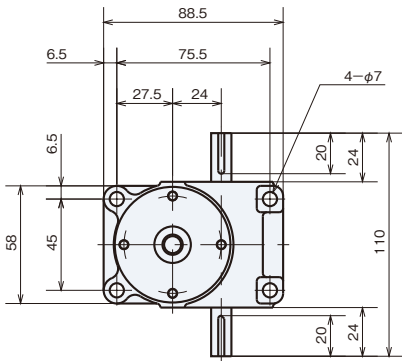

Stroke	US Standard Model for Lifting					DS Standard Model for Suspending					Weight kg
	X		X		L	X		X		L	
	Without Bellows	With Bellows	Without Bellows	With Bellows		Without Bellows	With Bellows	Without Bellows	With Bellows		
MIN	MAX	MIN	MAX		MIN	MAX	MIN	MAX			
100	115	215	160	260	188	20	120	65	165	188	3.0
200	115	315	160	360	288	20	220	65	265	288	3.2
300	115	415	200	500	428	20	320	105	405	428	3.4
400	115	515	200	600	528	20	420	105	505	528	3.6
500	115	615	235	735	663	20	520	140	640	663	3.8
600	115	715	235	835	763	20	620	140	740	763	4.0
800	115	915	270	1070	998	20	820	175	975	998	4.3

Lift (JWB005US)

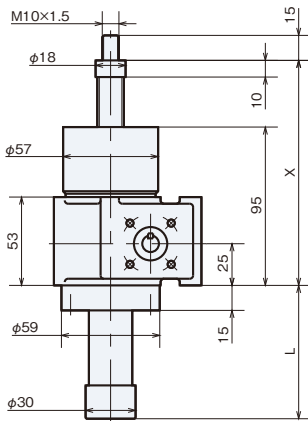

Suspend (JWB005DS)

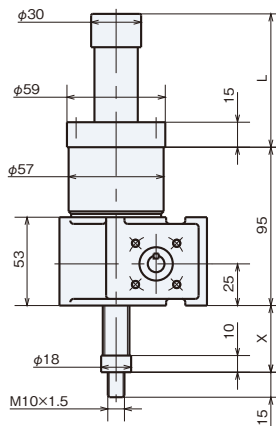

● Input Shaft

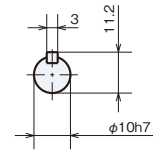

## JWB005 Dimensions - Rotation Prevention Type

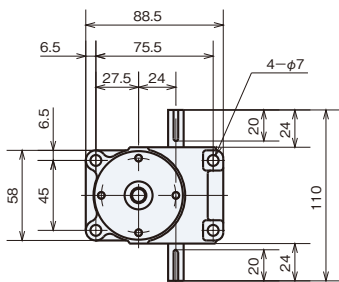

Stroke	UM Rotation Prevention Type for Lifting					DM Rotation Prevention Type for Suspending					Weight kg
	X		X		L	X		X		L	
	Without Bellows	With Bellows	Without Bellows	With Bellows		Without Bellows	With Bellows	Without Bellows	With Bellows		
MIN	MAX	MIN	MAX		MIN	MAX	MIN	MAX			
100	115	215	160	260	202	20	120	65	165	202	3.5
200	115	315	160	360	302	20	220	65	265	302	3.9
300	115	415	200	500	442	20	320	105	405	442	4.5
400	115	515	200	600	542	20	420	105	505	542	5.0
500	115	615	235	735	677	20	520	140	640	677	5.5
600	115	715	235	835	777	20	620	140	740	777	6.0
800	115	915	270	1070	1012	20	820	175	975	1012	7.0

Lift (JWB005UM)

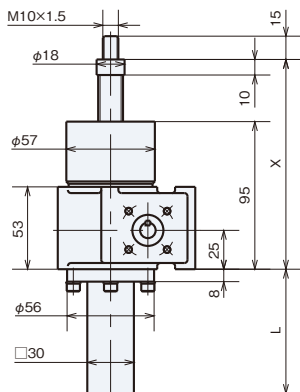

Suspend (JWB005DM)

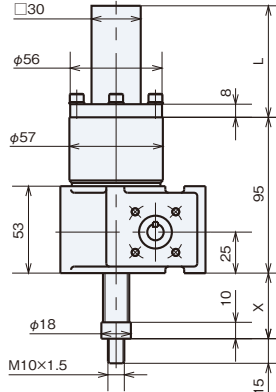

● Input Shaft

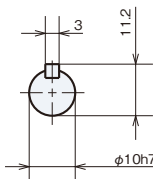

## Output Options

■ Bellows ( - J)

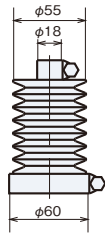

■ Rod Type End Fitting ( - B)

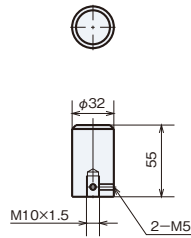

■ I Type End Fitting ( - I)

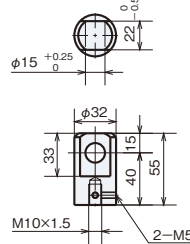

■ Table Type End Fitting ( - M)

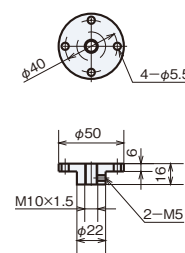

Note) For detailed measurements on units with bellows, see page 248.

## JWB005 Dimensions - Travel Nut Type

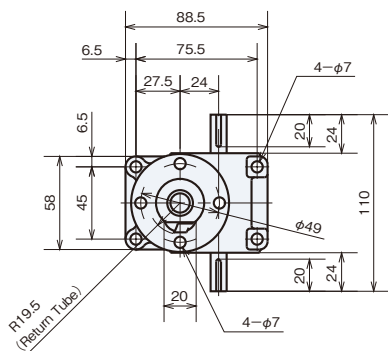

Stroke	UR Travel Nut Type for Lifting			DR Travel Nut Type for Suspending			Weight kg
	X		Y	X		Y	
	MIN	MAX		MIN	MAX		
100	84	184	224	51	151	162	2.7
200	84	284	324	51	251	262	2.8
300	84	384	424	51	351	362	2.9
400	84	484	524	51	451	462	3.1
500	84	584	624	51	551	562	3.2
600	84	684	724	51	651	662	3.3
800	84	884	924	51	851	862	3.6

**Lift (JWB005UR)**

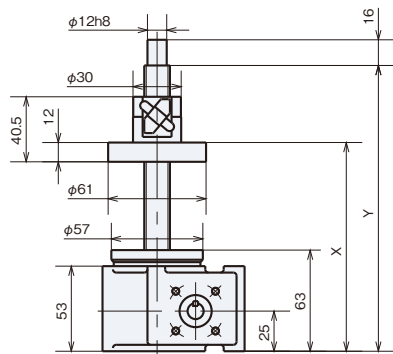

**Suspend (JWB005DR)**

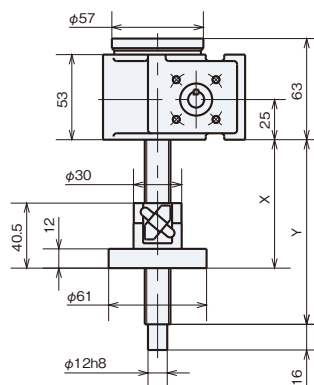

● **Input Shaft**

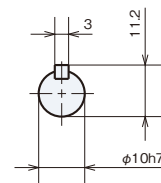

Note) Ball nut return tube and travel flange openings may vary from this drawing. Note the return tube measurements when installing to equipment.

Travel nut type cannot be equipped with optional end fitting (B.I.M). For types with bellows, refer to page 249.

\* For dimensions with no tolerances, general tolerances shall apply, and they may be approximately 2 – 5mm larger than the dimensions shown. For machine design, take margins into consideration.

## JWB010 Dimensions - Standard Model

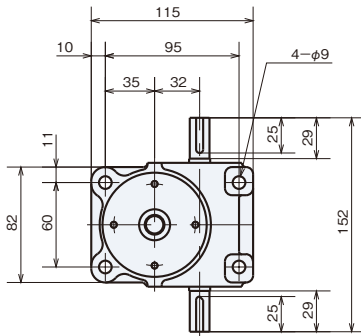

Stroke	US Standard Model for Lifting					DS Standard Model for Suspending					Weight kg
	X		X		L	X		X		L	
	Without Bellows	With Bellows	Without Bellows	With Bellows		Without Bellows	With Bellows	Without Bellows	With Bellows		
MIN	MAX	MIN	MAX		MIN	MAX	MIN	MAX			
100	162	262	212	312	194	25	125	75	175	194	6.7
200	162	362	212	412	294	25	225	75	275	294	7.0
300	162	462	252	552	434	25	325	115	415	434	7.4
400	162	562	252	652	534	25	425	115	515	534	7.6
500	162	662	287	787	669	25	525	150	650	669	8.0
600	162	762	287	887	769	25	625	150	750	769	8.2
800	162	962	322	1122	1004	25	825	185	985	1004	8.9
1000	162	1162	352	1352	1234	25	1025	215	1215	1234	9.5

Lift (JWB010US)

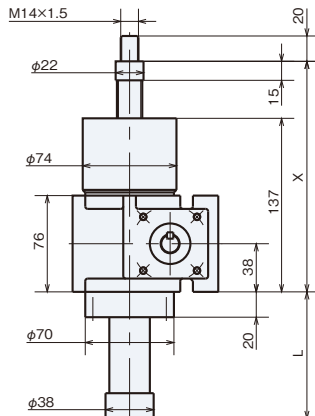

Suspend (JWB010DS)

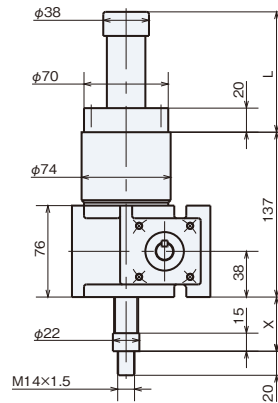

● Input Shaft

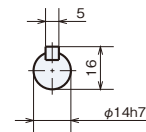

## JWB010 Dimensions - Rotation Prevention Type

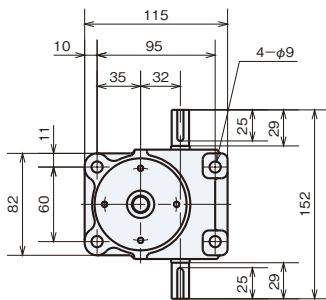

Stroke	UM Rotation Prevention Type for Lifting					DM Rotation Prevention Type for Suspending					Weight kg
	X		X		L	X		X		L	
	Without Bellows	With Bellows	Without Bellows	With Bellows		Without Bellows	With Bellows	Without Bellows	With Bellows		
MIN	MAX	MIN	MAX		MIN	MAX	MIN	MAX			
100	162	262	212	312	213	25	125	75	175	213	7.5
200	162	362	212	412	313	25	225	75	275	313	8.2
300	162	462	252	552	453	25	325	115	415	453	9.1
400	162	562	252	652	553	25	425	115	515	553	9.8
500	162	662	287	787	688	25	525	150	650	688	11
600	162	762	287	887	788	25	625	150	750	788	12
800	162	962	322	1122	1023	25	825	185	985	1023	13
1000	162	1162	352	1352	1253	25	1025	215	1215	1253	15

Lift (JWB010UM)

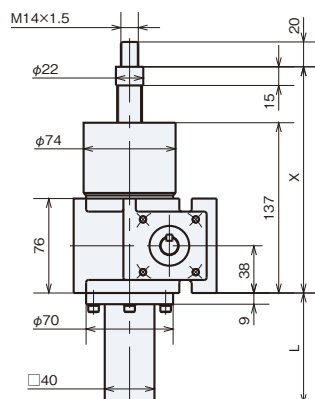

Suspend (JWB010DM)

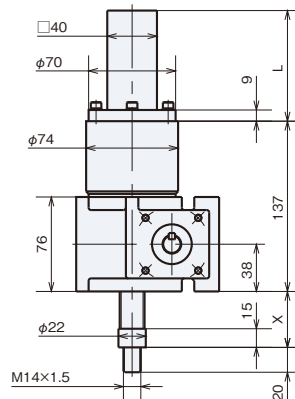

● Input Shaft

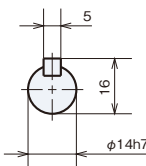

# Output Options

■ Bellows ( - J)

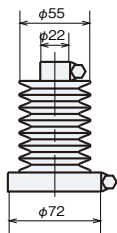

■ Rod Type End Fitting ( - B)

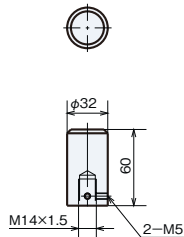

■ I Type End Fitting ( - I)

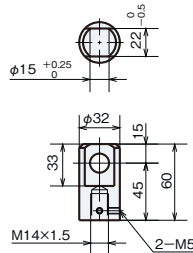

■ Table Type End Fitting ( - M)

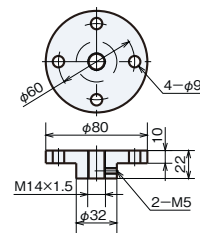

Note) For detailed measurements on units with bellows, see page 248.

## JWB010 Dimensions - Travel Nut Type

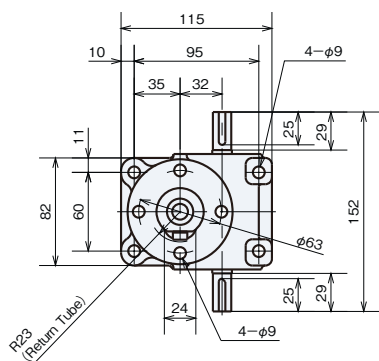

Stroke	UR Travel Nut Type for Lifting			DR Travel Nut Type for Suspending			Weight kg
	X		Y	X		Y	
	MIN	MAX		MIN	MAX		
100	108	208	265	69	169	179	5.9
200	108	308	365	69	269	279	6.1
300	108	408	465	69	369	379	6.4
400	108	508	565	69	469	479	6.6
500	108	608	665	69	569	579	6.8
600	108	708	765	69	669	679	7.0
800	108	908	965	69	869	879	7.4
1000	108	1108	1165	69	1069	1079	7.9

Lift (JWB010UR)

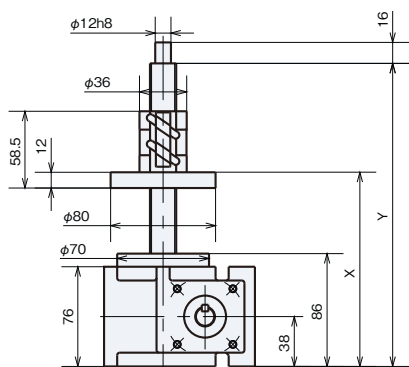

Suspend (JWB010DR)

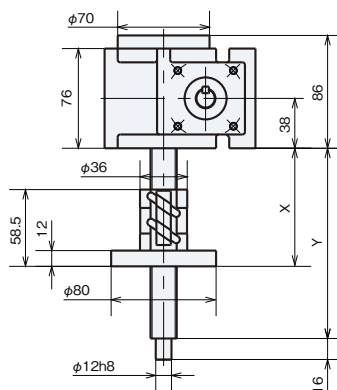

● Input Shaft

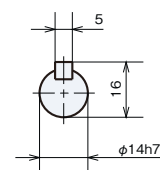

Note) Ball nut return tube and travel flange openings may vary from this drawing. Note the return tube measurements when installing to equipment.

Travel nut type cannot be equipped with optional end fitting (B.I.M). For types with bellows, refer to page 249.

\* For dimensions with no tolerances, general tolerances shall apply, and they may be approximately 2 – 5mm larger than the dimensions shown. For machine design, take margins into consideration.

## JWB025 Dimensions - Standard Model

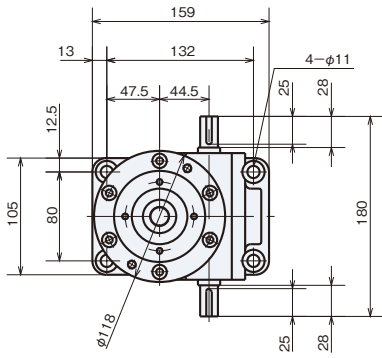

Stroke	US Standard Model for Lifting					DS Standard Model for Suspending					Weight kg
	X		X		L	X		X		L	
	Without Bellows	With Bellows	Without Bellows	With Bellows		Without Bellows	With Bellows	Without Bellows	With Bellows		
MIN	MAX	MIN	MAX		MIN	MAX	MIN	MAX			
100	215	315	230	330	149	42	142	57	157	149	11
200	215	415	230	430	249	42	242	57	257	249	11
300	215	515	250	550	369	42	342	77	377	369	11
400	215	615	250	650	469	42	442	77	477	469	12
500	215	715	270	770	589	42	542	97	597	589	12
600	215	815	270	870	689	42	642	97	697	689	13
800	215	1015	290	1090	909	42	842	117	917	909	14
1000	215	1215	310	1310	1129	42	1042	137	1137	1129	14
1200	215	1415	325	1525	1344	42	1242	152	1352	1344	15

Lift (JWB025US)

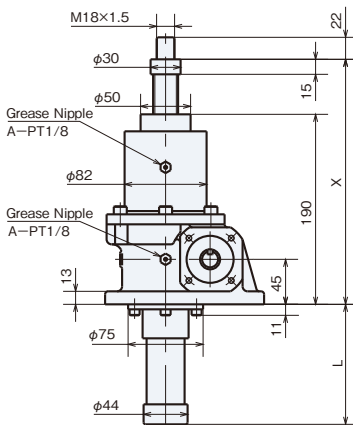

Suspend (JWB025DS)

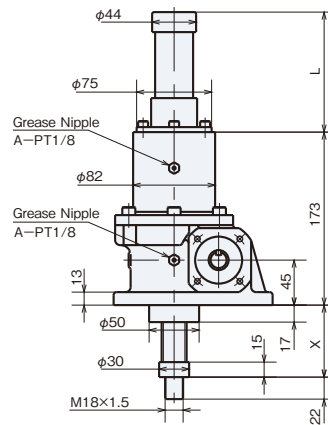

● Input Shaft

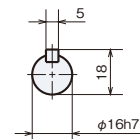

## JWB025 Dimensions - Rotation Prevention Type

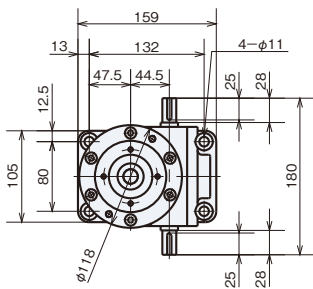

Stroke	UM Rotation Prevention Type for Lifting					DM Rotation Prevention Type for Suspending					Weight kg
	X		X		L	X		X		L	
	Without Bellows	With Bellows	Without Bellows	With Bellows		Without Bellows	With Bellows	Without Bellows	With Bellows		
MIN	MAX	MIN	MAX		MIN	MAX	MIN	MAX			
100	215	315	230	330	181	42	142	57	157	181	12
200	215	415	230	430	281	42	242	57	257	281	13
300	215	515	250	550	401	42	342	77	377	401	15
400	215	615	250	650	501	42	442	77	477	501	16
500	215	715	270	770	621	42	542	97	597	621	17
600	215	815	270	870	721	42	642	97	697	721	18
800	215	1015	290	1090	941	42	842	117	917	941	21
1000	215	1215	310	1310	1161	42	1042	137	1137	1161	23
1200	215	1415	325	1525	1376	42	1242	152	1352	1376	26

Lift (JWB025UM)

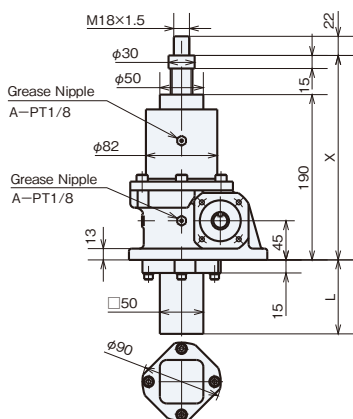

Suspend (JWB025DM)

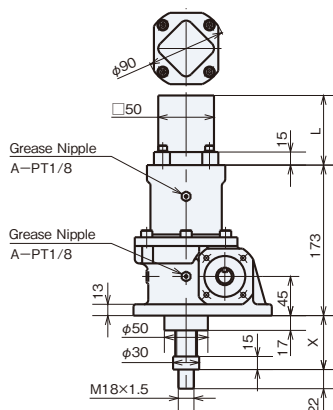

● Input Shaft

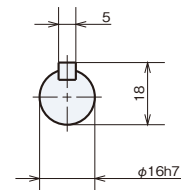



# Output Options

■ Bellows ( - J)

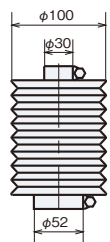

■ Rod Type End Fitting ( - B)

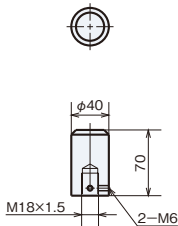

■ I Type End Fitting ( - I)

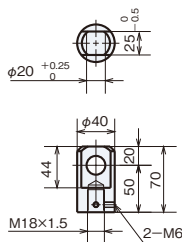

■ Table Type End Fitting ( - M)

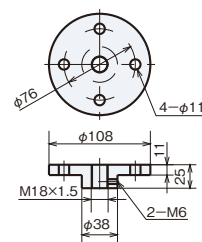

# JWB025 Dimensions - Travel Nut Type

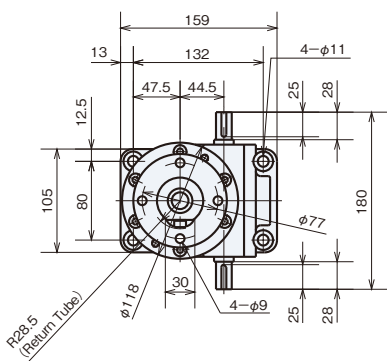

Stroke	UR Travel Nut Type for Lifting			DR Travel Nut Type for Suspending			Weight kg
	X		Y	X		Y	
	MIN	MAX		MIN	MAX		
100	133	233	309	108	208	219	9.2
200	133	333	409	108	308	319	9.5
300	133	433	509	108	408	419	9.8
400	133	533	609	108	508	519	11
500	133	633	709	108	608	619	11
600	133	733	809	108	708	719	11
800	133	933	1009	108	908	919	12
1000	133	1133	1209	108	1108	1119	13
1200	133	1333	1409	108	1308	1319	13

**Lift (JWB025UR)**

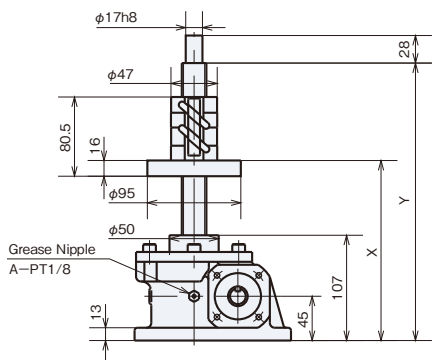

**Suspend (JWB025DR)**

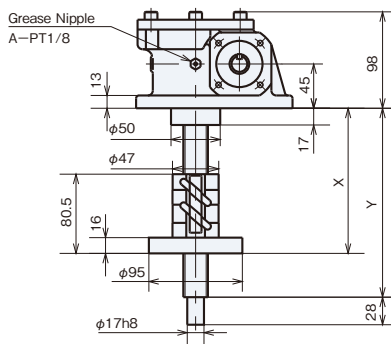

**● Input Shaft**

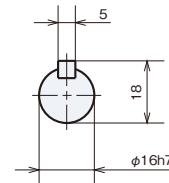

Note) Ball nut return tube and travel flange openings may vary from this drawing.  
Note the return tube measurements when installing to equipment.

Travel nut type cannot be equipped with optional end fitting (B.I.M).  
For types with bellows, refer to page 249.

\* For dimensions with no tolerances, general tolerances shall apply, and they may be approximately 2 – 5mm larger than the dimensions shown. For machine design, take margins into consideration.

## JWB050 Dimensions - Standard Model

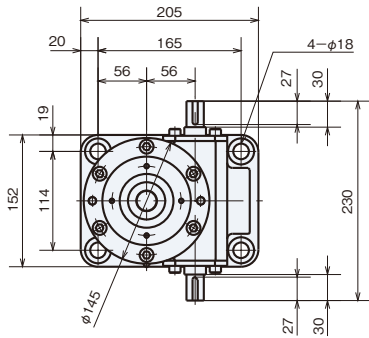

Stroke	US Standard Model for Lifting					DS Standard Model for Suspending					Weight kg
	X		X		L	X		X		L	
	Without Bellows	With Bellows	Without Bellows	With Bellows		Without Bellows	With Bellows	Without Bellows	With Bellows		
MIN	MAX	MIN	MAX		MIN	MAX	MIN	MAX			
100	269	369	284	384	147	42	142	57	157	147	23
200	269	469	284	484	247	42	242	57	257	247	23
300	269	569	304	604	367	42	342	77	377	367	24
400	269	669	304	704	467	42	442	77	477	467	25
500	269	769	324	824	587	42	542	97	597	587	26
600	269	869	324	924	687	42	642	97	697	687	27
800	269	1069	344	1144	907	42	842	117	917	907	29
1000	269	1269	364	1364	1127	42	1042	137	1137	1127	30
1200	269	1469	379	1579	1342	42	1242	152	1352	1342	32
1500	269	1769	404	1904	1667	42	1542	177	1677	1667	35

Lift (JWB050US)

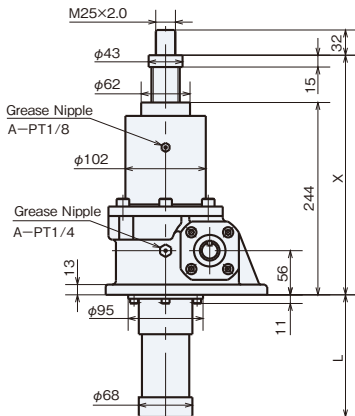

Suspend (JWB050DS)

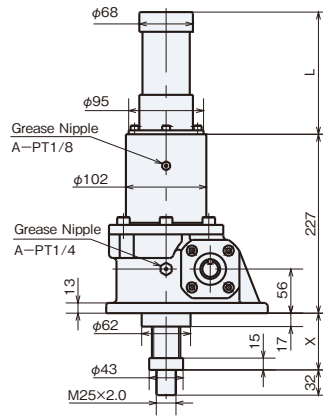

● Input Shaft

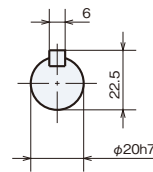

## JWB050 Dimensions - Rotation Prevention Type

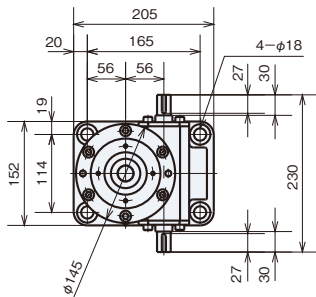

Stroke	UM Rotation Prevention Type for Lifting					DM Rotation Prevention Type for Suspending					Weight kg
	X		X		L	X		X		L	
	Without Bellows	With Bellows	Without Bellows	With Bellows		Without Bellows	With Bellows	Without Bellows	With Bellows		
MIN	MAX	MIN	MAX		MIN	MAX	MIN	MAX			
100	269	369	284	384	196	42	142	57	157	196	25
200	269	469	284	484	296	42	242	57	257	296	27
300	269	569	304	604	416	42	342	77	377	416	29
400	269	669	304	704	516	42	442	77	477	516	31
500	269	769	324	824	636	42	542	97	597	636	33
600	269	869	324	924	736	42	642	97	697	736	35
800	269	1069	344	1144	956	42	842	117	917	956	39
1000	269	1269	364	1364	1176	42	1042	137	1137	1176	43
1200	269	1469	379	1579	1391	42	1242	152	1352	1391	47
1500	269	1769	404	1904	1716	42	1542	177	1677	1716	52

Lift (JWB050UM)

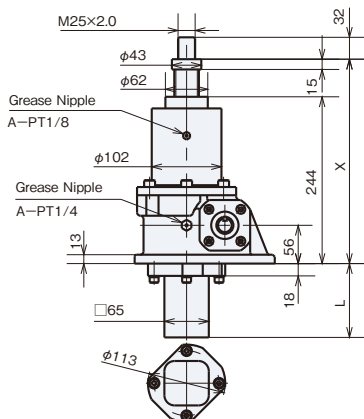

Suspend (JWB050DM)

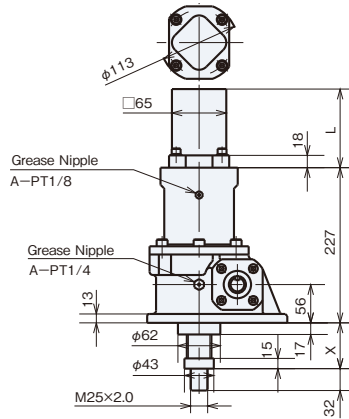

● Input Shaft

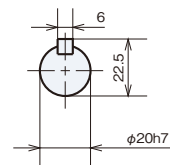

# Output Options

■ Bellows ( - J)

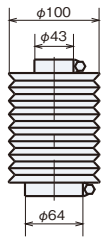

■ Rod Type End Fitting ( - B)

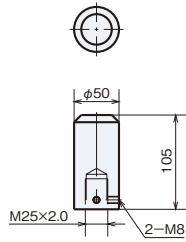

■ I Type End Fitting ( - I)

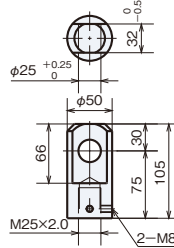

■ Table Type End Fitting ( - M)

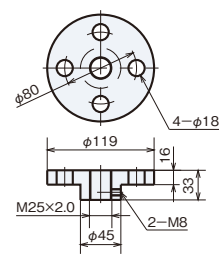

# JWB050 Dimensions - Travel Nut Type

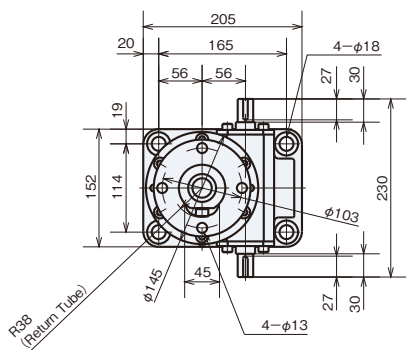

Stroke	UR Travel Nut Type for Lifting			DR Travel Nut Type for Suspending			Weight kg
	X		Y	X		Y	
	MIN	MAX		MIN	MAX		
100	157	257	369	145	245	257	21
200	157	357	469	145	345	357	22
300	157	457	569	145	445	457	22
400	157	557	669	145	545	557	23
500	157	657	769	145	645	657	24
600	157	757	869	145	745	757	24
800	157	957	1069	145	945	957	26
1000	157	1157	1269	145	1145	1157	27
1200	157	1357	1469	145	1345	1357	29
1500	157	1657	1769	145	1645	1657	31

**Lift (JWB050UR)**

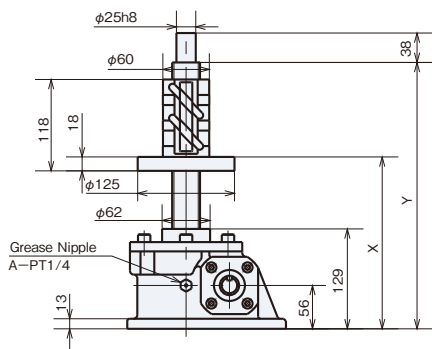

**Suspend (JWB050DR)**

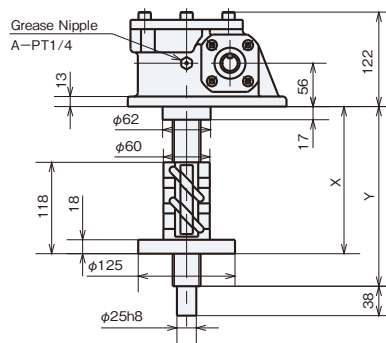

● **Input Shaft**

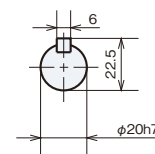

Note) Ball nut return tube and travel flange openings may vary from this drawing. Note the return tube measurements when installing to equipment.

Travel nut type cannot be equipped with optional end fitting (B.I.M). For types with bellows, refer to page 249.

\* For dimensions with no tolerances, general tolerances shall apply, and they may be approximately 2 – 5mm larger than the dimensions shown. For machine design, take margins into consideration.

## JWB100 Dimensions - Standard Model

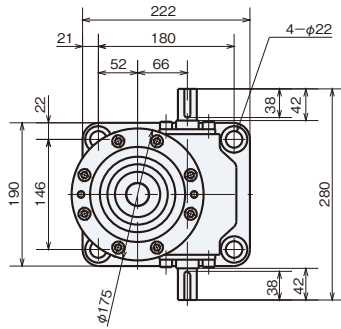

Stroke	US Standard Model for Lifting					DS Standard Model for Suspending					Weight kg
	X		X		L	X		X		L	
	Without Bellows	With Bellows	Without Bellows	With Bellows		Without Bellows	With Bellows	Without Bellows	With Bellows		
MIN	MAX	MIN	MAX		MIN	MAX	MIN	MAX			
100	302	402	312	412	151	42	142	52	152	151	36
200	302	502	312	512	252	42	242	52	252	252	38
300	302	602	327	627	366	42	342	67	367	366	41
400	302	702	327	727	466	42	442	67	467	466	43
500	302	802	352	852	591	42	542	92	592	591	46
600	302	902	352	952	691	42	642	92	692	691	48
800	302	1102	367	1167	906	42	842	107	907	906	53
1000	302	1302	377	1377	1116	42	1042	117	1117	1116	58
1200	302	1502	402	1602	1341	42	1242	142	1342	1341	63
1500	302	1802	427	1927	1666	42	1542	167	1667	1666	71

Lift (JWB100US)

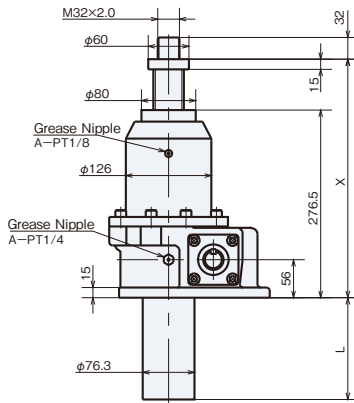

Suspend (JWB100DS)

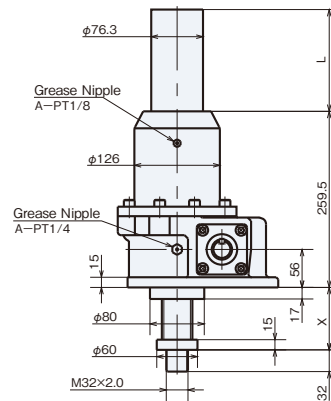

● Input Shaft

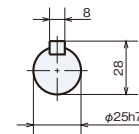

## JWB100 Dimensions - Rotation Prevention Type

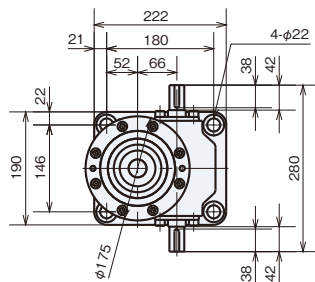

Stroke	UM Rotation Prevention Type for Lifting					DM Rotation Prevention Type for Suspending					Weight kg
	X		X		L	X		X		L	
	Without Bellows	With Bellows	Without Bellows	With Bellows		Without Bellows	With Bellows	Without Bellows	With Bellows		
MIN	MAX	MIN	MAX		MIN	MAX	MIN	MAX			
100	302	402	312	412	192	42	142	52	152	192	39
200	302	502	312	512	292	42	242	52	252	292	42
300	302	602	327	627	407	42	342	67	367	407	45
400	302	702	327	727	507	42	442	67	467	507	48
500	302	802	352	852	632	42	542	92	592	632	52
600	302	902	352	952	732	42	642	92	692	732	55
800	302	1102	367	1167	947	42	842	107	907	947	61
1000	302	1302	377	1377	1157	42	1042	117	1117	1157	67
1200	302	1502	402	1602	1382	42	1242	142	1342	1382	74
1500	302	1802	427	1927	1707	42	1542	167	1667	1707	84

Lift (JWB100UM)

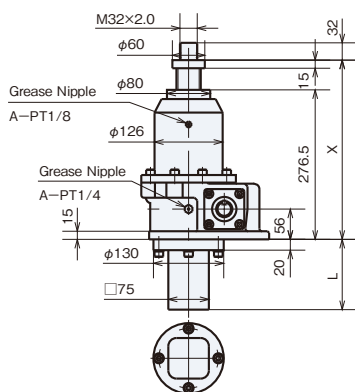

Suspend (JWB100DM)

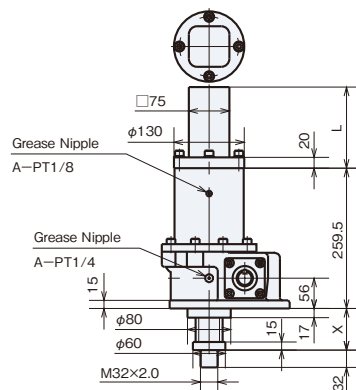

● Input Shaft

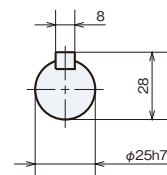

# Output Options

■ Bellows ( - J)

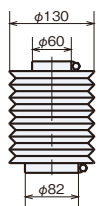

■ Rod Type End Fitting ( - B)

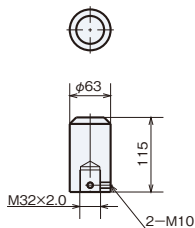

■ I Type End Fitting ( - I)

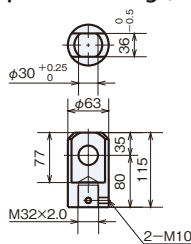

■ Table Type End Fitting ( - M)

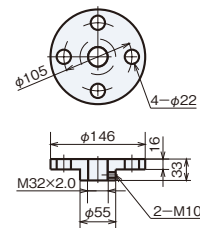

# JWB100 Dimensions - Travel Nut Type

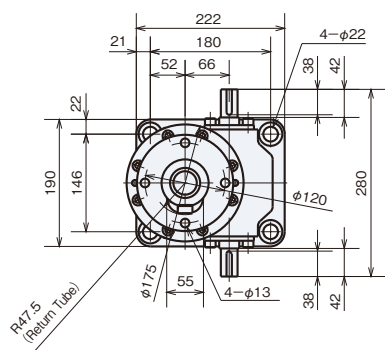

Stroke	UR Travel Nut Type for Lifting			DR Travel Nut Type for Suspending			Weight kg
	X		Y	X		Y	
	MIN	MAX		MIN	MAX		
100	184	284	414	185	285	295	31
200	184	384	514	185	385	395	32
300	184	484	614	185	485	495	33
400	184	584	714	185	585	595	34
500	184	684	814	185	685	695	35
600	184	784	914	185	785	795	36
800	184	984	1114	185	985	995	39
1000	184	1184	1314	185	1185	1195	41
1200	184	1384	1514	185	1385	1395	43
1500	184	1684	1814	185	1685	1695	46

Lift (JWB100UR)

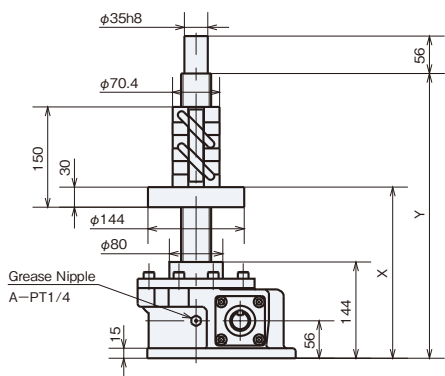

Suspend (JWB100DR)

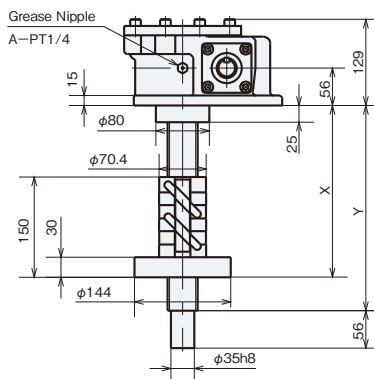

● Input Shaft

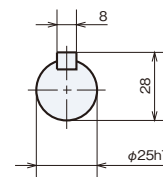

Note) Ball nut return tube and travel flange openings may vary from this drawing.  
Note the return tube measurements when installing to equipment.

Travel nut type cannot be equipped with optional end fitting (B.I.M).  
For types with bellows, refer to page 249.

\* For dimensions with no tolerances, general tolerances shall apply, and they may be approximately 2 – 5mm larger than the dimensions shown. For machine design, take margins into consideration.

## JWB150 Dimensions - Standard Model

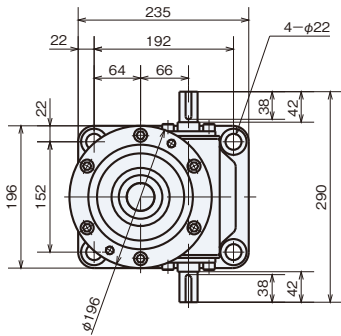

Stroke	US Standard Model for Lifting					DS Standard Model for Suspending					Weight kg
	X		X		L	X		X		L	
	Without Bellows	With Bellows	Without Bellows	With Bellows		Without Bellows	With Bellows	Without Bellows	With Bellows		
MIN	MAX	MIN	MAX		MIN	MAX	MIN	MAX			
100	342	442	352	452	151	42	142	52	152	151	46
200	342	542	352	552	252	42	242	52	252	252	48
300	342	642	367	667	366	42	342	67	367	366	51
400	342	742	367	767	466	42	442	67	467	466	54
500	342	842	392	892	591	42	542	92	592	591	57
600	342	942	392	992	691	42	642	92	692	691	60
800	342	1142	407	1207	906	42	842	107	907	906	65
1000	342	1342	417	1417	1116	42	1042	117	1117	1116	70
1200	342	1542	442	1642	1341	42	1242	142	1342	1341	76
1500	342	1842	467	1967	1666	42	1542	167	1667	1666	84

Lift (JWB150US)

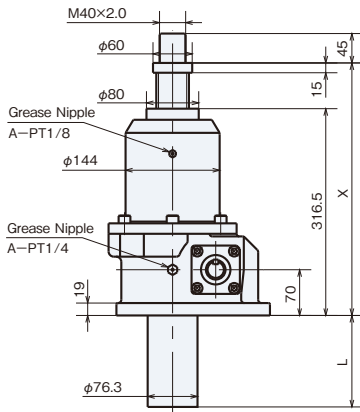

Suspend (JWB150DS)

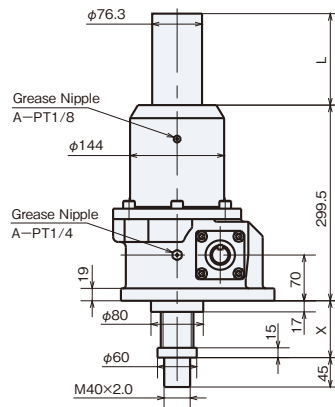

● Input Shaft

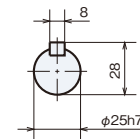

## JWB150 Dimensions - Rotation Prevention Type

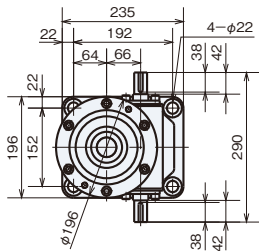

Stroke	UM Rotation Prevention Type for Lifting					DM Rotation Prevention Type for Suspending					Weight kg
	X		X		L	X		X		L	
	Without Bellows	With Bellows	Without Bellows	With Bellows		Without Bellows	With Bellows	Without Bellows	With Bellows		
MIN	MAX	MIN	MAX		MIN	MAX	MIN	MAX			
100	342	442	352	452	221	42	142	52	152	221	52
200	342	542	352	552	321	42	242	52	252	321	55
300	342	642	367	667	436	42	342	67	367	436	59
400	342	742	367	767	536	42	442	67	467	536	62
500	342	842	392	892	661	42	542	92	592	661	66
600	342	942	392	992	761	42	642	92	692	761	69
800	342	1142	407	1207	976	42	842	107	907	976	75
1000	342	1342	417	1417	1186	42	1042	117	1117	1186	82
1200	342	1542	442	1642	1411	42	1242	142	1342	1411	89
1500	342	1842	467	1967	1736	42	1542	167	1667	1736	99

Lift (JWB150UM)

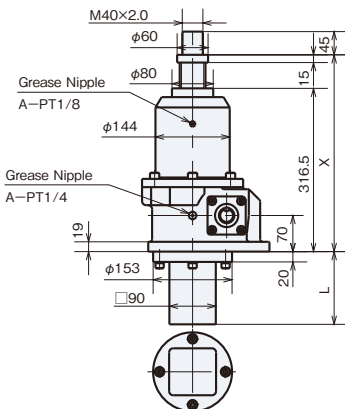

Suspend (JWB150DM)

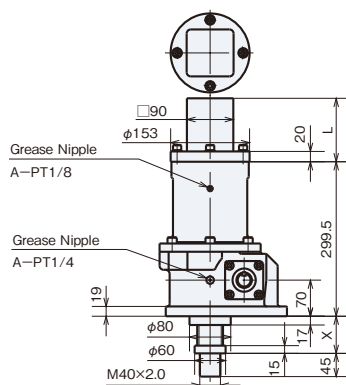

● Input Shaft

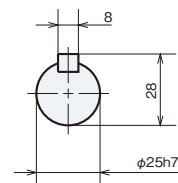

# Output Options

■ Bellows ( - J)



■ Rod Type End Fitting ( - B)

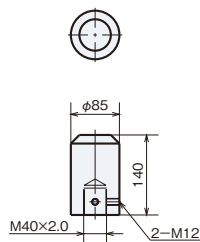

■ I Type End Fitting ( - I)

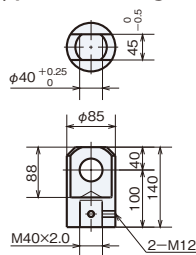

■ Table Type End Fitting ( - M)

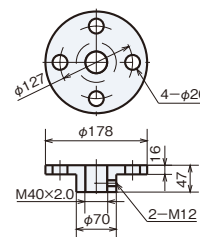

## JWB150 Dimensions - Travel Nut Type

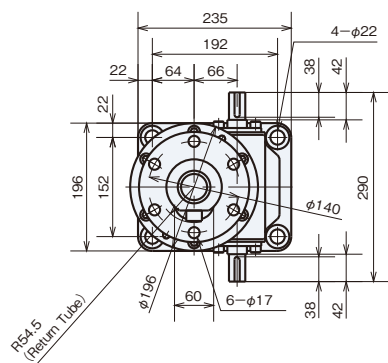

Stroke	UR Travel Nut Type for Lifting			DR Travel Nut Type for Suspending			Weight kg
	X		Y	X		Y	
	MIN	MAX		MIN	MAX		
100	214	314	448	197	297	308	41
200	214	414	548	197	397	408	42
300	214	514	648	197	497	508	43
400	214	614	748	197	597	608	45
500	214	714	848	197	697	708	46
600	214	814	948	197	797	808	47
800	214	1014	1148	197	997	1008	50
1000	214	1214	1348	197	1197	1208	53
1200	214	1414	1548	197	1397	1408	55
1500	214	1714	1848	197	1697	1708	59

Lift (JWB150UR)

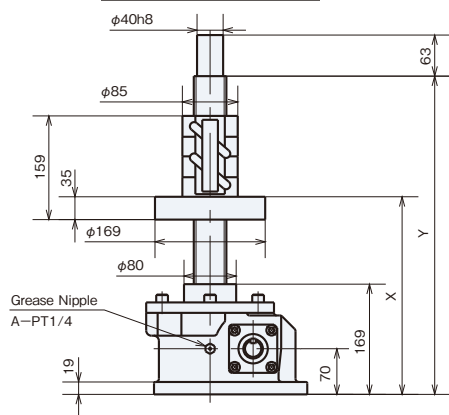

Suspend (JWB150DR)

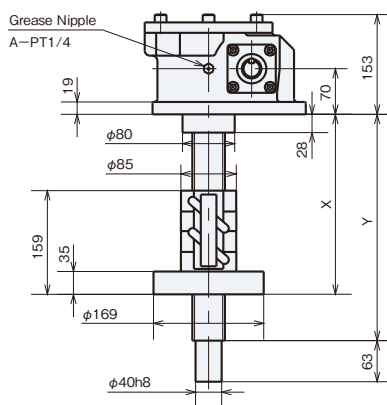

● Input Shaft

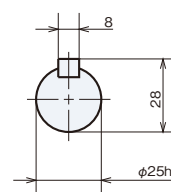

Note) Ball nut return tube and travel flange openings may vary from this drawing.  
Note the return tube measurements when installing to equipment.

Travel nut type cannot be equipped with optional end fitting (B.I.M).  
For types with bellows, refer to page 249.



## JWB200 Dimensions - Standard Model

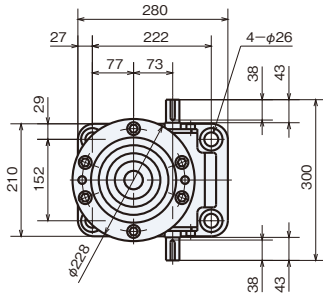

Stroke	US Standard Model for Lifting					DS Standard Model for Suspending					Weight kg
	X		X		L	X		X		L	
	Without Bellows	With Bellows	Without Bellows	With Bellows		Without Bellows	With Bellows	Without Bellows	With Bellows		
MIN	MAX	MIN	MAX		MIN	MAX	MIN	MAX			
100	406	506	416	516	136	42	142	52	152	136	65
200	406	606	416	616	236	42	242	52	252	236	68
300	406	706	431	731	351	42	342	67	367	351	72
400	406	806	431	831	451	42	442	67	467	451	76
500	406	906	456	956	576	42	542	92	592	576	80
600	406	1006	456	1056	676	42	642	92	692	676	83
800	406	1206	471	1271	891	42	842	107	907	891	90
1000	406	1406	481	1481	1101	42	1042	117	1117	1101	97
1200	406	1606	506	1706	1326	42	1242	142	1342	1326	105
1500	406	1906	531	2031	1651	42	1542	167	1667	1651	115
2000	406	2406	576	2576	2196	42	2042	212	2212	2196	133

Lift (JWB200US)

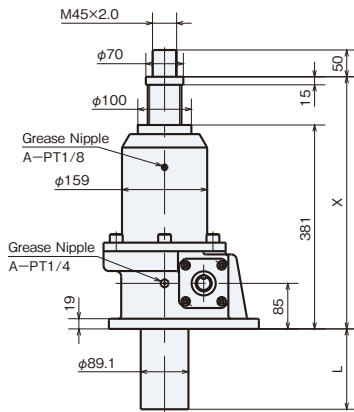

Suspend (JWB200DS)

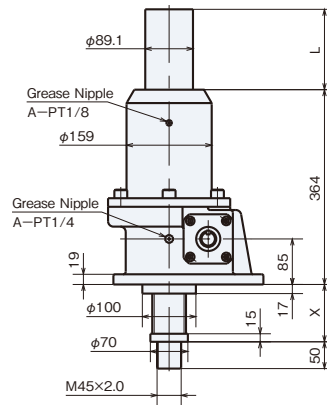

● Input Shaft

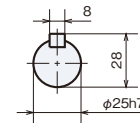

## JWB200 Dimensions - Rotation Prevention Type

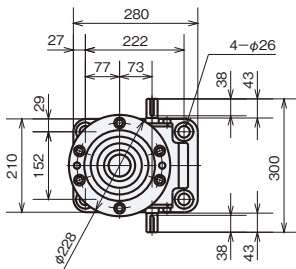

Stroke	UM Rotation Prevention Type for Lifting					DM Rotation Prevention Type for Suspending					Weight kg
	X		X		L	X		X		L	
	Without Bellows	With Bellows	Without Bellows	With Bellows		Without Bellows	With Bellows	Without Bellows	With Bellows		
MIN	MAX	MIN	MAX		MIN	MAX	MIN	MAX			
100	406	506	416	516	230	42	142	52	152	230	72
200	406	606	416	616	330	42	242	52	252	330	76
300	406	706	431	731	445	42	342	67	367	445	80
400	406	806	431	831	545	42	442	67	467	545	84
500	406	906	456	956	670	42	542	92	592	670	89
600	406	1006	456	1056	770	42	642	92	692	770	93
800	406	1206	471	1271	985	42	842	107	907	985	102
1000	406	1406	481	1481	1195	42	1042	117	1117	1195	110
1200	406	1606	506	1706	1420	42	1242	142	1342	1420	119
1500	406	1906	531	2031	1745	42	1542	167	1667	1745	131
2000	406	2406	576	2576	2290	42	2042	212	2212	2290	153

Lift (JWB200UM)

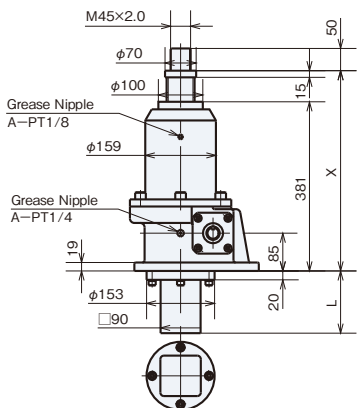

Suspend (JWB200DM)

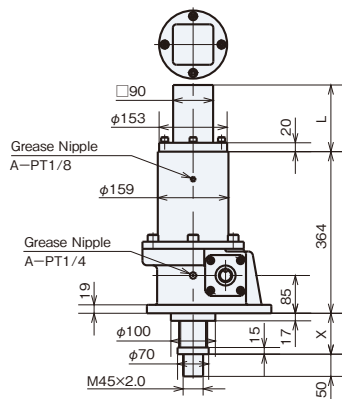

● Input Shaft

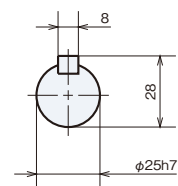

# Output Options

■ Bellows ( - J)



■ Rod Type End Fitting ( - B)

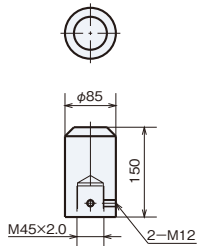

■ I Type End Fitting ( - I)

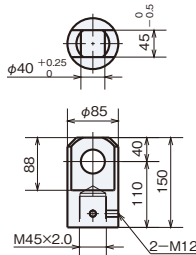

■ Table Type End Fitting ( - M)

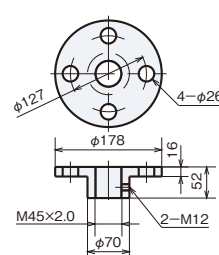

# JWB200 Dimensions - Travel Nut Type

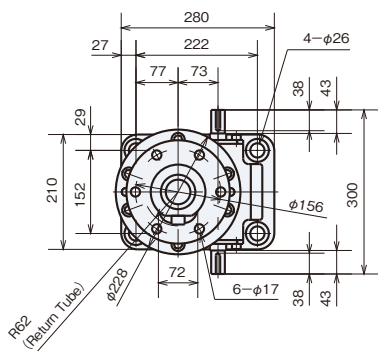

Stroke	UR Travel Nut Type for Lifting			DR Travel Nut Type for Suspending			Weight kg
	X		Y	X		Y	
	MIN	MAX		MIN	MAX		
100	237	337	503	232	332	342	56
200	237	437	603	232	432	442	58
300	237	537	703	232	532	542	60
400	237	637	803	232	632	642	62
500	237	737	903	232	732	742	65
600	237	837	1003	232	832	842	67
800	237	1037	1203	232	1032	1042	71
1000	237	1237	1403	232	1232	1242	76
1200	237	1437	1603	232	1432	1442	80
1500	237	1737	1903	232	1732	1742	86
2000	237	2237	2403	232	2232	2242	97

Lift (JWB200UR)

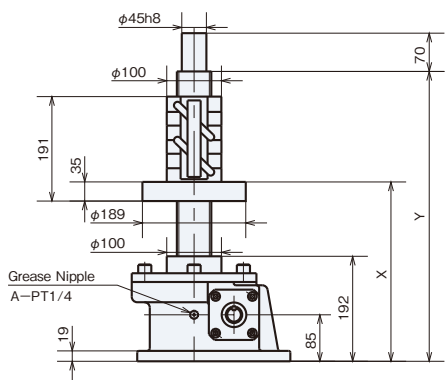

Suspend (JWB200DR)

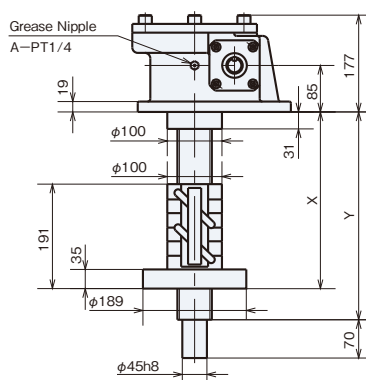

● Input Shaft

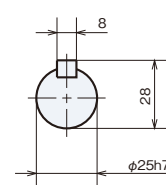

Note) Ball nut return tube and travel flange openings may vary from this drawing.  
Note the return tube measurements when installing to equipment.

Travel nut type cannot be equipped with optional end fitting (B.I.M).  
For types with bellows, refer to page 249.

\* For dimensions with no tolerances, general tolerances shall apply, and they may be approximately 2 – 5mm larger than the dimensions shown. For machine design, take margins into consideration.

# JWB300 Dimensions - Standard Model

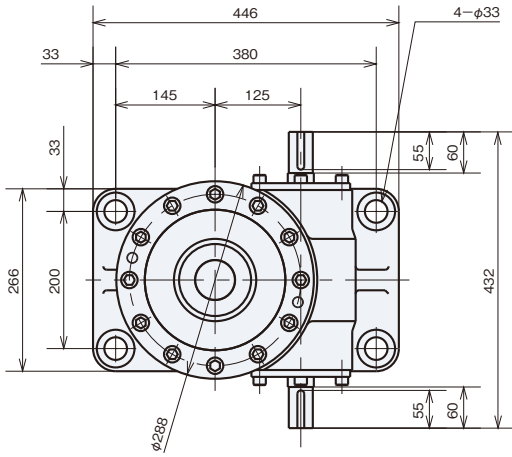

Stroke	US Standard Model for Lifting					DS Standard Model for Suspending					Weight kg
	X Without Bellows		X With Bellows		L	X Without Bellows		X With Bellows		L	
	MIN	MAX	MIN	MAX		MIN	MAX	MIN	MAX		
100	480	580	490	590	135	55	155	65	165	135	153
200	480	680	490	690	235	55	255	65	265	235	159
300	480	780	505	805	350	55	355	80	380	350	166
400	480	880	505	905	450	55	455	80	480	450	172
500	480	980	520	1020	565	55	555	95	595	565	178
600	480	1080	520	1120	665	55	655	95	695	665	184
800	480	1280	535	1335	880	55	855	110	910	880	197
1000	480	1480	555	1555	1100	55	1050	130	1130	1100	210
1200	480	1680	565	1765	1310	55	1255	140	1340	1310	223
1500	480	1980	590	2090	1635	55	1555	165	1665	1635	242
2000	480	2480	625	2625	2170	55	2055	200	2200	2170	274

### Input Shaft

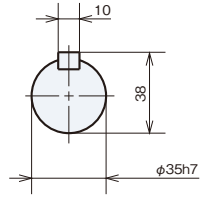

### Lift (JWB300US)

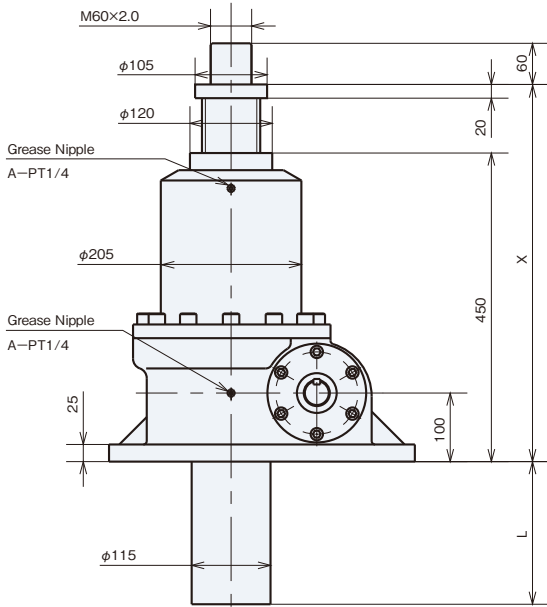

### Suspend (JWB300DS)

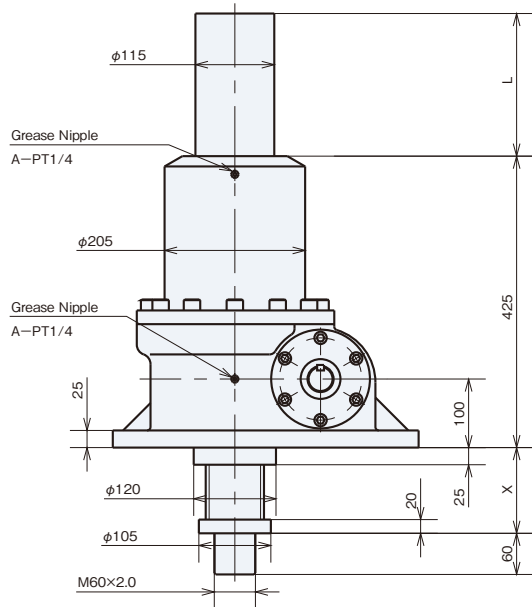

For JWBC300 (compact type), see page 257 - 260.

## Output Options

### ■ Bellows ( - J)

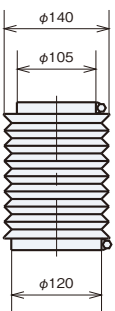

### ■ Rod Type End Fitting ( - B)

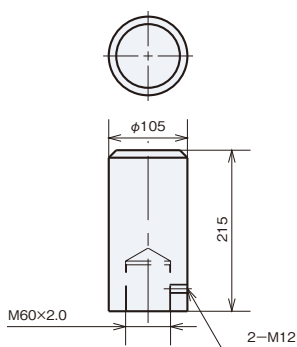

### ■ I Type End Fitting ( - I)

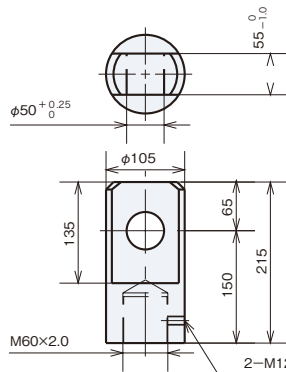

### ■ Table Type End Fitting ( - M)

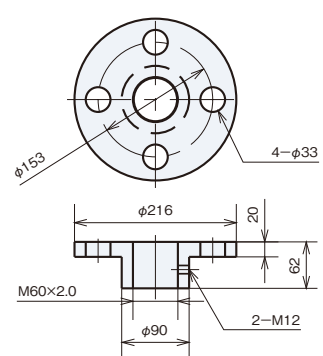

## JWB500 Dimensions - Standard Model

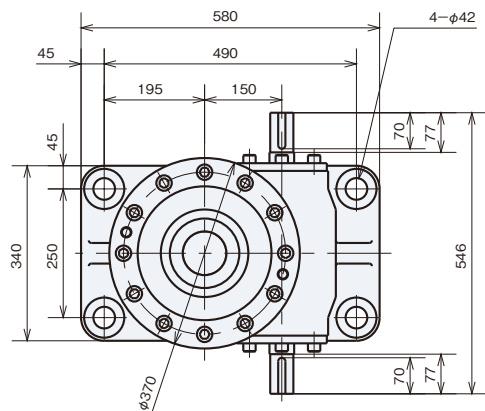

Stroke	US Standard Model for Lifting					DS Standard Model for Suspending					Weight kg
	X		X		L	X		X		L	
	Without Bellows	With Bellows	Without Bellows	With Bellows		Without Bellows	With Bellows	Without Bellows	With Bellows		
MIN	MAX	MIN	MAX		MIN	MAX	MIN	MAX			
100	580	680	585	685	137	55	155	60	160	137	310
200	580	780	585	785	237	55	255	60	260	237	320
300	580	880	605	905	357	55	355	80	380	357	330
400	580	980	605	1005	457	55	455	80	480	457	340
500	580	1080	615	1115	567	55	555	90	590	567	350
600	580	1180	615	1215	667	55	655	90	690	667	359
800	580	1380	630	1430	882	55	855	105	905	882	378
1000	580	1580	645	1645	1097	55	1055	120	1120	1097	398
1200	580	1780	655	1855	1307	55	1255	130	1330	1307	417
1500	580	2080	675	2175	1627	55	1555	150	1650	1627	446
2000	580	2580	710	2710	2162	55	2055	185	2185	2162	495

● Input Shaft

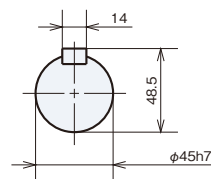

Lift (JWB500US)

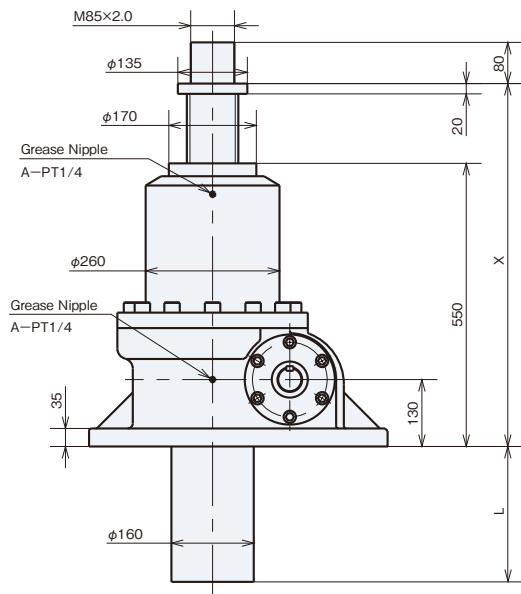

Suspend (JWB500DS)

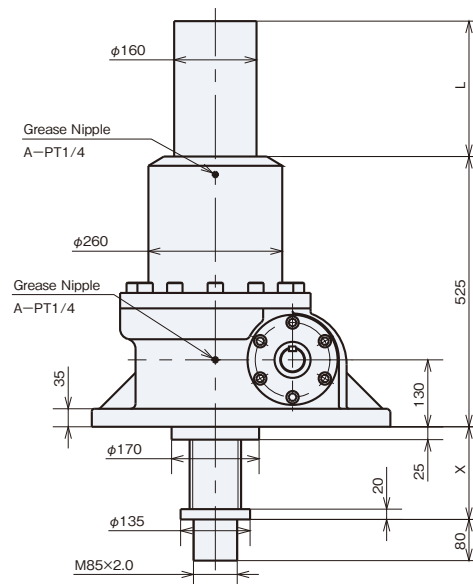

For JWBC500 (compact type), see page 257 - 260.

## Output Options

■ Bellows ( - J)

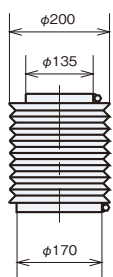

■ Rod Type End Fitting ( - B)

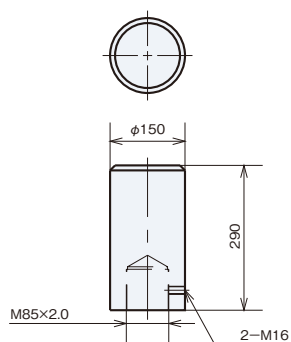

■ I Type End Fitting ( - I)

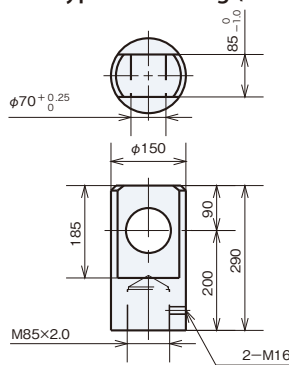

■ Table Type End Fitting ( - M)

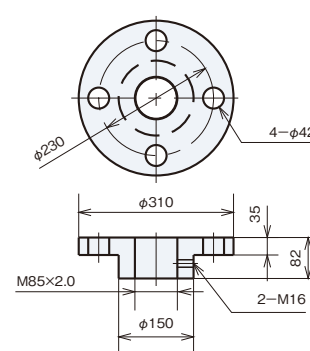

\* For dimensions with no tolerances, general tolerances shall apply, and they may be approximately 2 - 5mm larger than the dimensions shown. For machine design, take margins into consideration.



# Warning

## ■ Cautions for selecting

- Duty cycle of JWB (Ball Screw Type) is within 30% ED. Duty cycle is a ratio of operating time per 30 min on the basis of 30 min interval.
- JWB (Ball Screw Type) does not have a self-locking device, therefore, a brake mechanism is required.
- Activating torque for the drive unit should be maintained at 200% above the required torque.
- Allowable input rotation speed of linear power jack is 1800 r/min, however, when inputting a speed exceeding the maximum input rotation speed at the basic capacity, check the screw shaft speed (elevation speed) and allowable load related graphs on page 155.
- Select a stroke for the jack with an extra margin with respect to the used stroke.
- Rotating force is generated on the screw shaft (travel nut in the case of travel nut type) with thrust, therefore, rotation prevention is required. Screw rotation torque at the basic capacity is described in the standard specification list. When operating with the end unconnected, and pulling the rope with a sheave installed, use the rotation prevention type. However, the rotation prevention type cannot be manufactured for the travel nut type, therefore, provide a rotation prevention mechanism on the device.
- When installing a sprocket, gear, or belt to the input or output shaft, confirm that any overhang load applied to the shaft decreases to the allowable OHL or less.

$$\text{Allowable O. H. L.} \geq \frac{T \times f \times L_f}{R}$$

O.H.L. : Overhang load N {kgf}  
 T : Input torque N · m {kgf · m}  
 f : Coefficient - power transmission element  
 L<sub>f</sub> : Coefficient - Load operating position  
 R : Sprocket, Gear, V pulley or Pitch diameter m

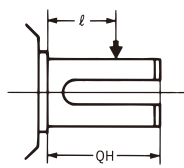

Q : Shaft Length  
 ℓ : Loaded Position

### ● Coefficient – Power Transmission Element (f)

Sprocket	1.00
Gear	1.25
V-belt	1.50
Flat belt	2.50

### ● Coefficient (L<sub>f</sub>) – Load Position

ℓ / QH	0.25	0.38	0.5	0.75	1
L <sub>f</sub>	0.8	0.9	1	1.5	2

### ● Allowable O.H.L

Frame No.		002	005	010	025	050	100	150	200	300	500	750	1000
JWB (Ball Screw Type)	N	—	130	220	480	870	1290	2030	2490	3450	5240	7200	9790
H Speed	{ kgf }	—	{14}	{23}	{50}	{89}	{132}	{208}	{255}	{352}	{535}	{735}	{998}
JWB (Ball Screw Type)	N	—	82	140	290	500	840	1300	1610	2400	3560	4940	6970
L Speed	{ kgf }	—	{8}	{15}	{31}	{52}	{86}	{133}	{165}	{245}	{363}	{504}	{711}

## ■ Precautions for installation

- Some screw covers of jacks are made of hard vinyl chloride pipe. Do not lift jack and transport with this pipe, which may result in dropping.
- JWB (Ball Screw Type) rotates by self weight of the screw shaft or travel nut, therefore, retract its stroke to the minimum and provide a rotation prevention for installation.
- Take jack coasting amount into consideration to set the stroke adjusting limit switch.

## ■ Precautions for use

- Do not perform manual operation from the input shaft with load applied. The input shaft is rotated by the load, which is dangerous.
- When JWB (Ball Screw Type) is used in the vertical direction, the jack may be reversed by the load because of its excellent efficiency. Never perform manual operation.
- Do not use mechanical stops under any circumstances.
- Operating Environment for jack is as follows.

Operating place	Indoor room which cannot be splashed with rain or water.
Ambient atmosphere	Dust volume comparable to general factories.
Operating temperature range	− 15 to 80°C (Refer to section 3 in general precautions.)
Relative humidity	85% or less (no dew condensation)

- Operating part and reducer unit are factory greased. Therefore, use jack as delivered.
- For lubrication grease, lubrication cycle and lubrication amount to the screw shaft and reducer unit, refer to page 253.
- Inspect regularly for general backlash and screw unit condition. Jack life and replacement timing are determined by the following:  
 Metal particles due to wear on the screw surface are visible.  
 Replace gear when its input shaft exceeds 30 rpm with backlash (rattle between input shaft and worm wheel) at H speed, or exceeds 60 rpm at L speed.  
 In either case, if it is used at the replacement timing, this may cause rotation failure of screw shaft and input shaft, and further sudden drop of travel nut.

Linipower Jack

# JWH (High Lead Ball Screw Type)

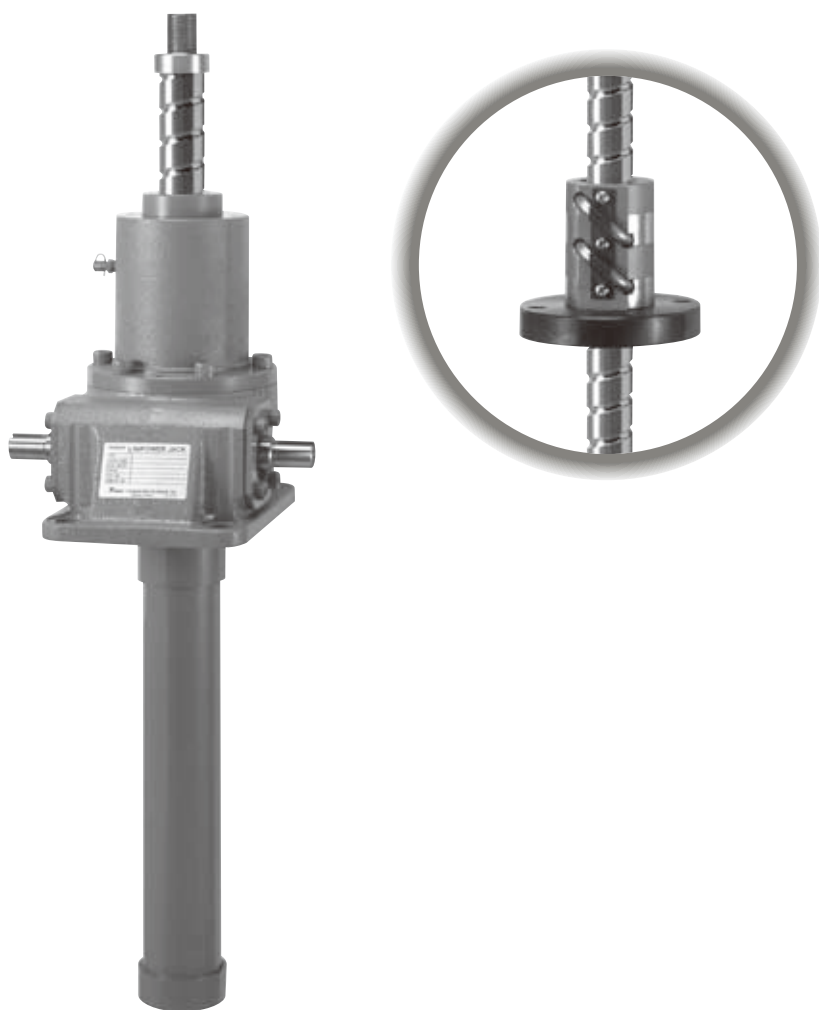

Drawings	—————	P215•216
JWH Reference Number System	—————	P217•218
Reference Table for Standard Use	—————	P219•220
Dimensions	—————	P221~226
Precautions	—————	P227

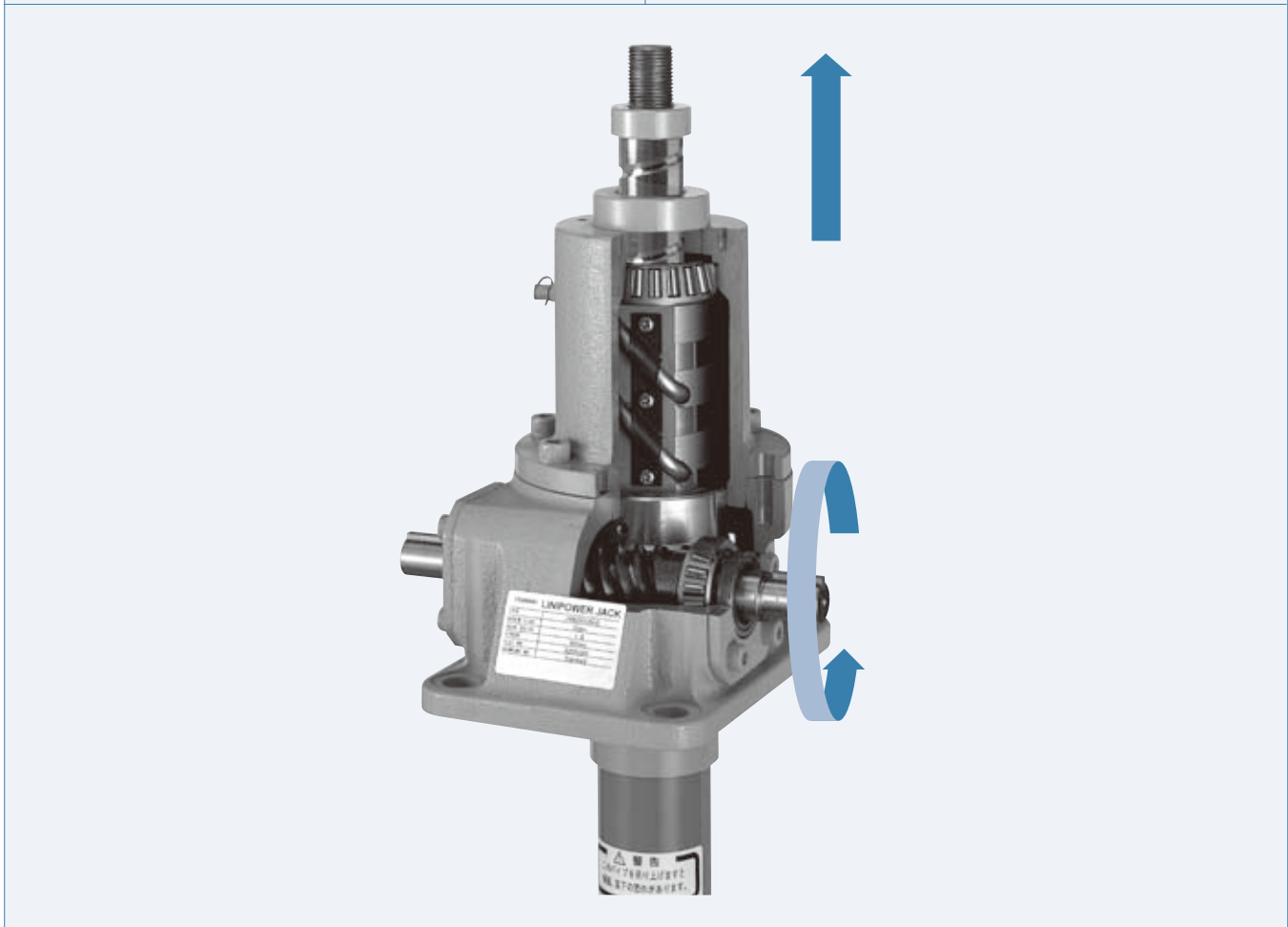
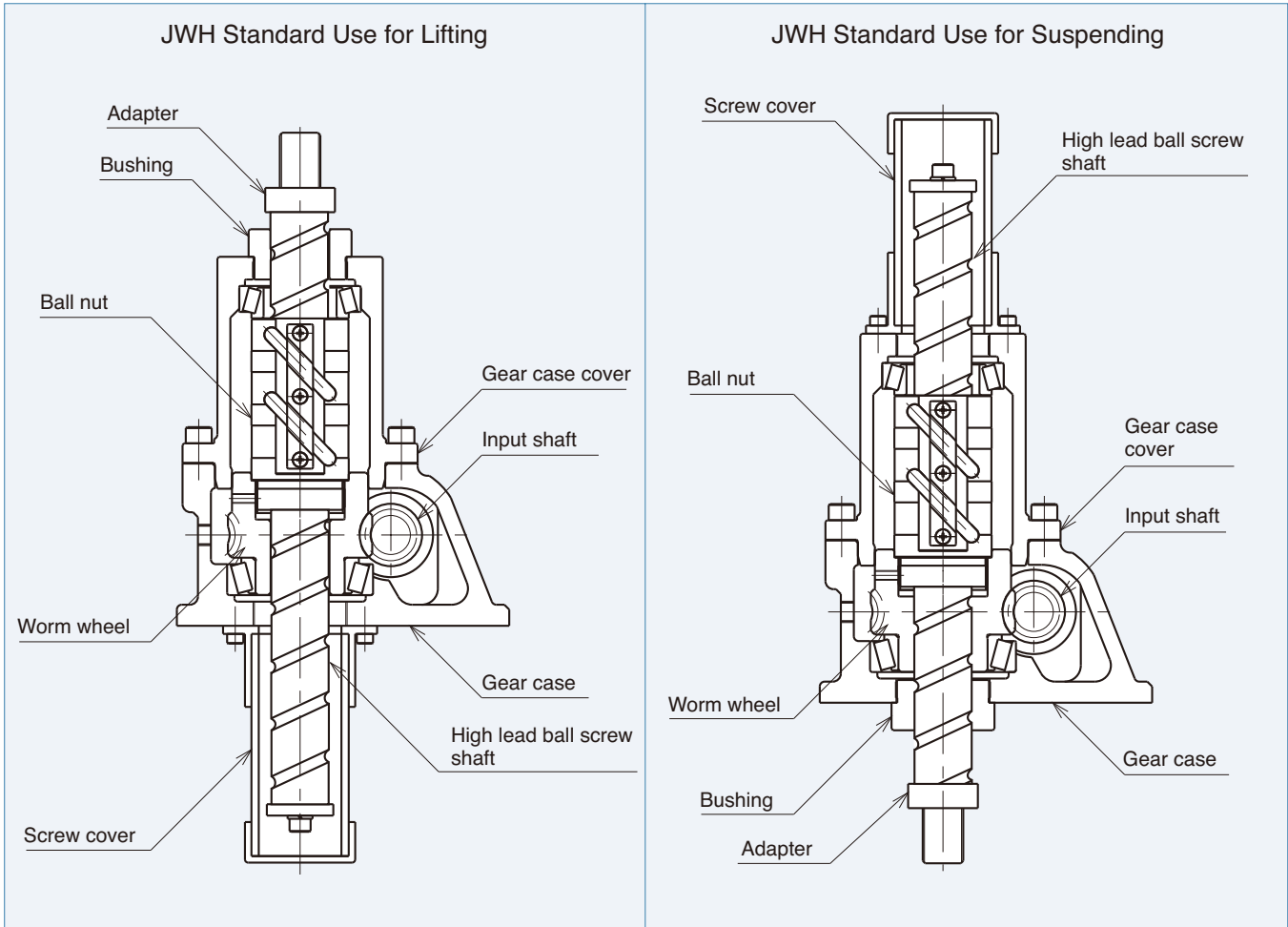



JWH (High Lead Ball Screw Type) Rotation Prevention Type

JWH010~200

(With Rotation Prevention and Guide Nut)

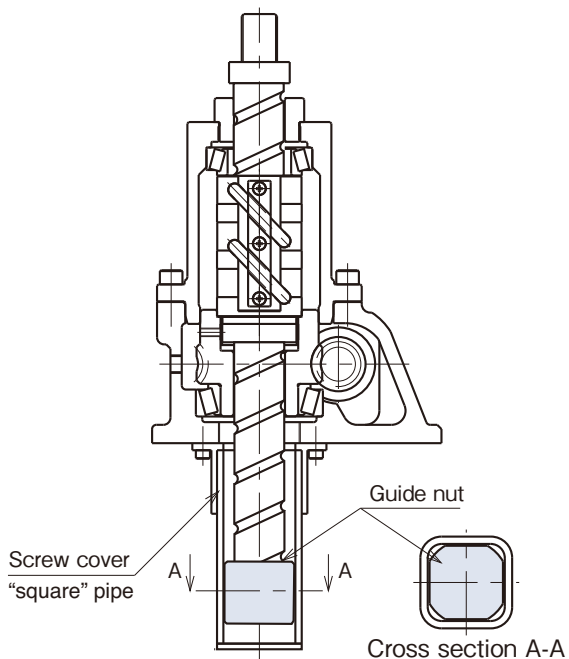

Note) The 10°space in each corner between the guide and the pipe allows smooth rotation.

Caution

Each High Lead Ball Screw Jack with rotation prevention is made-to-order based. Inform TSUBAKI E&M of operating conditions such as a load per one jack and screw shaft speed of the jack. We will take the conditions into account.

JWH (High Lead Ball Screw Type) Travel Nut Type

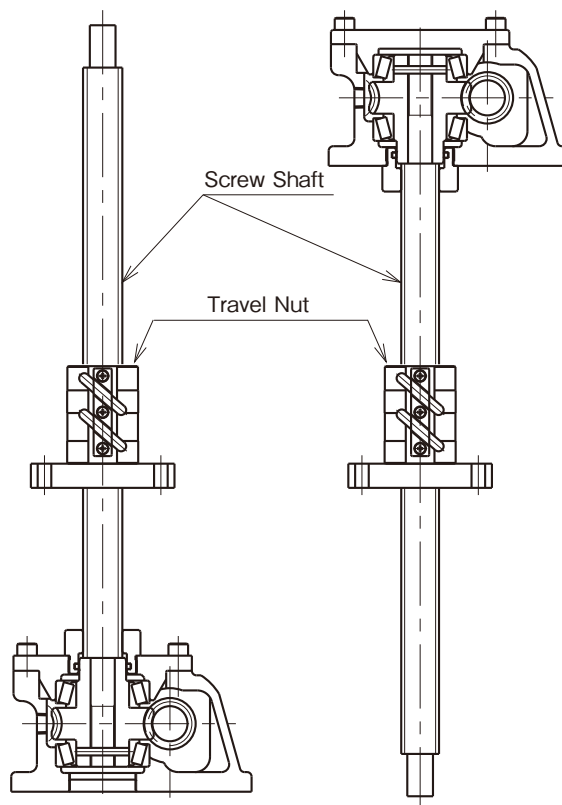

# JWH (High Lead Ball Screw Type)

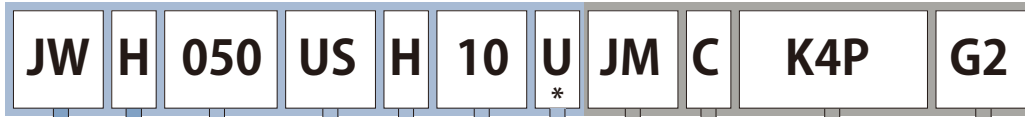

Linipower Jack

Jack Type

H : High Lead Ball Screw

Basic Capacity

Frame No.	kN	{tf}
010	9.80	{1}
025	24.5	{2.5}
050	49.0	{5}
100	98.0	{10}
150	147	{15}
200	196	{20}

Installation Type

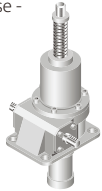
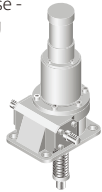
US	Standard Use - Lifting	
DS	Standard Use - Suspending	

\* Rotation prevention for JWH are available upon request. To request, provide TSUBAKI E&M with information on your operation conditions.

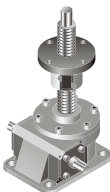
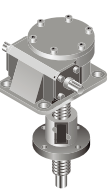
UR	Travel Nut - Lifting	
DR	Travel Nut - Suspending	

\* Be sure to use the flange installation method U or D with travel nuts.

Stroke mm

1	100
3	300
6	600
10	1000

\*The above values are examples. For actual stroke used, refer to the Model Comparison Table for JWH on page 145.

Gear Ratio

symbol Frame No.	H
010	5
025	6
050	6
100	8
150	8
200	8

Flange Installation

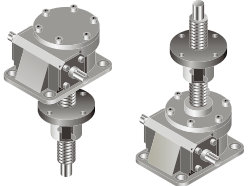
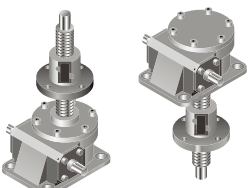
U	
D	

\* Above are only necessary with travel nuts.

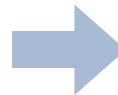

Examples)





**JWH100UMH3**

- High Lead Ball Screw Type • 98.0kN {10tf} • Standard use (for lifting) • Gear ratio H (1/8) • Stroke 300mm

**JWH050USH10JMK4P**

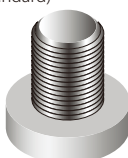
- High Lead Ball Screw Type • 49.0kN {5tf} • Standard use (for lifting) • Gear ratio H (1/6) • Stroke 1000mm
- Bellows / Table Type End Fitting • 4 Internal LS / Potentiometer

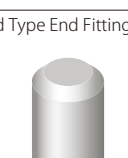
Output Option

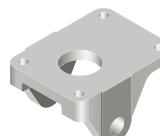

<b>No symbol</b>	Screw shaft end (standard) 
<b>J</b>	Bellows 
<b>B</b>	Rod Type End Fitting 
<b>I</b>	I Type End Fitting 
<b>M</b>	Table Type End Fitting 

Installation Option

<b>C</b>	Clevis Mounting Adapter  (See page 245)
----------	---



Note) For standard lifting only.

Sensor Option

<b>Y</b>	LS Counter  (See page 239)
<b>K2</b> <b>K4</b> <b>P</b> <b>R</b>	Position Sensor K2...2 Internal LS K4...4 Internal LS P...Potentiometer R...Rotary Encoder  (See page 241)

Note) To request the above parts, provide their letter symbols in the order given.

Input Option

<b>E</b> <b>EV</b>	3 phase brake and motor E...200V 50Hz 200/220V 60Hz EV...400 50Hz 400/440V 60Hz  (Page 229~)
<b>G1</b> <b>G2</b>	3 phase brake and gear-motor G1...Gear ratio 1/5 200V 50Hz 200/220V 60Hz G2...Reducer ratio 1/10 200V 50Hz 200/220V 60Hz  (Page 229~)

Accessories

<b>Control Options</b>
Stroke Meter and PCB 
Meter Relay and PCB  (Page 242~)
<b>Others</b>
Trunnion Mounting Adapter  *Use as a set with clevis mounting adapter. (See page 245)

Note) To request the above parts, provide their letter symbols in the order given. When travel nuts are used, B, I and M are not required.

Note) Bellows is of special specification, therefore contact TSUBAKI E&M.

Note) Travel nut type with bellows is estimated for each order. Enter necessary information in the inquiry form on page 249 to contact TSUBAKI E&M.

## Reference Table for Standard Use JWH (High Lead Ball Screw Type)

Frame No.		JWH010	JWH025	JWH050
Basic Capacity	kN	9.80	24.5	49.0
	{tf}	{1}	{2.5}	{5}
Outer Screw Diameter	mm	20	25	36
Minor Screw Diameter	mm	17.5	21.9	31.1
Screw Lead	mm	20	25	25
Gear Ratio		5	6	6
Overall Efficiency	%	63	65	68
Max. Allowable Input Capacity	kW	0.75	1.5	2.3
Tare Drag Torque	N•m	0.29	0.62	1.37
	{kgf•m}	{0.03}	{0.063}	{0.14}
Holding Torque	N•m	5.22	13.6	27.5
	{kgf•m}	{0.53}	{1.4}	{2.8}
Allowable Input Torque	*Note 1 N•m	19.6	49.0	153.9
	{kgf•m}	{2}	{5}	{15.7}
Required Input Torque for Basic Capacity	N•m	10.2	25.6	49.2
	*Note 2 {kgf•m}	{1.0}	{2.6}	{5.0}
Screw Movement/ Per Revolution of Input Shaft	mm	4	4.17	4.17
Max. Input R.P.M.	r/min	1800	1800	1800
Max. Input R.P.M. for Basic Capacity	r/min	700	550	450
Screw Shaft Rotational Torque for Basic Capacity	N•m	33.2	103.8	207.6
	{kgf•m}	{3.4}	{10.6}	{21.2}
Screw Cover Material	Hard Vinyl Chloride			
Lubrication	Shaft: Grease Reducer Unit: Grease Bath			
Color	Tsubaki Olive Grey (Munsell 5GY6/0.5)			
Environment	Operating Temperature Range	- 15 to 80°C (Precautions #2)		
	Relative Humidity	85% or less (no dew condensation)		
	Operating ambient atmosphere	Indoor Environment (Indoor room where rain and water cannot enter. Dust volume should be normal.)		
Duty Cycle	*Note 3	Within 30% ED		

Note 1) The allowable torque is for jack input shaft only. (Reconfirm if synchronous drive.)

Note 2) Includes tare drag torque.

Note 3) Standard percentage duty cycle is 30 minutes. Thus, driving time is based on 30 minute intervals.

### Precautions

- All loads (static, dynamic or shock) should be within the rated capacity of the jack at sufficient safety levels.
- Operating Temperature Range refers to the surface temperature of the jack during operation. To check, measure the surface temperature of the input shaft unit or travel nut (if used). Be sure all the rotating parts have completely stopped before proceeding to measure.
- Allowable input rpm is 1800r/min. Be sure to operate within this allowable capacity.
- Number of synchronizing jacks which can be connected on

- the same line is limited by shaft strength. Refer to the allowable input shaft torque on the above table.
- Activating torque for the drive unit should be maintained at 200% above the required torque.
- If operating in freezing temperatures, a change in viscosity may reduce the efficiency of the grease. Set the drive unit so as to accommodate this change.
- Since JWH (High Lead Ball Screw Type) is extremely efficient, sufficient brake that over powers the "holding torque" is required to sustain its shaft.

JWH100	JWH150	JWH200
98.0 {10}	147 {15}	196 {20}
45	50	63
38.9	42.7	55.7
32	32	32
8	8	8
65	65	64
4.1	4.1	5.6
1.96 {0.2}	2.65 {0.27}	3.92 {0.4}
52.8 {5.4}	79.2 {8.1}	105.6 {10.8}
292.0 {29.8}	292.0 {29.8}	292.0 {29.8}
98.0 {10.0}	146.8 {15.0}	199.1 {20.3}
4	4	4
1800	1800	1800
400	270	270
531.5 {54.2}	797.3 {81.3}	1063.0 {108.4}
Steel Pipe		
Screw: Grease Reducer Unit: Grease Bath		
Tsubaki Olive Grey (Munsell 5GY6/0.5)		
- 15 to 80°C (Precautions #2)		
85% or less (no dew condensation)		
Indoor Environment (Indoor room where rain and water cannot enter. Dust volume should be normal.)		
Within 30% ED		

⚠8. Be certain that the jack rating exceeds the maximum stroke. Over travel can cause the lift shaft to disengage from the ball nut.  
JWH (High Lead Ball Screw Type) is supported by a stopper (shaft end). However, this is merely for the purpose of securing the screw shaft during installation. While installing, take caution so that the screw shaft does not rotate by its own weight and become disengaged. If rotation cannot be avoided, use a model with rotation prevention. (Contact TEM for details.)

⚠9. Do not use mechanical stops under any circumstances. This will cause major internal damage.  
10. Input shaft key is provided with each unit. (The input shaft key complies with JIS B 1301-1996 (normal grade).)

## JWH010 Dimensions - Standard Model

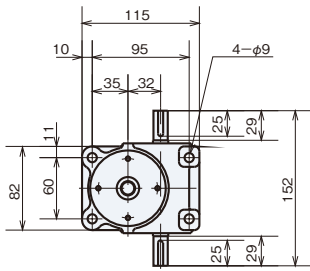

● Input Shaft

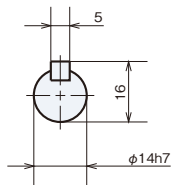

Stroke	US Standard Model for Lifting					DS Standard Model for Suspending					Weight kg
	X		X		L	X		X		L	
	Without Bellows	With Bellows	Without Bellows	With Bellows		Without Bellows	With Bellows	Without Bellows	With Bellows		
MIN	MAX	MIN	MAX		MIN	MAX	MIN	MAX			
100	162	262	212	312	194	25	125	75	175	194	6.7
200	162	362	212	412	294	25	225	75	275	294	7.0
300	162	462	252	552	434	25	325	115	415	434	7.4
400	162	562	252	652	534	25	425	115	515	534	7.6
500	162	662	287	787	669	25	525	150	650	669	8.0
600	162	762	287	887	769	25	625	150	750	769	8.2
800	162	962	322	1122	1004	25	825	185	985	1004	8.9
1000	162	1162	352	1352	1234	25	1025	215	1215	1234	9.5

Lift (JWH010US)

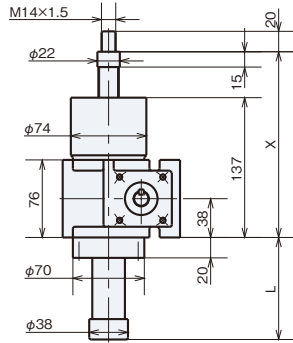

Suspend (JWH010DS)

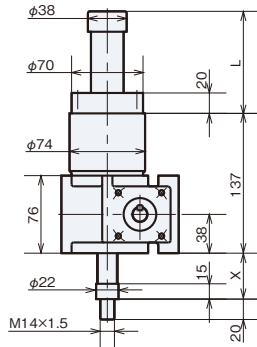

## Output Option

■ Bellows ( - J)

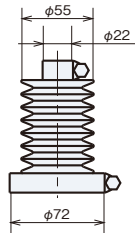

■ Rod Type End Fitting ( - B)

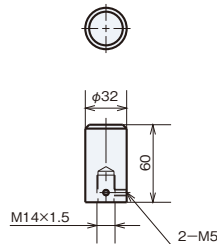

■ I Type End Fitting ( - I)

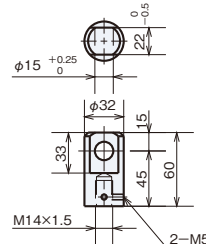

■ Table Type End Fitting ( - M)

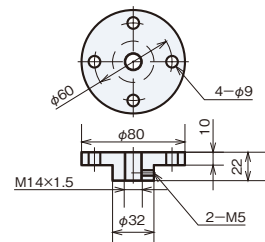

Note) For detailed measurements on units with bellows, see page 248.

## JWH010 Dimensions - Travel Nut Type

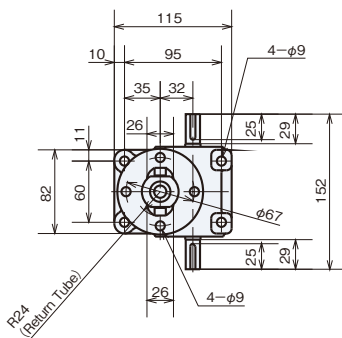

● Input Shaft

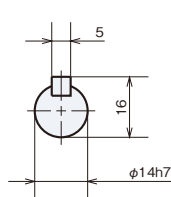

Stroke	UR Travel Nut Type for Lifting			DR Travel Nut Type for Suspending			Weight kg
	X		Y	X		Y	
	MIN	MAX		MIN	MAX		
100	108	208	265	69	169	179	5.9
200	108	308	365	69	269	279	6.1
300	108	408	465	69	369	379	6.4
400	108	508	565	69	469	479	6.6
500	108	608	665	69	569	579	6.8
600	108	708	765	69	669	679	7.0
800	108	908	965	69	869	879	7.4
1000	108	1108	1165	69	1069	1079	7.9

Lift (JWH010UR)

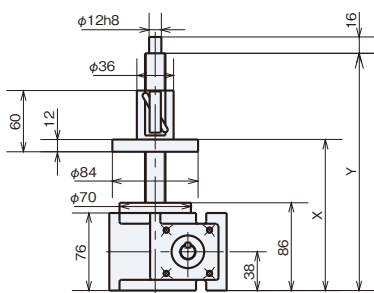

Suspend (JWH010DR)

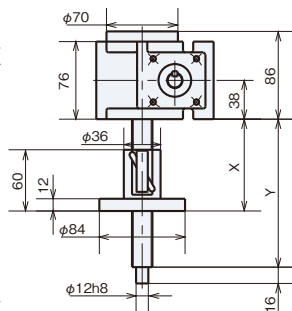

Note) Ball nut return tube and travel flange openings may vary from this drawing. Note the return tube measurements when installing to equipment.

Travel nut type cannot be equipped with optional end fitting (B.I.M). For types with bellows, refer to page 249.

\* For dimensions with no tolerances, general tolerances shall apply, and they may be approximately 2 - 5mm larger than the dimensions shown. For machine design, take margins into consideration.

## JWH025 Dimensions - Standard Model

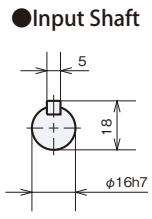
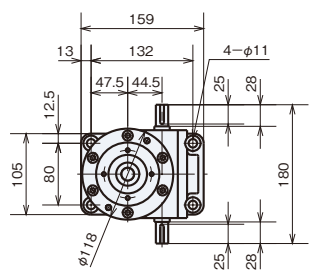

Stroke	US Standard Model for Lifting					DS Standard Model for Suspending					Weight kg
	X		X		L	X		X		L	
	Without Bellows	With Bellows	Without Bellows	With Bellows		Without Bellows	With Bellows	Without Bellows	With Bellows		
MIN	MAX	MIN	MAX		MIN	MAX	MIN	MAX			
100	215	315	230	330	149	42	142	57	157	149	11
200	215	415	230	430	249	42	242	57	257	249	11
300	215	515	250	550	369	42	342	77	377	369	11
400	215	615	250	650	469	42	442	77	477	469	12
500	215	715	270	770	589	42	542	97	597	589	12
600	215	815	270	870	689	42	642	97	697	689	13
800	215	1015	290	1090	909	42	842	117	917	909	14
1000	215	1215	310	1310	1129	42	1042	137	1137	1129	14
1200	215	1415	325	1525	1344	42	1242	152	1352	1344	15

**Lift (JWH025US)**

**Suspend (JWH025DS)**

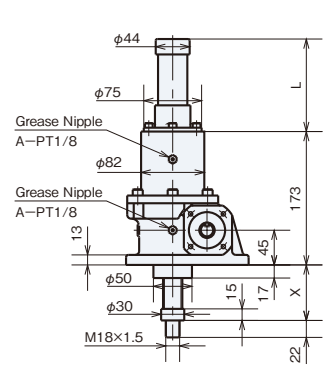
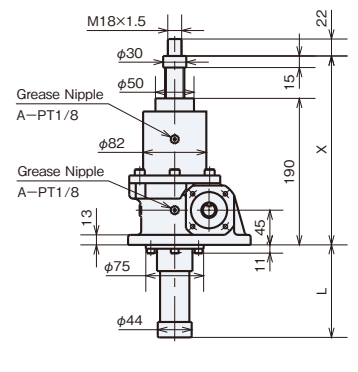

## Output Option

■ Bellows ( - J )

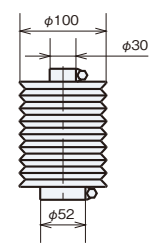

■ Rod Type End Fitting ( - B )

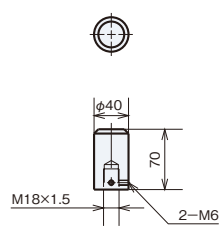

■ I Type End Fitting ( - I )

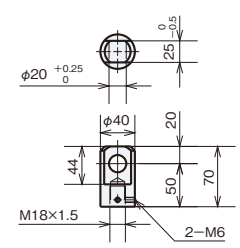

■ Table Type End Fitting ( - M )

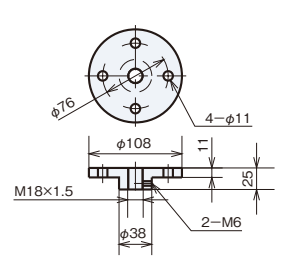

## JWH025 Dimensions - Travel Nut Type

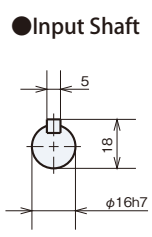
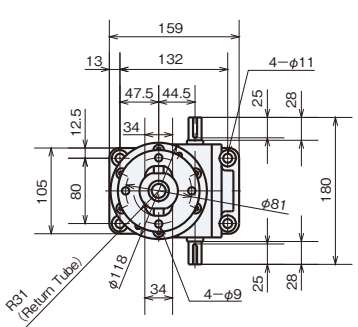

Stroke	UR Travel Nut Type for Lifting			DR Travel Nut Type for Suspending			Weight kg
	X		Y	X		Y	
	MIN	MAX		MIN	MAX		
100	133	233	309	108	208	219	9.2
200	133	333	409	108	308	319	9.5
300	133	433	509	108	408	419	9.8
400	133	533	609	108	508	519	11
500	133	633	709	108	608	619	11
600	133	733	809	108	708	719	11
800	133	933	1009	108	908	919	12
1000	133	1133	1209	108	1108	1119	13
1200	133	1333	1409	108	1308	1319	13

**Lift (JWH025UR)**

**Suspend (JWH025DR)**

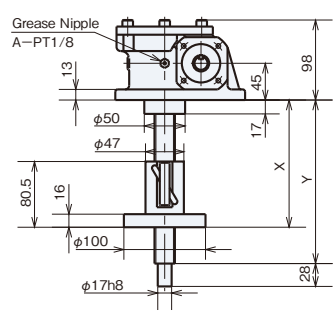
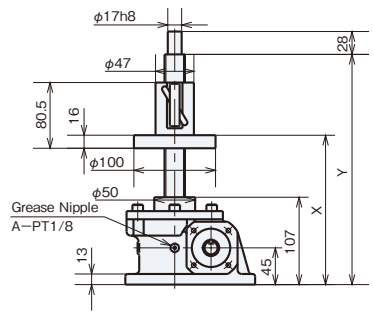

Note) Ball nut return tube and travel flange openings may vary from this drawing. Note the return tube measurements when installing to equipment.

Travel nut type cannot be equipped with optional end fitting (B.I.M). For types with bellows, refer to page 249.  
 \* For dimensions with no tolerances, general tolerances shall apply, and they may be approximately 2 - 5mm larger than the dimensions shown. For machine design, take margins into consideration.



## JWH050 Dimensions - Standard Model

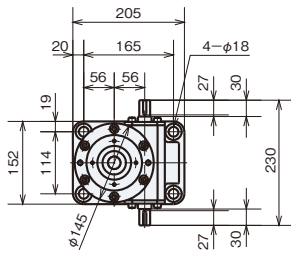

Lift (JWH050US)

### ● Input Shaft

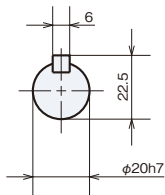

Suspend (JWH050DS)

Stroke	US Standard Model for Lifting				DS Standard Model for Suspending				Weight kg		
	X		X		X		X				
	Without Bellows	With Bellows	L	L	Without Bellows	With Bellows	L	L			
100	269	369	284	384	147	42	142	57	157	147	23
200	269	469	284	484	247	42	242	57	257	247	23
300	269	569	304	604	367	42	342	77	377	367	24
400	269	669	304	704	467	42	442	77	477	467	25
500	269	769	324	824	587	42	542	97	597	587	26
600	269	869	324	924	687	42	642	97	697	687	27
800	269	1069	344	1144	907	42	842	117	917	907	29
1000	269	1269	364	1364	1127	42	1042	137	1137	1127	30
1200	269	1469	379	1579	1342	42	1242	152	1352	1342	32
1500	269	1769	404	1904	1667	42	1542	177	1677	1667	35

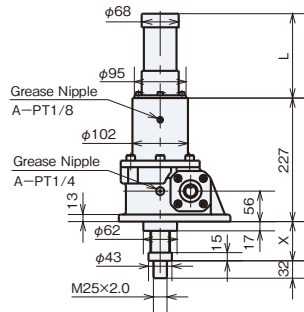
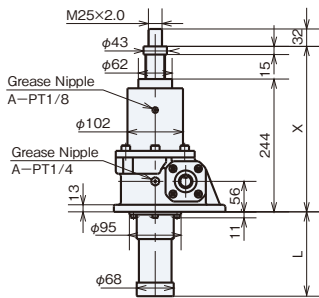

## Output Option

### ■ Bellows ( - J)



### ■ Rod Type End Fitting ( - B)

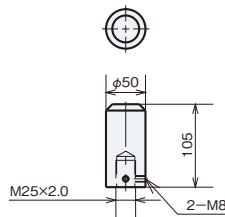

### ■ I Type End Fitting ( - I)

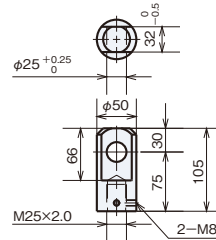

### ■ Table Type End Fitting ( - M)

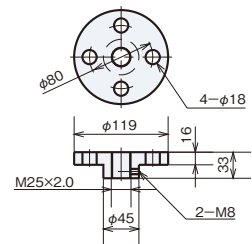

## JWH050 Dimensions - Travel Nut Type

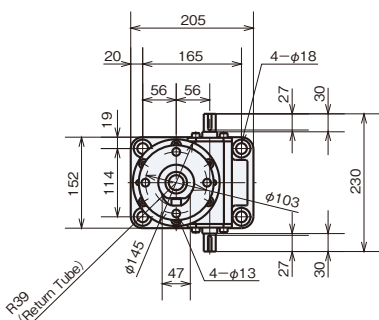

Lift (JWH050UR)

### ● Input Shaft

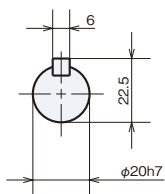

Suspend (JWH050DR)

Stroke	UR Travel Nut Type for Lifting			DR Travel Nut Type for Suspending			Weight kg
	X		Y	X		Y	
	MIN	MAX	Y	MIN	MAX	Y	
100	157	257	369	145	245	257	21
200	157	357	469	145	345	357	22
300	157	457	569	145	445	457	22
400	157	557	669	145	545	557	23
500	157	657	769	145	645	657	24
600	157	757	869	145	745	757	24
800	157	957	1069	145	945	957	26
1000	157	1157	1269	145	1145	1157	27
1200	157	1357	1469	145	1345	1357	29
1500	157	1657	1769	145	1645	1657	31

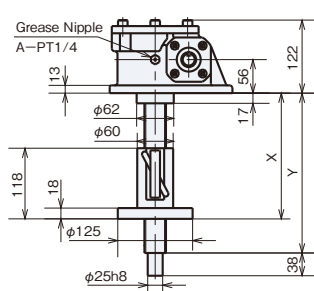
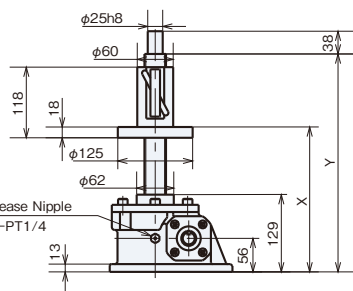

Note) Ball nut return tube and travel flange openings may vary from this drawing. Note the return tube measurements when installing to equipment.

## JWH100 Dimensions - Standard Model

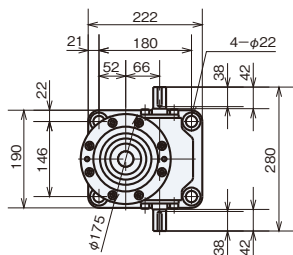

Lift (JWH100US)

### Input Shaft

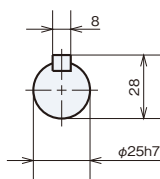

Suspend (JWH100DS)

Stroke	US Standard Model for Lifting				DS Standard Model for Suspending				Weight kg	
	X		X		L	X		L		
	Without Bellows	With Bellows	Without Bellows	With Bellows		Without Bellows	With Bellows			
100	302	402	312	412	151	42	142	52	151	36
200	302	502	312	512	252	42	242	52	252	38
300	302	602	327	627	366	42	342	67	367	41
400	302	702	327	727	466	42	442	67	467	43
500	302	802	352	852	591	42	542	92	592	46
600	302	902	352	952	691	42	642	92	692	48
800	302	1102	367	1167	906	42	842	107	907	53
1000	302	1302	377	1377	1116	42	1042	117	1117	58
1200	302	1502	402	1602	1341	42	1242	142	1342	63
1500	302	1802	427	1927	1666	42	1542	167	1667	71

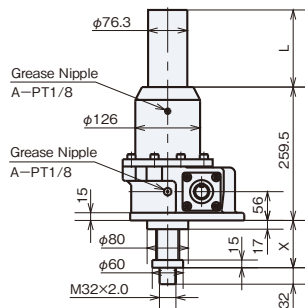
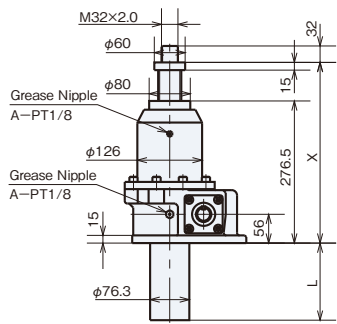

## Output Option

### ■ Bellows ( - J)

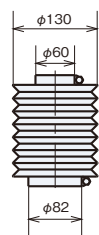

### ■ Rod Type End Fitting ( - B)

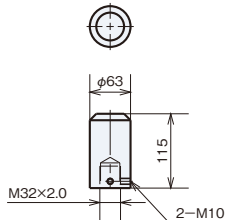

### ■ I Type End Fitting ( - I)

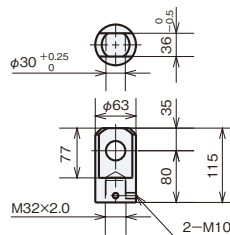

### ■ Table Type End Fitting ( - M)

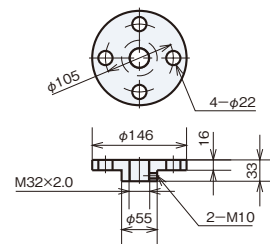

## JWH100 Dimensions - Travel Nut Type

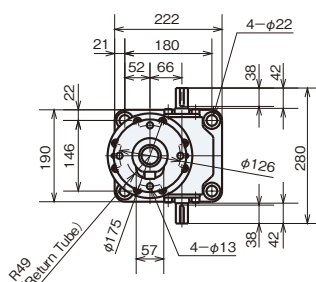

Lift (JWH100UR)

### Input Shaft

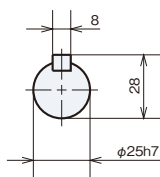

Suspend (JWH100DR)

Stroke	UR Travel Nut Type for Lifting			DR Travel Nut Type for Suspending			Weight kg
	X		Y	X		Y	
	MIN	MAX		MIN	MAX		
100	184	284	414	185	285	295	31
200	184	384	514	185	385	395	32
300	184	484	614	185	485	495	33
400	184	584	714	185	585	595	34
500	184	684	814	185	685	695	35
600	184	784	914	185	785	795	36
800	184	984	1114	185	985	995	39
1000	184	1184	1314	185	1185	1195	41
1200	184	1384	1514	185	1385	1395	43
1500	184	1684	1814	185	1685	1695	46

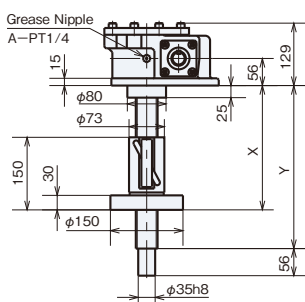
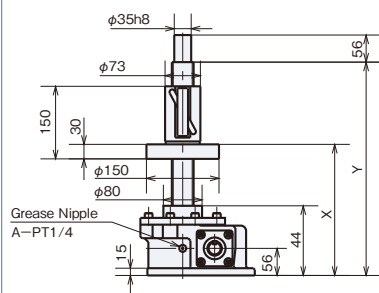

Note) Ball nut return tube and travel flange openings may vary from this drawing. Note the return tube measurements when installing to equipment.

Travel nut type cannot be equipped with optional end fitting (B.I.M). For types with bellows, refer to page 249.

\* For dimensions with no tolerances, general tolerances shall apply, and they may be approximately 2 – 5mm larger than the dimensions shown. For machine design, take margins into consideration.

## JWH150 Dimensions - Standard Model

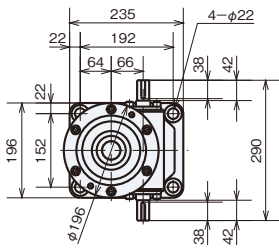

Lift (JWH150US)

### Input Shaft

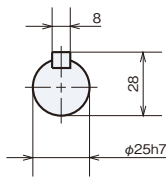

Suspend (JWH150DS)

Stroke	US Standard Model for Lifting				DS Standard Model for Suspending				Weight kg	
	X		X		L	X		L		
	Without Bellows	With Bellows	Without Bellows	With Bellows		Without Bellows	With Bellows			
MIN	MAX	MIN	MAX	MIN	MAX	MIN	MAX			
100	342	442	352	452	151	42	142	52	151	46
200	342	542	352	552	252	42	242	52	252	48
300	342	642	367	667	366	42	342	67	367	51
400	342	742	367	767	466	42	442	67	467	54
500	342	842	392	892	591	42	542	92	591	57
600	342	942	392	992	691	42	642	92	692	60
800	342	1142	407	1207	906	42	842	107	907	65
1000	342	1342	417	1417	1116	42	1042	117	1117	70
1200	342	1542	442	1642	1341	42	1242	142	1342	76
1500	342	1842	467	1967	1666	42	1542	167	1667	84

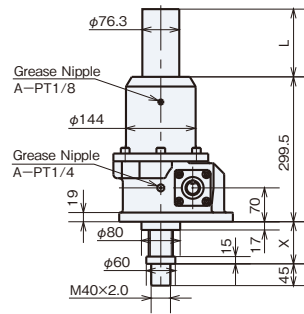
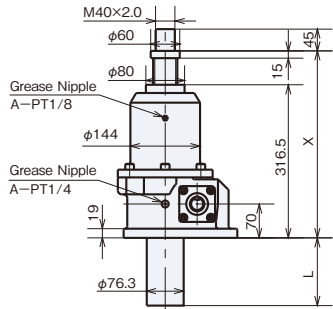

## Output Option

### ■ Bellows ( - J)

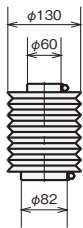

### ■ Rod Type End Fitting ( - B)

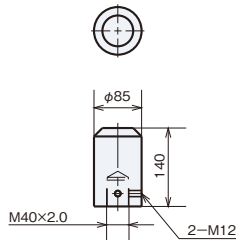

### ■ I Type End Fitting ( - I)

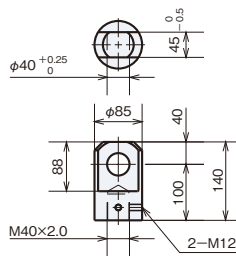

### ■ Table Type End Fitting ( - M)

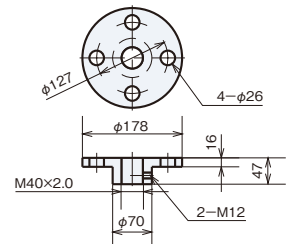

## JWH150 Dimensions - Travel Nut Type

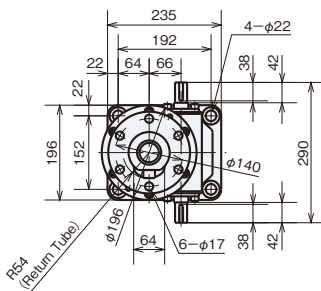

Lift (JWH150UR)

### Input Shaft

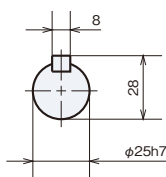

Suspend (JWH150DR)

Stroke	UR Travel Nut Type for Lifting			DR Travel Nut Type for Suspending			Weight kg
	X		Y	X		Y	
	MIN	MAX		MIN	MAX		
100	214	314	448	197	297	308	41
200	214	414	548	197	397	408	42
300	214	514	648	197	497	508	43
400	214	614	748	197	597	608	45
500	214	714	848	197	697	708	46
600	214	814	948	197	797	808	47
800	214	1014	1148	197	997	1008	50
1000	214	1214	1348	197	1197	1208	53
1200	214	1414	1548	197	1397	1408	55
1500	214	1714	1848	197	1697	1708	59

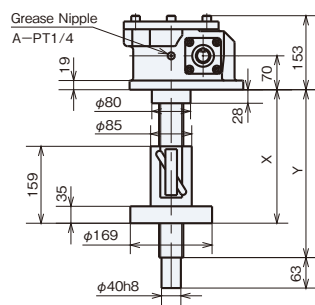
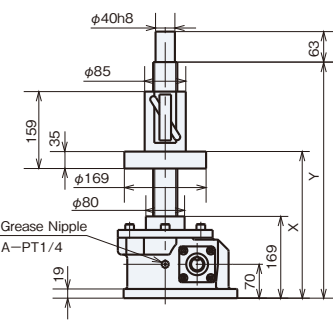

Note) Ball nut return tube and travel flange openings may vary from this drawing. Note the return tube measurements when installing to equipment.

## JWH200 Dimensions - Standard Model

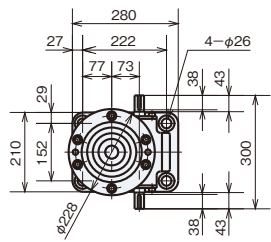

Lift (JWH200US)

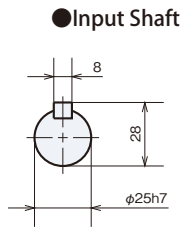

Suspend (JWH200DS)

Stroke	US Standard Model for Lifting					DS Standard Model for Suspending					Weight kg
	X		X		L	X		X		L	
	Without Bellows	With Bellows	Without Bellows	With Bellows		Without Bellows	With Bellows	Without Bellows	With Bellows		
100	406	506	416	516	136	42	142	52	152	136	65
200	406	606	416	616	236	42	242	52	252	236	68
300	406	706	431	731	351	42	342	67	367	351	72
400	406	806	431	831	451	42	442	67	467	451	76
500	406	906	456	956	576	42	542	92	592	576	80
600	406	1006	456	1056	676	42	642	92	692	676	83
800	406	1206	471	1271	891	42	842	107	907	891	90
1000	406	1406	481	1481	1101	42	1042	117	1117	1101	97
1200	406	1606	506	1706	1326	42	1242	142	1342	1326	105
1500	406	1906	531	2031	1651	42	1542	167	1667	1651	115
2000	406	2406	576	2576	2196	42	2042	212	2212	2196	133

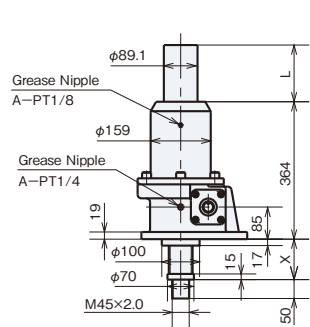
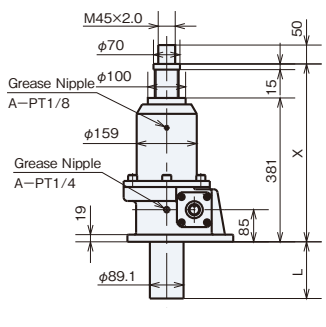

## Output Option

■ Bellows ( - J )

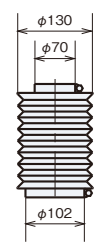

■ Rod Type End Fitting ( - B )

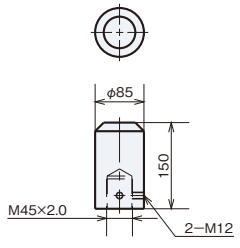

■ I Type End Fitting ( - I )

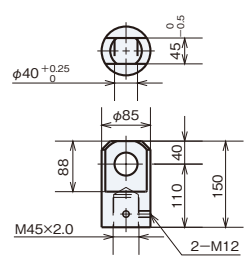

■ Table Type End Fitting ( - M )

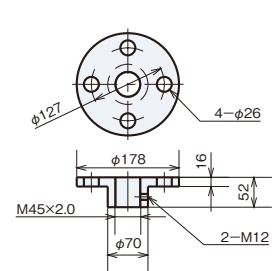

## JWH200 Dimensions - Travel Nut Type

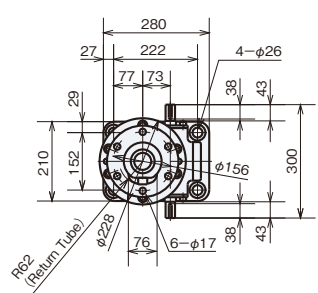

Lift (JWH200UR)

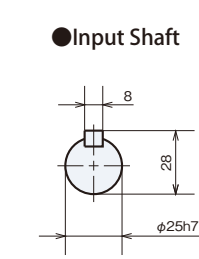

Suspend (JWH200DR)

Stroke	UR Travel Nut Type for Lifting			DR Travel Nut Type for Suspending			Weight kg
	X		Y	X		Y	
	MIN	MAX		MIN	MAX		
100	237	337	503	232	332	342	56
200	237	437	603	232	432	442	58
300	237	537	703	232	532	542	60
400	237	637	803	232	632	642	62
500	237	737	903	232	732	742	65
600	237	837	1003	232	832	842	67
800	237	1037	1203	232	1032	1042	71
1000	237	1237	1403	232	1232	1242	76
1200	237	1437	1603	232	1432	1442	80
1500	237	1737	1903	232	1732	1742	86
2000	237	2237	2403	232	2232	2242	97

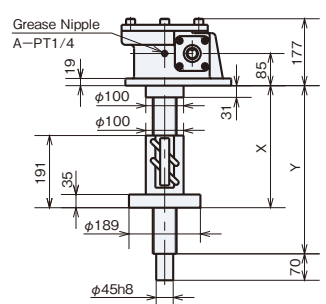
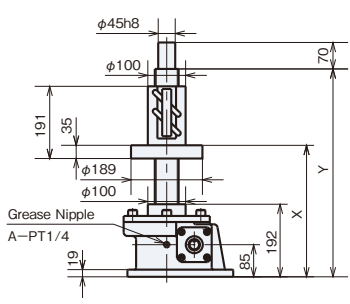

Note) Ball nut return tube and travel flange openings may vary from this drawing. Note the return tube measurements when installing to equipment.

Travel nut type cannot be equipped with optional end fitting (B.I.M). For types with bellows, refer to page 249.  
 \* For dimensions with no tolerances, general tolerances shall apply, and they may be approximately 2 - 5mm larger than the dimensions shown. For machine design, take margins into consideration.



# Warning

## ■ Cautions for selecting

- Duty cycle of JWH (High Lead Screw Type) is within 30% ED. Duty cycle is a ratio of operating time per 30 min on the basis of 30 min interval.
- JWH (High Lead Screw Type) does not have a self-locking device, therefore, a brake mechanism is required.
- Activating torque for the drive unit should be maintained at 200% above the required torque.
- Allowable input rotation speed of linear power jack is 1800 r/min, however, when inputting a speed exceeding the maximum input rotation speed at the basic capacity, check the screw shaft speed (elevation speed) and allowable load related graphs on page 157.
- Select a stroke for the jack with an extra margin with respect to the used stroke.  
JWH (High Lead Screw Type) is equipped with a fall stop, however, if the stroke range is exceeded, the screw shaft falls out.
- Rotating force is generated on the screw shaft (travel nut in the case of travel nut type) with thrust, therefore, rotation prevention is required. Screw rotation torque at the basic capacity is described in the standard specification list. When operating with the end unconnected, and pulling the rope with a sheave installed, use the rotation prevention type.  
Rotation prevention type of JWH (High Lead Screw Type) is of special specification, therefore, contact TSUBAKI E&M.  
However, the rotation prevention type cannot be manufactured for the travel nut type, therefore, provide a rotation prevention mechanism on the device.
- Bellows is of special specification, therefore, contact TSUBAKI E&M.
- When installing a sprocket, gear, or belt to the input or output shaft, confirm that any overhang load applied to the shaft decreases to the allowable OHL or less.

$$\text{Allowable O. H. L.} \geq \frac{T \times f \times L_f}{R}$$

O.H.L. : Overhang load N (kgf)  
 T : Input torque N · m (kgf · m)  
 f : Coefficient - power transmission element  
 L<sub>f</sub> : Coefficient - Load operating position  
 R : Sprocket, Gear, V pulley or Pitch diameter m

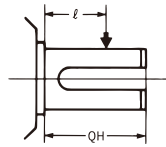

Q : Shaft Length  
 l : Loaded Position

### ● Coefficient – Power Transmission Element (f)

Sprocket	1.00
Gear	1.25
V-belt	1.50
Flat belt	2.50

### ● Coefficient (L<sub>f</sub>) – Load Position

l / QH	0.25	0.38	0.5	0.75	1
L <sub>f</sub>	0.8	0.9	1	1.5	2

### ● Allowable O.H.L.

Frame No.		002	005	010	025	050	100	150	200	300	500	750	1000
JWH (High Lead Screw Type)	N	—	—	530	980	1510	2390	3130	3840	—	—	—	—
H Speed	{ kgf }	—	—	{54}	{100}	{154}	{244}	{320}	{392}	—	—	—	—

## ■ Precautions for installation

- Some screw covers of jacks are made of hard vinyl chloride pipe. Do not lift jack and transport with this pipe, which may result in dropping.
- JWH (High Lead Screw Type) rotates by self weight of the screw shaft or travel nut, therefore, retract its stroke to the minimum and provide a rotation prevention for installation.
- Take jack coasting amount into consideration to set the stroke adjusting limit switch.

## ■ Precautions for use

- Do not perform manual operation from the input shaft with load applied. The input shaft is rotated by the load, which is dangerous.
- When JWH (High Lead Screw Type) is used in the vertical direction, the jack may be reversed by the load because of its excellent efficiency. Never perform manual operation.
- Do not use mechanical stops under any circumstances.
- Operating Environment for jack is as follows.

Operating place	Indoor room which cannot be splashed with rain or water.
Ambient atmosphere	Dust volume comparable to general factories.
Operating temperature range	−15 to 80°C (Refer to section 3 in general precautions.)
Relative humidity	85% or less (no dew condensation)

- Operating part and reducer unit are factory greased. Therefore, use jack as delivered.
- For lubrication grease, lubrication cycle and lubrication amount to the screw shaft and reducer unit, refer to page 253.
- Inspect regularly for general backlash and screw unit condition. Jack life and replacement timing are determined by the following:  
 Metal particles due to wear on the screw surface are visible.  
 Replace gear when its input shaft exceeds 30 rpm with backlash (rattle between input shaft and worm wheel) at H speed, or exceeds 60 rpm at L speed.  
 In either case, if it is used at the replacement timing, this may cause rotation failure of screw shaft and input shaft, and further sudden drop of travel nut.

Linipower Jack

# Options

## Jacks with Motors

Gearmotor	_____	P229~232
Motor	_____	P233~235
Hypoid Motor	_____	P236
Servo Motor	_____	P236

## Control Option

Jack Control System	_____	P237•238
LS Counter	_____	P239•240
Position Sensors	_____	P241~244
Internal LS	_____	P242
Potentiometer	_____	P242•243
( Stroke Display Meter, Printed Circuit Board, ) Meter Relay		
Rotary Encoder	_____	P244

## Others

Clevis and Trunnion Mounting Adapters	_____	P245
Hand Wheel, Columns	_____	P246
Safety Caps	_____	P247
Bellows	_____	P248
<b>Bellows Inquiry Form for travel nut type</b>	_____	P249

## With Gearmotor JWM (Machine Screw Type)



Model No.	Motor Weight	Gear Ratio	Jack Gear Ratio H			
			50Hz (1500r/min)		60Hz (1800r/min)	
			Shaft Speed mm/min (mm/s)	Thrust kN {kgf}	Shaft Speed mm/min (mm/s)	Thrust kN {kgf}
JWM005	25W	1/5	216 (3.6)	1.27 {130}	258 (4.3)	1.08 {110}
		1/10	108 (1.8)	2.55 {260}	126 (2.1)	2.16 {220}
JWM010	40W	1/5	210 (3.5)	1.76 {180}	258 (4.3)	1.47 {150}
		1/10	108 (1.8)	3.63 {370}	126 (2.1)	2.84 {290}
JWM025	0.1kW	1/5	252 (4.2)	4.41 {450}	300 (5.0)	3.63 {370}
		1/10	126 (2.1)	8.92 {910}	150 (2.5)	7.55 {770}
		1/15	84 (1.4)	13.6 {1390}	102 (1.7)	11.3 {1150}
		1/20	60 (1.0)	18.6 {1900}	78 (1.3)	15.0 {1530}
	0.2kW	1/25	48 (0.8)	23.2 {2370}	60 (1.0)	18.6 {1900}
		1/5	252 (4.2)	8.92 {910}	300 (5.0)	7.45 {760}
		1/10	126 (2.1)	18.6 {1900}	150 (2.5)	15.0 {1530}
		1/15	84 (1.4)	24.5 {2500}	102 (1.7)	23.2 {2370}
JWM050	0.2kW	1/5	402 (6.7)	5.88 {600}	480 (8.0)	4.80 {490}
		1/10	198 (3.3)	11.8 {1200}	240 (4.0)	9.80 {1000}
		1/15	132 (2.2)	18.2 {1860}	162 (2.7)	15.2 {1550}
		1/20	102 (1.7)	23.3 {2380}	120 (2.0)	20.3 {2070}
	0.4kW	1/25	78 (1.3)	29.4 {3000}	96 (1.6)	24.3 {2480}
		1/5	402 (6.7)	12.4 {1270}	480 (8.0)	10.3 {1050}
		1/10	198 (3.3)	25.4 {2590}	240 (4.0)	21.3 {2170}
		1/15	132 (2.2)	37.5 {3830}	162 (2.7)	31.5 {3210}
1/20	102 (1.7)	49.0 {5000}	120 (2.0)	41.7 {4250}		
JWM100	0.4kW	1/5	378 (6.3)	13.2 {1350}	450 (7.5)	11.0 {1120}
		1/10	186 (3.1)	27.0 {2760}	228 (3.8)	22.7 {2320}
		1/15	126 (2.1)	40.1 {4090}	150 (2.5)	33.5 {3420}
		1/20	96 (1.6)	53.0 {5410}	114 (1.9)	44.4 {4530}
		1/25	78 (1.3)	67.1 {6850}	90 (1.5)	55.3 {5640}
	0.75kW	1/30	60 (1.0)	80.2 {8180}	78 (1.3)	67.1 {6850}
		1/5	378 (6.3)	24.9 {2540}	450 (7.5)	20.8 {2120}
		1/10	186 (3.1)	49.8 {5080}	228 (3.8)	42.2 {4310}
		1/15	126 (2.1)	74.8 {7630}	150 (2.5)	62.8 {6410}
		1/20	96 (1.6)	98.0 {10000}	114 (1.9)	83.4 {8510}
JWM150	0.4kW	1/5	378 (6.3)	12.1 {1230}	450 (7.5)	10.0 {1020}
		1/10	186 (3.1)	24.6 {2510}	228 (3.8)	20.7 {2110}
		1/15	126 (2.1)	36.5 {3720}	150 (2.5)	30.5 {3110}
		1/20	96 (1.6)	48.2 {4920}	114 (1.9)	40.4 {4120}
		1/25	78 (1.3)	61.1 {6230}	90 (1.5)	50.2 {5120}
	0.75kW	1/30	60 (1.0)	69.9 {7130}	78 (1.3)	61.1 {6230}
		1/5	378 (6.3)	22.6 {2310}	450 (7.5)	18.9 {1930}
		1/10	186 (3.1)	45.3 {4620}	228 (3.8)	38.4 {3920}
		1/15	126 (2.1)	67.9 {6930}	150 (2.5)	57.1 {5830}
		1/20	96 (1.6)	91.5 {9340}	114 (1.9)	75.9 {7740}
1/25	78 (1.3)	114 {11660}	90 (1.5)	94.6 {9650}		
JWM200	0.75kW	1/5	450 (7.5)	18.9 {1930}	540 (9.0)	15.7 {1600}
		1/10	228 (3.8)	37.7 {3850}	270 (4.5)	31.9 {3260}
		1/15	150 (2.5)	56.6 {5780}	180 (3.0)	47.5 {4850}
		1/20	114 (1.9)	76.3 {7790}	138 (2.3)	63.2 {6450}
		1/25	90 (1.5)	95.2 {9710}	108 (1.8)	78.8 {8040}
	1.5kW	1/5	450 (7.5)	37.9 {3870}	540 (9.0)	31.5 {3220}
		1/10	228 (3.8)	76.3 {7790}	270 (4.5)	63.2 {6450}
		1/15	150 (2.5)	114 {11640}	180 (3.0)	95.1 {9710}
		1/20	114 (1.9)	151 {15490}	138 (2.3)	126 {12900}
1/25	90 (1.5)	189 {19350}	108 (1.8)	158 {16160}		

- : Standard
- : Rush Order
- : Made-to-Order

\* Other shaft speeds and thrusts also available.

\* Values in striped cells  indicate thrust rates that exceed allowable capacities. Be sure to adjust thrust to below these rates.

\* These thrust rates do not take allowable buckling rates into account. Consider as necessary.



## With Gearmotor JWB (Ball Screw Type)



Model No.	Motor Weight	Gear Ratio	Jack Gear Ratio H			
			50Hz (1500r/min)		60Hz (1800r/min)	
			Shaft Speed mm/min (mm/s)	Thrust kN {kgf}	Shaft Speed mm/min (mm/s)	Thrust kN {kgf}
JWB005	25W	1/5	270 (4.5)	2.55 {260}	318 (5.3)	2.16 {220}
		1/10	138 (2.3)	4.90 {500}	162 (2.7)	4.21 {430}
JWB010	40W	1/5	264 (4.4)	4.12 {420}	318 (5.3)	3.43 {350}
		1/10	132 (2.2)	8.62 {880}	162 (2.7)	6.66 {680}
JWB025	0.1kW	1/5	402 (6.7)	8.23 {840}	480 (8.0)	6.86 {700}
		1/10	198 (3.3)	16.6 {1690}	240 (4.0)	14.0 {1430}
	1/15	132 (2.2)	24.5 {2500}	162 (2.7)	20.9 {2130}	
JWB050	0.2kW	1/5	498 (8.3)	13.6 {1390}	600 (10)	11.3 {1150}
		1/10	252 (4.2)	28.3 {2890}	300 (5.0)	22.8 {2330}
	1/15	168 (2.8)	42.5 {4340}	198 (3.3)	35.4 {3610}	
JWB100	0.4kW	1/5	450 (7.5)	31.8 {3240}	540 (9.0)	26.4 {2690}
		1/10	228 (3.8)	64.6 {6590}	270 (4.5)	54.2 {5530}
	1/15	150 (2.5)	95.6 {9760}	180 (3.0)	80.2 {8180}	
JWB150	0.4kW	1/5	600 (10)	23.8 {2430}	720 (12)	19.7 {2010}
		1/10	300 (5.0)	48.4 {4940}	360 (6.0)	40.7 {4150}
	1/15	198 (3.3)	71.7 {7320}	240 (4.0)	60.1 {6130}	
JWB200	0.75kW	1/5	600 (10)	44.0 {4490}	720 (12)	36.6 {3730}
		1/10	300 (5.0)	87.7 {8950}	360 (6.0)	74.4 {7590}
	1/15	198 (3.3)	132 {13440}	240 (4.0)	111 {11290}	
JWB200	1.5kW	1/5	600 (10)	88.1 {8990}	720 (12)	73.4 {7490}
		1/10	300 (5.0)	177 {18110}	360 (6.0)	147 {14990}

## With Gearmotor JWH (High Lead Ball Screw Type)



Model No.	Motor Weight	Gear Ratio	Jack Gear Ratio H			
			50Hz (1500r/min)		60Hz (1800r/min)	
			Shaft Speed mm/min (mm/s)	Thrust kN {kgf}	Shaft Speed mm/min (mm/s)	Thrust kN {kgf}
JWH010	40W	1/5	1200 (20)	0.98 {100}	1440 (24)	0.88 {90}
		1/10	600 (10)	2.16 {220}	720 (12)	1.67 {170}
JWH025	0.1kW	1/5	1260 (21)	2.74 {280}	1500 (25)	2.25 {230}
		1/10	600 (10)	5.49 {560}	780 (13)	4.70 {480}
JWH050	0.2kW	1/5	1260 (21)	5.49 {560}	1500 (25)	4.61 {470}
		1/10	600 (10)	11.5 {1170}	780 (13)	9.31 {950}
JWH100	0.4kW	1/5	1260 (21)	5.78 {590}	1500 (25)	4.80 {490}
		1/10	600 (10)	12.1 {1230}	780 (13)	9.70 {990}
JWH150	0.75kW	1/5	1260 (21)	12.3 {1260}	1500 (25)	10.2 {1040}
		1/10	600 (10)	25.1 {2560}	780 (13)	21.1 {2150}
JWH200	1.5kW	1/5	1200 (20)	12.3 {1250}	1440 (24)	10.2 {1040}
		1/10	600 (10)	25.0 {2550}	720 (12)	21.0 {2140}

: Standard  
 : Rush Order  
 : Made-to-Order

\* Other shaft speeds and thrusts also available.  
 \* Values in striped cells  indicate thrust rates that exceed allowable capacities. Be sure to adjust thrust to below these rates.  
 \* These thrust rates do not take allowable buckling rates into account. Consider as necessary.

# Outline Drawings for Motored Jacks

## Standard Gearmotor Mounting

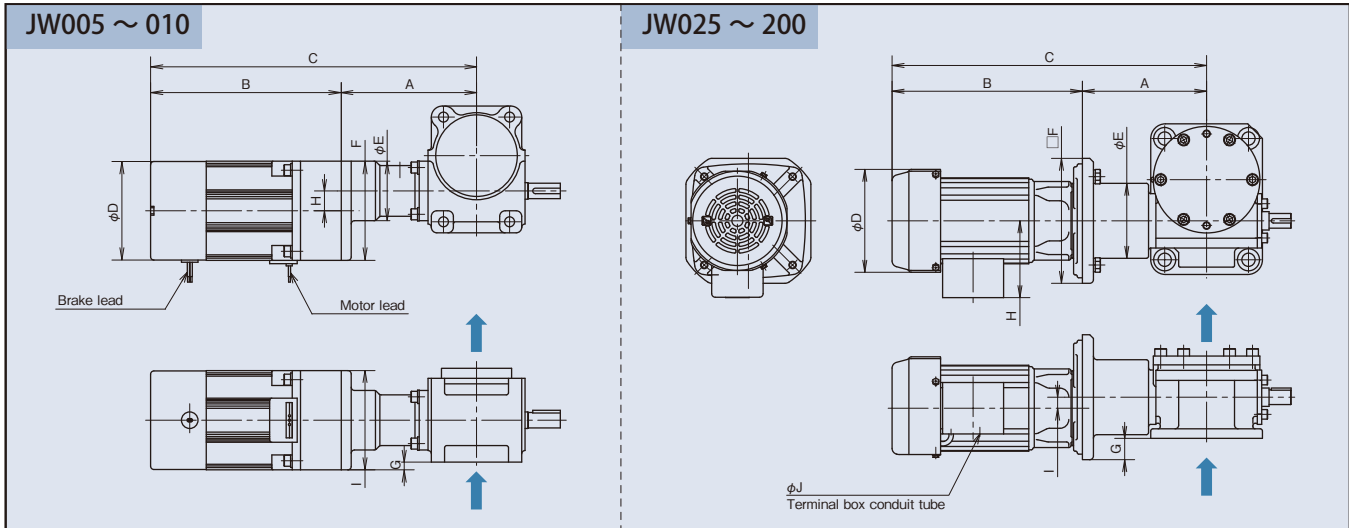

Note) For standard (US, DS) and rotation prevention types (UM, DM), screw shafts will lift in the direction of with normal wiring.  
For travel nut types (UR,DR), nuts will lift in the direction of with normal wiring.

## Gearmotor Mounting on the Opposite Side

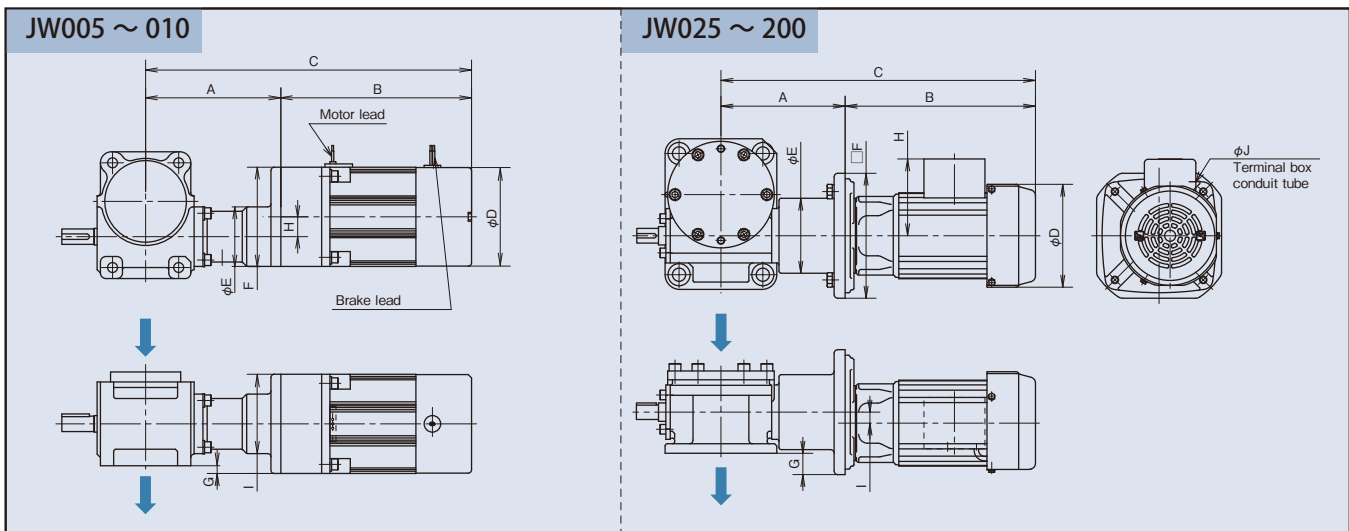

Note) For standard (US, DS) and rotation prevention types (UM, DM), screw shafts will lift in the direction of with normal wiring.  
For travel nut types (UR,DR), nuts will lift in the direction of with normal wiring.

Unit: mm

Frame No.	Motor Weight	A	B	C	D	E	F	G	H	I	J
JW005	25W	106	160	266	84	60	85	15	15	80	—
JW010	40W	123	188	311	93	54	90	7	18	90	—
JW025	0.1kW	144	242	386	140	93	170	40	105	15	12
	0.2kW	144	259	403	140	93	170	40	105	15	12
JW050	0.2kW	169	259	428	140	102	170	29	105	15	12
	0.4kW	191	301	492	140	102	200	44	105	18	12
JW100	0.4kW	207	301(323)	508(530)	140	131	200	44	105	18(23)	12
	0.75kW	207	353	558	158	131	200	44	114	23	12
JW150	0.4kW	211	301(323)	512(534)	140	131	200	30	105	18(23)	12
	0.75kW	211	353	564	158	131	200	30	114	23	12
JW200	0.75kW	231	353	584	158	144	200	15	114	23	12
	1.5kW	246	461	707	198	150	280	55	143	27	27

\* ( ) assumes 1/30 rpm.

## Standard Gearmotor

Output	25W ~ 40W	0.1kW ~ 1.5kW
Model	With Brake/Totally Enclosed	
Voltage	200/200/220V	
Frequency	50/60/60Hz	
Pole	4P	
Phase	3 Phase	
Protection	IP20	
Rating	Continuous	
Insulation Class	E	

## Specialized Gearmotor

Specifications	25W ~ 40W	0.1kW ~ 1.5kW	1.5kW
Single Phase 100V 50/60Hz	○	○ (100W,200W only)	—
Inverter Motor	—	○	○
Out door Use (IP55)	—	○	○
400V Class Voltage	△*	○	○
Special Voltage	—	○	○
Global Use (CCC,CE,UL)	△*	○	—
One touch brake manual release	—	○	○
Manual shaft	—	○	○
Rotary encoder	—	○	○

\* Consult TEM

## Motor current value and brake current value

Output and frame No.	Motor current value (A)			Brake model No.	Brake current value (A)		
	200V 50Hz	200V 60Hz	220V 60Hz		200V 50Hz	200V 60Hz	220V 60Hz
4P - 25W	0.25	0.22	0.23	/	0.03	0.03	0.03
4P - 40W	0.31	0.29	0.28		0.07	0.07	0.08
4P - 0.1 kW	0.63	0.57	0.58	SLB01	0.178	0.178	0.178
4P - 0.2 kW	1.2	1.1	1.1	SLB02	0.178	0.178	0.178
4P - 0.75kW	3.8	3.4	3.4	SLB07	0.273	0.273	0.273
4P - 1.5 kW	7.0	6.2	6.0	SLB15	0.289	0.289	0.289

Note) 1. The above values are the rated current values of motors and brakes.

They are given for reference because they may differ according to the actually acting thrust, jack efficiency, etc.

2. The rated current values do not include brake current values.

3. The brake current values show the values on the secondary side of the power supply module (0.1kW up to 1.5kW).

## Circuit Diagrams

### Circuit Diagrams for 25~40W

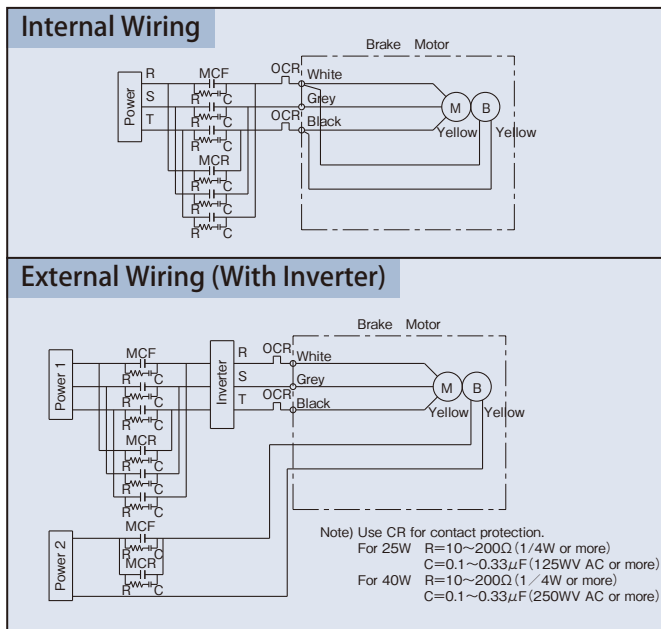

### Circuit Diagrams for 0.1~1.5kW

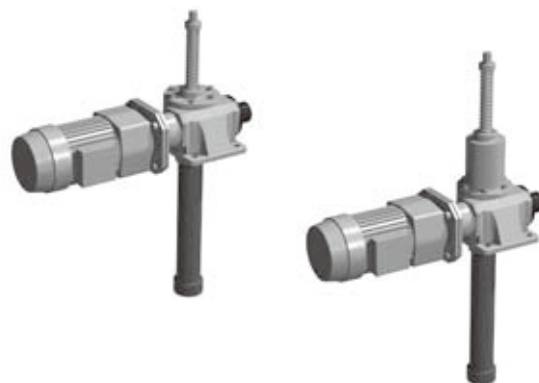
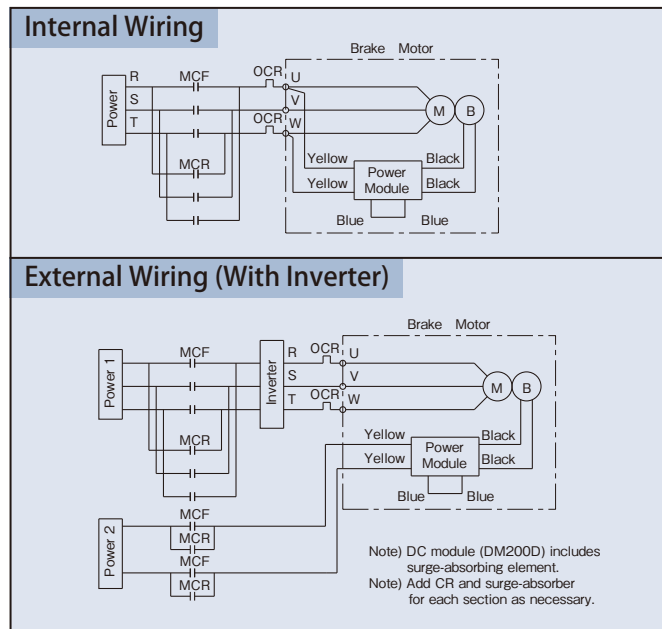

## With Motor JWM (Machine Screw Type)

Model No.	Motor Weight	Jack Gear Ratio H			
		50Hz (1500r/min)		60Hz (1800r/min)	
		Shaft Speed mm/min (mm/s)	Thrust kN {kgf}	Shaft Speed mm/min (mm/s)	Thrust kN {kgf}
JWM025	0.2kW	1260 (21)	1.96 {200}	1500 (25)	1.66 {170}
	0.4kW	1260 (21)	4.02 {410}	1500 (25)	3.33 {340}
	0.75kW	1260 (21)	7.55 {770}	1500 (25)	6.27 {640}
	1.5kW	1260 (21)	10.0 {1020}	1500 (25)	8.33 {850}
JWM050	0.75kW	1980 (33)	4.98 {508}	2400 (40)	4.12 {420}
	1.5kW	1980 (33)	9.80 {1000}	2400 (40)	8.23 {840}
JWM100	2.2kW	1860 (31)	15.5 {1580}	2280 (38)	12.8 {1310}
	3.7kW	1860 (31)	19.6 {2000}	2280 (38)	16.4 {1670}
JWM150	2.2kW	1860 (31)	14.0 {1430}	2280 (38)	11.7 {1190}
	3.7kW	1860 (31)	19.8 {2020}	2280 (38)	16.4 {1670}
JWM200	2.2kW	2280 (38)	11.7 {1190}	2700 (45)	9.70 {990}
	3.7kW	2280 (38)	19.7 {2010}	2700 (45)	16.4 {1670}

## With Motor JWB (Ball Screw Type)

Model No.	Motor Weight	Jack Gear Ratio H			
		50Hz (1500r/min)		60Hz (1800r/min)	
		Shaft Speed mm/min (mm/s)	Thrust kN {kgf}	Shaft Speed mm/min (mm/s)	Thrust kN {kgf}
JWB025	0.2kW	1980 (33)	3.72 {380}	2400 (40)	3.13 {320}
	0.4kW	1980 (33)	7.45 {760}	2400 (40)	6.27 {640}
	0.75kW	1980 (33)	14.0 {1430}	2400 (40)	11.7 {1190}
	1.5kW	1980 (33)	24.4 {2490}	2400 (40)	20.0 {2050}
JWB050	0.75kW	2520 (42)	11.6 {1180}	3000 (50)	9.60 {980}
	1.5kW	2520 (42)	22.9 {2340}	3000 (50)	19.1 {1950}
JWB100	2.2kW	2280 (38)	36.9 {3770}	2700 (45)	30.8 {3140}
	3.7kW	2280 (38)	59.5 {6080}	2700 (45)	50.3 {5140}
JWB150	2.2kW	3000 (50)	27.7 {2830}	3600 (60)	23.0 {2350}
	3.7kW	3000 (50)	46.6 {4750}	3600 (60)	38.7 {3950}
JWB200	2.2kW	3000 (50)	27.2 {2780}	3600 (60)	22.6 {2310}
	3.7kW	3000 (50)	45.8 {4670}	3600 (60)	38.1 {3890}

## With Motor JWH (High Lead Ball Screw Type)

Model No.	Motor Weight	Jack Gear Ratio H			
		50Hz (1500r/min)		60Hz (1800r/min)	
		Shaft Speed mm/min (mm/s)	Thrust kN {kgf}	Shaft Speed mm/min (mm/s)	Thrust kN {kgf}
JWH025	0.4kW	6240 (104)	2.45 {250}	7500 (125)	2.06 {210}
	0.75kW	6240 (104)	4.70 {480}	7500 (125)	3.92 {400}
	1.5kW	6240 (104)	9.31 {950}	7500 (125)	7.74 {790}
JWH050	0.75kW	6240 (104)	4.90 {500}	7500 (125)	4.12 {420}
	1.5kW	6240 (104)	9.70 {990}	7500 (125)	8.13 {830}
JWH100	2.2kW	6000 (100)	14.3 {1460}	7200 (120)	11.9 {1210}
	3.7kW	6000 (100)	24.0 {2450}	7200 (120)	20.0 {2040}
JWH150	2.2kW	6000 (100)	14.3 {1460}	7200 (120)	11.9 {1210}
	3.7kW	6000 (100)	24.0 {2450}	7200 (120)	20.0 {2040}
JWH200	2.2kW	6000 (100)	14.0 {1430}	7200 (120)	11.7 {1190}
	3.7kW	6000 (100)	23.6 {2410}	7200 (120)	19.7 {2010}

	: Standard
	: Rush Order
	: Made-to-Order

\* Other shaft speeds and thrusts also available.

\* Values in striped cells  indicate thrust rates that exceed allowable capacities. Be sure to adjust thrust to below these rates.

\* These thrust rates do not take allowable buckling rates into account. Consider as necessary.

\* As for worm ratio L, consult TEM.

# Outline Drawings for Motored Jacks

## Standard Gearmotor Mounting

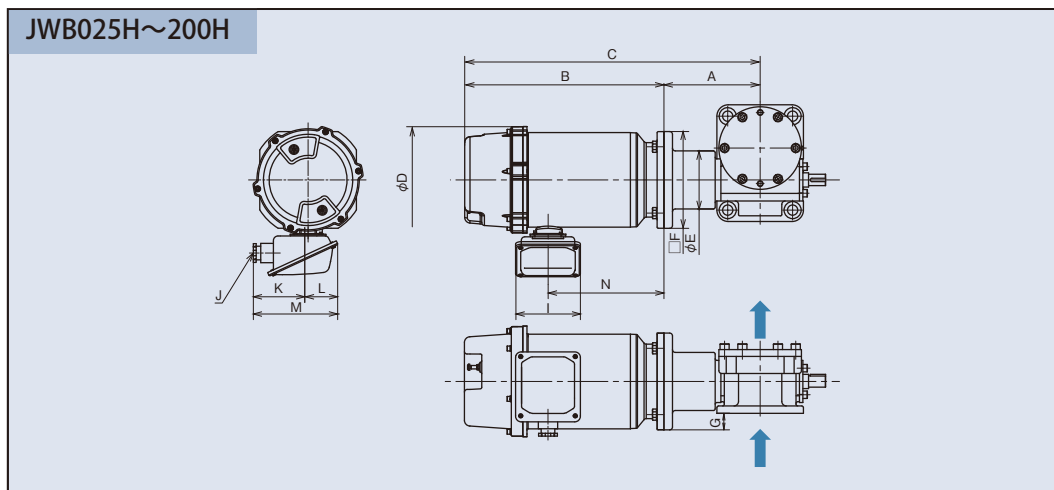

Note) For standard (US, DS) and rotation prevention types (UM, DM), screw shafts will lift in the direction of ➔ with normal wiring.  
 For travel nut types (UR,DR), nuts will lift in the direction of ➔ with normal wiring.

## Gearmotor Mounting on the Opposite Side

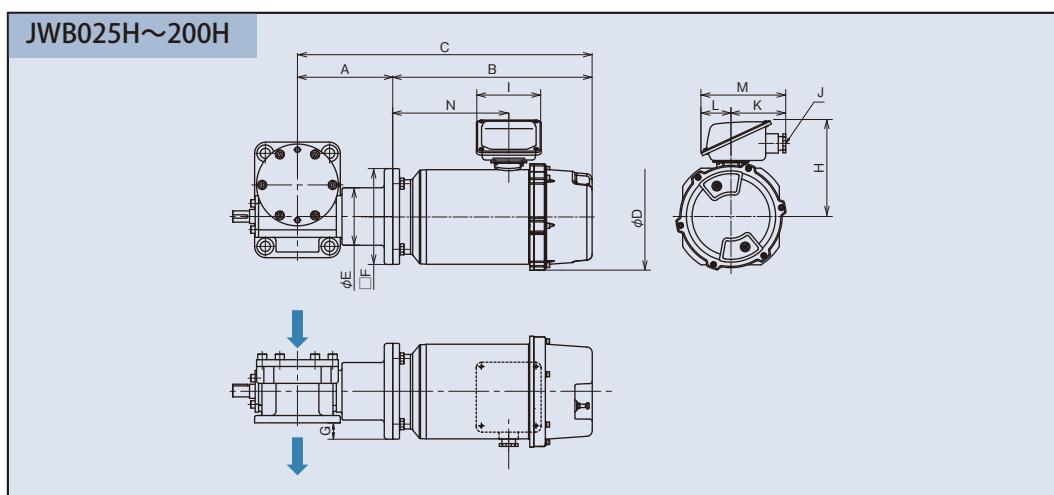

Note) For standard (US, DS) and rotation prevention types (UM, DM), screw shafts will lift in the direction of ➔ with normal wiring.  
 For travel nut types (UR,DR), nuts will lift in the direction of ➔ with normal wiring.

Unit: mm

Frame No.	Motor Weight	A	B	C	D	E	F	G	H	I	J	K	L	M	N
JW025	0.2kW	132	231	363	132	95	120	15	125	84	SK-14L(PF1/2)	79	45	124	112
	0.4kW	139	253	392	132	95	120	15	125	84	SK-14L(PF1/2)	79	45	124	134
	0.75kW	146	289	435	180	102	170	40	166	114	A20C(PF3/4)	106	49	155	145
	1.5kW	146	351	497	194	102	170	40	178	114	A20C(PF3/4)	106	49	155	204
JW050	0.75kW	169	289	458	180	102	170	29	166	114	A20C(PF3/4)	106	49	155	145
	1.5kW	169	351	520	194	102	170	29	178	114	A20C(PF3/4)	106	49	155	204
JW100	2.2kW	207	381	588	207	131	200	44	178	114	A25C(PF1)	110	49	159	213
	3.7kW	207	414	621	229	144	200	44	189	114	A25C(PF1)	110	49	159	239
JW150	2.2kW	211	381	592	207	131	200	44	178	114	A25C(PF1)	110	49	159	213
	3.7kW	211	414	625	229	144	200	44	189	114	A25C(PF1)	110	49	159	239
JW200	2.2kW	231	381	612	207	131	200	15	178	114	A25C(PF1)	110	49	159	213
	3.7kW	231	414	645	229	144	200	15	189	114	A25C(PF1)	110	49	159	239

## Motor Specifications

Output	0.2kW~0.4kW	0.75kW~3.7kW
Power Source	200/200/220V	
	400/400/440V	
Frequency	50/60/60Hz	
Pole	4P	
Phase	3 Phase	
Protection	IP55	
Rating	S2 30min	
Insulation Class	E (B for 400V)	
With Brake	Electromagnetic Brake (DC, non-excitation type)	

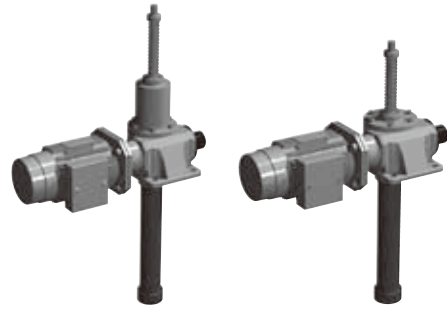

## Motor current value and brake current value

Output and frame No.	Motor current value (A)						Brake model No.	Brake current value (A)					
	200V 50Hz	200V 60Hz	220V 60Hz	400V 50Hz	400V 60Hz	440V 60Hz		200V 50Hz	200V 60Hz	220V 60Hz	400V 50Hz	400V 60Hz	440V 60Hz
4P - 0.2 kW	1.3 (4.91)	1.1 (4.68)	1.1 (5.14)	0.63 (2.40)	0.55 (2.22)	0.56 (2.41)	SBH02LP	0.17 0.26	0.17 0.26	0.17 0.28	0.17 0.26	0.17 0.26	0.17 0.28
4P - 0.4 kW	2.4 (11.6)	2.1 (10.2)	2.1 (11.0)	1.2 (5.14)	1.1 (4.88)	1.1 (5.39)	SBH04LP	0.17 0.26	0.17 0.26	0.17 0.28	0.17 0.26	0.17 0.26	0.17 0.28
4P - 0.75 kW	3.9 (24.0)	3.5 (22.0)	3.4 (24.0)	1.9 (12.0)	1.7 (11.0)	1.7 (12.0)	SLB07LP	0.21 0.28	0.21 0.28	0.23 0.31	0.11 0.15	0.11 0.15	0.12 0.16
4P - 1.5 kW	6.5 (49.0)	6.1 (45.0)	5.8 (50.0)	3.2 (24.5)	3.1 (22.5)	2.9 (25.0)	SLB15LP	0.22 0.29	0.22 0.29	0.24 0.32	0.11 0.15	0.11 0.15	0.12 0.16
4P - 2.2 kW	9.6 (67.0)	9.0 (59.0)	8.6 (64.9)	4.8 (33.5)	4.5 (29.5)	4.3 (32.5)	TB-A2.2	0.25 0.34	0.25 0.34	0.25 0.34	0.13 0.17	0.13 0.17	0.13 0.17
4P - 3.7 kW	15.2 (122)	14.2 (104)	13.6 (114)	7.6 (61.0)	7.2 (51.8)	6.8 (57.0)	TB-A3.7	0.34 0.44	0.34 0.44	0.34 0.44	0.17 0.22	0.17 0.22	0.17 0.22

Note) 1. The above values are rated current values of the motor and brake. A numerical value in parentheses is a start current value of the motor.

2. The rated current values and start current values do not include a brake current value.

3. A DC brake is used as a brake. The upper stage of the brake current value indicates a value on the primary side of the power module, and the lower stage indicates a value on the secondary side.

4. The above values are references because the rated current values for the power cylinder vary depending on operating conditions.

5. For simultaneous turnoff of 0.1kW to 0.4kW, 400V class, the voltage is converted to 200V through the motor intermediate tap to be input. For individual turnoff, decrease the voltage to 200 to 220V by a transformer. The capacity of the transformer capacity shall be 90VA or more.

6. For individual turnoff of 0.75kW or more, 400V class, the DC module is applicable for 400V class, therefore, it is unnecessary to decrease the voltage.

7. For 0.75kW and 1.5kW of 400V class, the brake model Nos. are "SLB07LPV" and "SLB15LPV," respectively.

## Circuit Diagrams

### Circuit Diagrams for 0.2~0.4kW(200V)

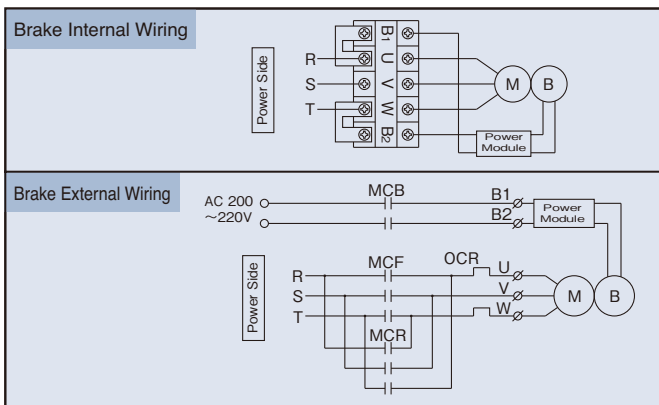

### Circuit Diagrams for 0.75~3.7kW(200V)

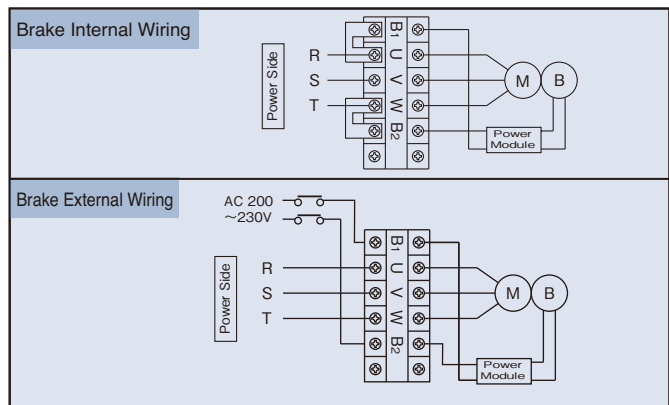

### Circuit Diagrams for 0.2~0.4kW(400V)

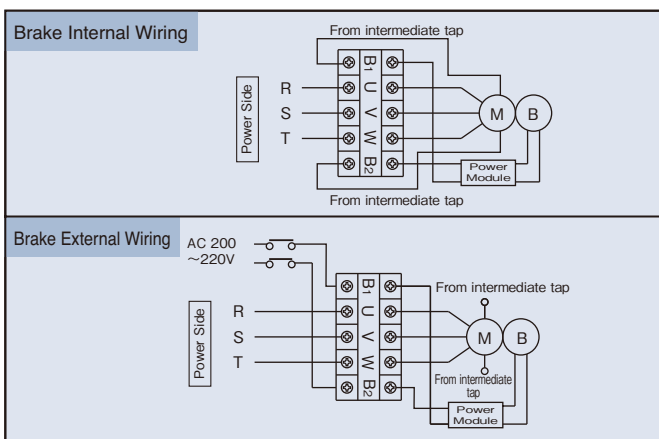

### Circuit Diagrams for 0.75~3.7kW(400V)

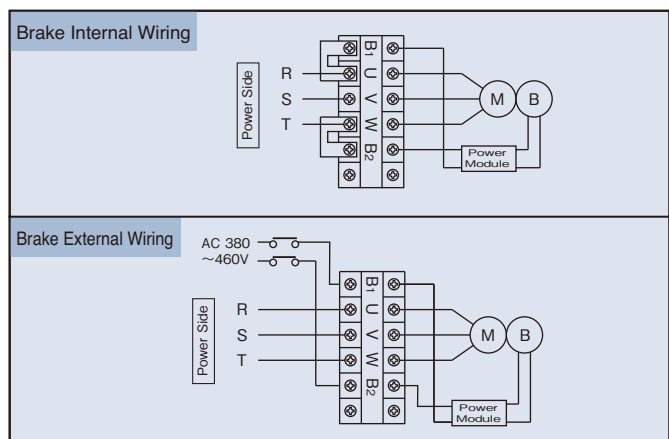

Hypoid Motor Type

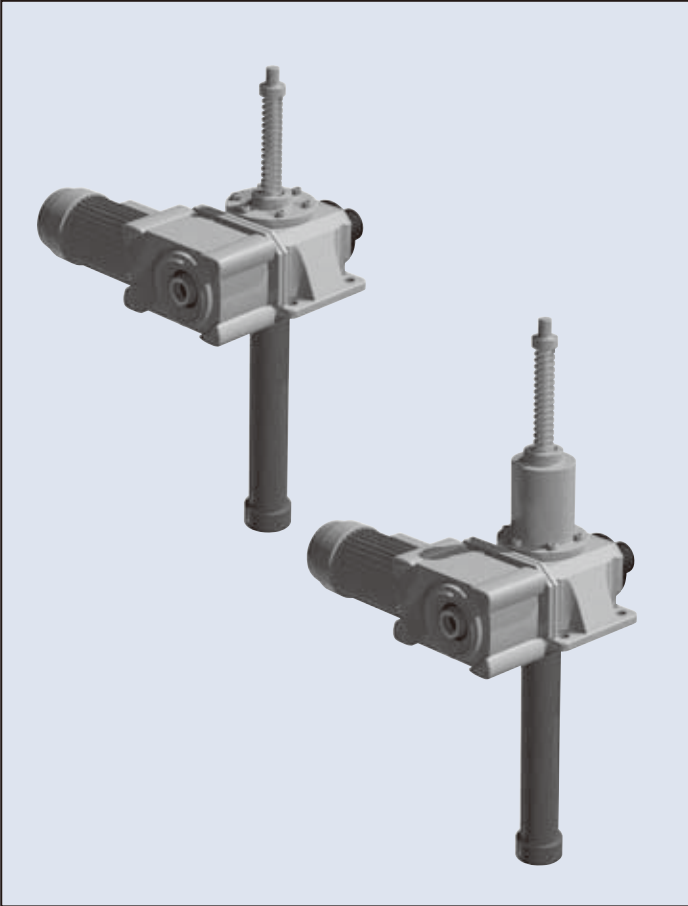

Notes

1. TSUBAKI E&M compact Hypoid Motor is a space saver.
  2. To install, the Hypoid Motor can be adjusted at 90° intervals from the input shaft, based on specific applications.
- \* Hypoid Motor is a space saving right-angle reducer with high starting and running efficiencies. (Another TSUBAKI E&M product)

Servo Motor Type

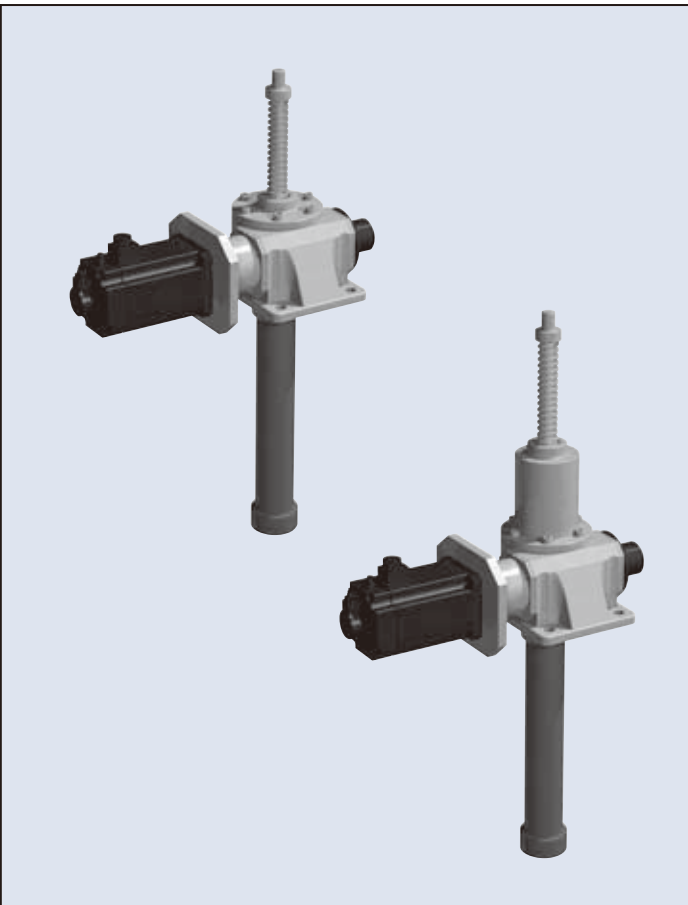

Notes

1. Allows complete control of screw shaft speed.
2. Allows accurate control of stopping.
3. Allows accurate control of force applied to the jack.
4. Maintains load with Servo Lock function.
5. Operates multiple jack systems without mechanical connections.
6. Compatible with any brand of servo motor.



## Jack Control System

We offer various stroke control options to suit your specific needs and conditions. Select from a limit switch, analog device with potentiometer, and digital device with an encoder.

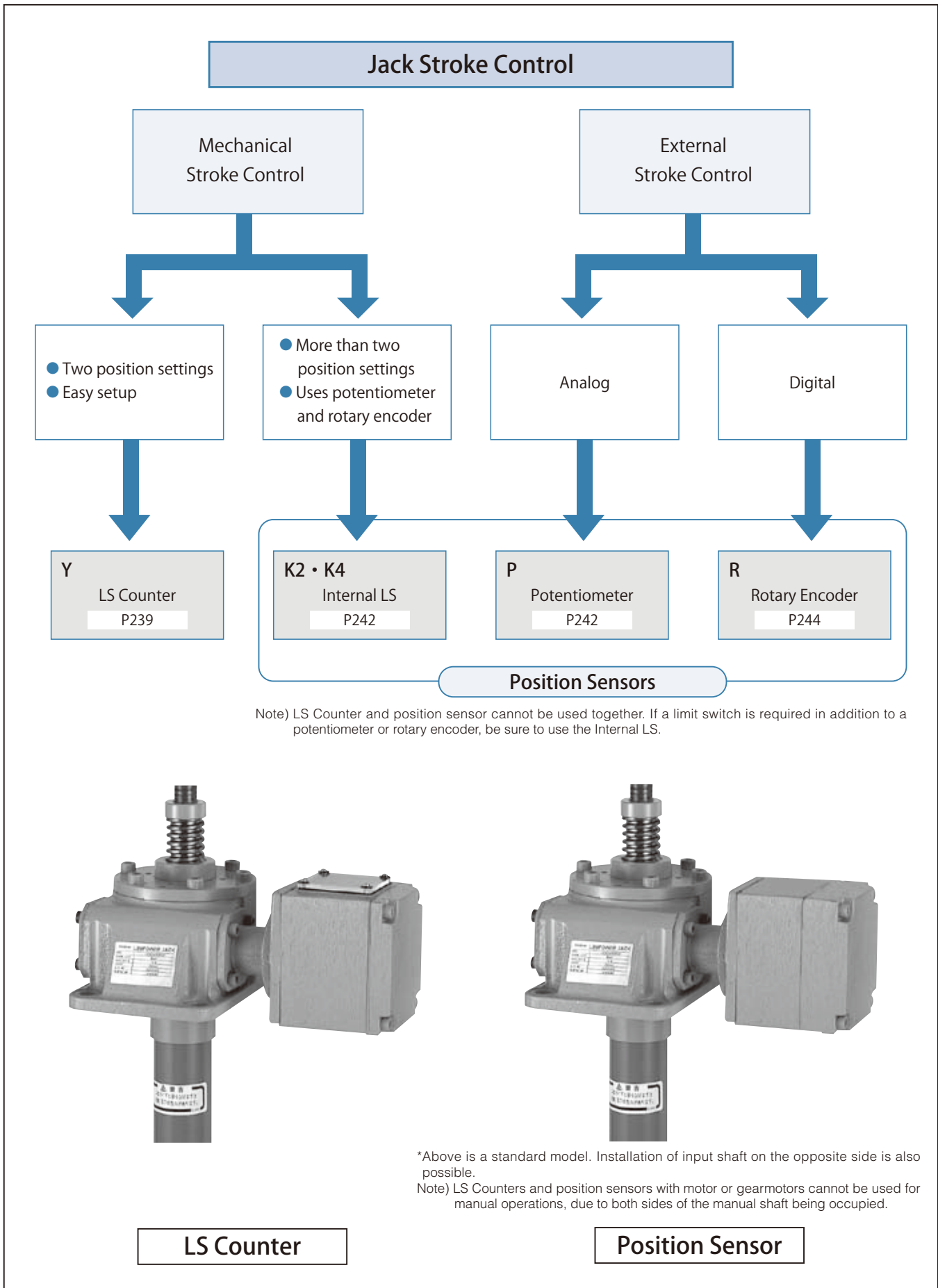

## LS Counter

A compact stroke adjusting device as well as a detection unit that combines a cam mechanism with a microswitch. It can be mounted directly to the input shaft of a jack, and mechanical positioning of upper and lower limits of strokes can easily be performed. Stroke control can be performed only by setting the stop position by the reset button. This economy-type limit switch allows for easy adjustment.

## Position Sensor

- (1) Internal LS  
 (2) Potentiometer  
 (3) Rotary Encoder
- } 3 options are available based on specific needs.  
 A combination of all 3 is also available.

### (1) Internal LS

Can be used in addition to a potentiometer and rotary encoder, and is effective under dusty conditions. 2 or 4 microswitch types available. (K2 or K4)

### (2) Potentiometer

Comes with a convenient meter that displays stroke range, and allows full adjustment of stroke. It also measures changes in stroke resistance. Below are options available with a potentiometer.

- Stroke display meter (PCB provided)
- Meter relay (PCB provided)

### (3) Rotary Encoder

Digital signal of Sequencer or PLC (programmable controller) allows you to control jack stroke. Open collector and line driver output power sources are available. The following option is possible with a rotary encoder.

## LS Counter

A Limit Switch that uses a mechanical counter to accurately measure and adjust stroke at small intervals. It can be mounted directly to the input shaft. Use two counters and limit switches to control both the upper and lower travel limits. Its one-touch reset button also allows you to stop or reset stroke at any time.

Note) LS Counters cannot be used with a rotary encoder or potentiometer. Rotary encoders and potentiometers must be used with a position detection unit (with internal LS).

<b>Form</b>	Mechanical Counter
<b>No. of Counter Digits</b>	5 (1 Count/Input Shaft Revolution)
<b>Allowable Max. Input Rotation</b>	1800r/min
<b>Limit Switch Used</b>	AVT3254 (Matsushita Electronics)
<b>Contact Composition</b>	1 C (Max. and Min. 1 pt. each)
<b>Power Voltage</b>	250V AC 3A
<b>Ambient Temperature</b>	-5 to 40°C

\* LS is not factory adjusted and requires initial setting before use.

\* Take caution so as to avoid water from contacting internal parts while adjusting.

When the limit switch is working, the numbers displayed on the LS Counter unit changes from 00000 to 99999 (or 99999 to 00000).

### ■ Dimensions and Features

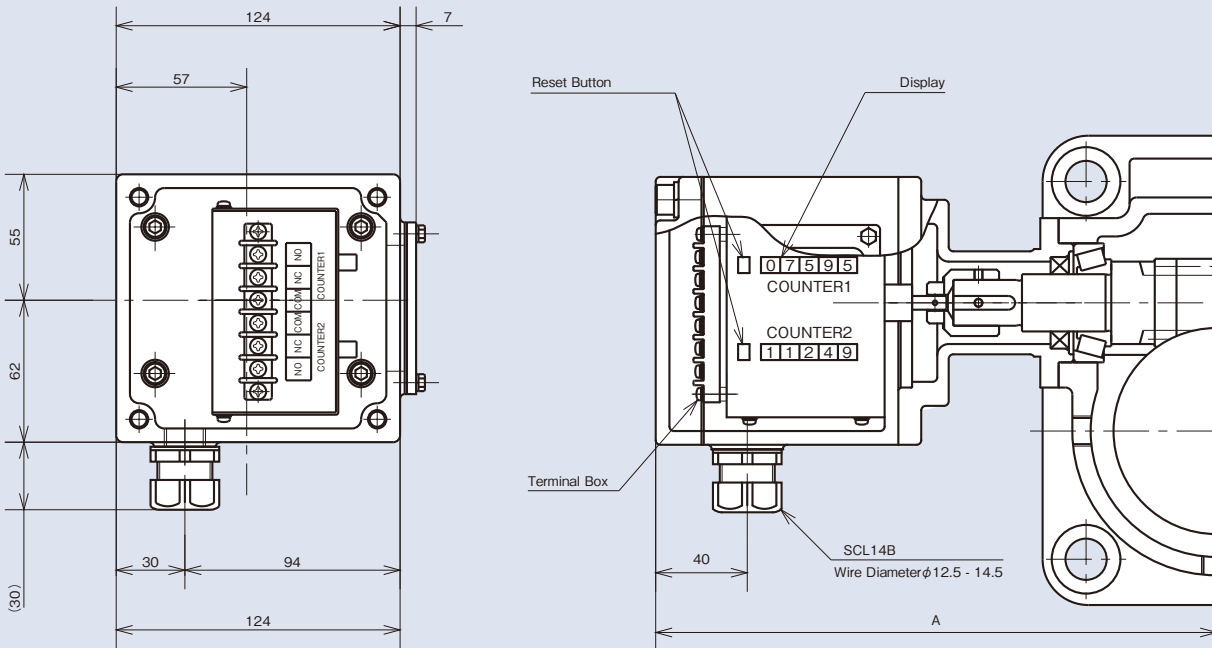

\* The above installation position (left of input shaft) is standard.

Unit: mm

Frame No.	002	005	010	025	050	100	150	200
A	187	187	211	220	245	271	275	280

## Setting the LS Counter

Setting the limit switch is as easy as 1 ~ 6 below.

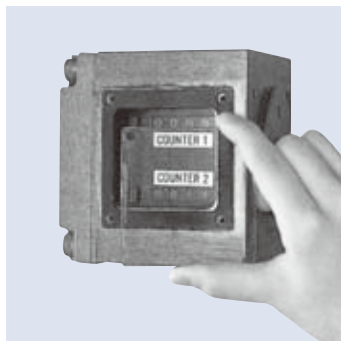

1. Remove cover.

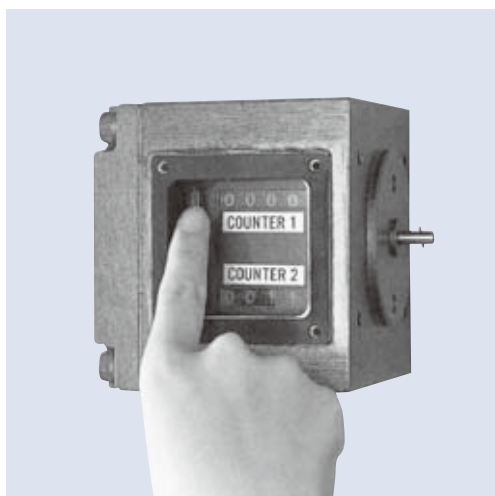

2. Set jack at desired maximum and minimum positions manually or by inching.
3. Press the counter reset button.  
(The display will show 00000 and measure from this position.)
4. Confirm by moving the jack and then returning it to the set position. Limit switch is now activated.



5. Next, set the jack at another position and confirm in the same manner.

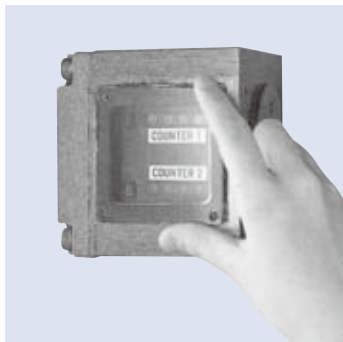
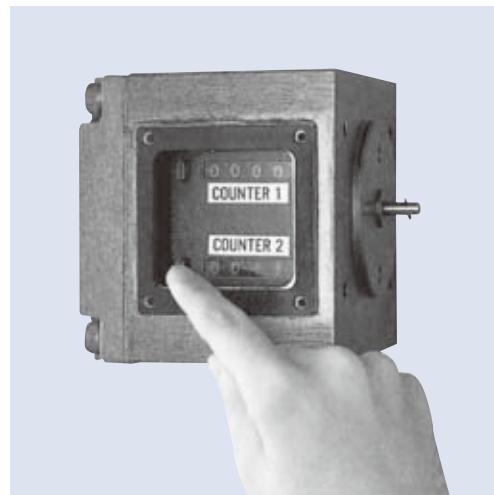

6. Replace cover.

Note) Turning the shaft or travel nut after adjustment will change the setting.

## Position Sensors

3 kinds of position sensors are available.

- ① Internal LS (2 or 4)
- ② Potentiometer
- ③ Rotary Encoder

### ■ Dimensions

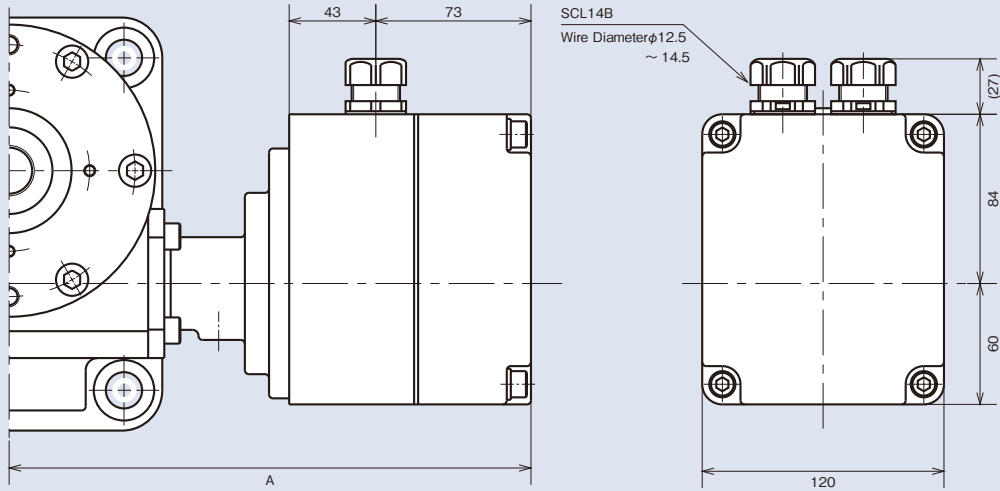

Unit: mm

Frame No.	JWM 002	JWM JWB 005	JWM JWB 010 JWH	JWM JWB 025 JWH	JWM JWB 050 JWH	JWM JWB 100 JWH	JWM JWB 150 JWH	JWM JWB 200 JWH
A	197	197	222	230	255	281	285	290

### ■ Internal Structure - Drawing

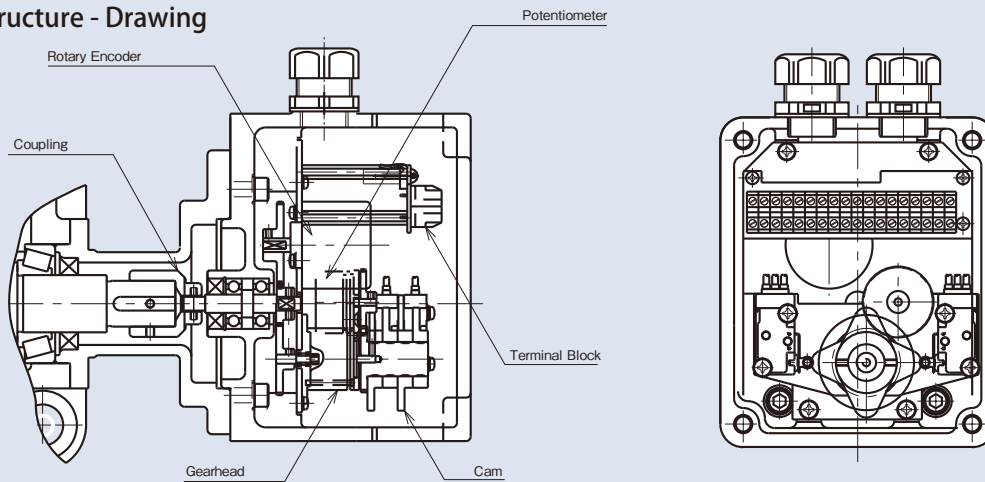

#### Position detection unit wiring

To connect internal LS, potentiometer or rotary encoder, use the terminal block installed in the unit.

Use a shield wire in wiring a rotary encoder.



Terminal No. 1 2 3 4 5 6 7 8 9 10 11 12 13 14 15 16 17 18

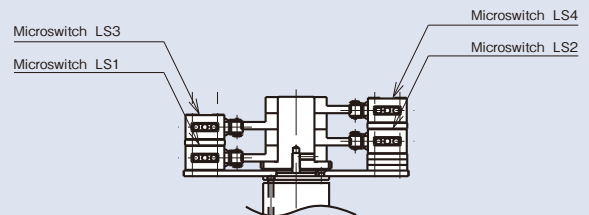

Option	Internal LS (K2,K4)									Potentiometer			Rotary Encoder					
Symbol	LS1		LS2		LS3		LS4		Common	P			R					
Contact	a	b	a	b	a	b	a	b	c	1	2	3	1	2	Z	+5~24V	0V	Case
Terminal No.	18	17	5	6	16	15	7	8	4	1	2	3	9	10	11	12	13	14

## ① Internal LS

- K2……Arrange microswitches LS1 and LS2 as shown below.
- K4……Arrange microswitches LS1, LS2, LS3, LS4 as shown below.

	Option Symbol	Example	
Position Detection Unit Internal LS	K2		Both ends fixed
Position Detection Unit Internal LS	K4		Forward: Fixed at midway position. Fixed end. Return: Fixed at midway position. Fixed end.

Model No.	D2VW-5L2A-1M Equivalent
Electric Composition	250V AC 4A (cosφ0.7)
Contact Composition	1C 

### 〈LS Setting〉

Consider inertia when adjusting LS Cam.

To adjust LS Cam, use a hexagonal wrench and loosen the hexagonal screws (2).

\*LS is not factory adjusted.

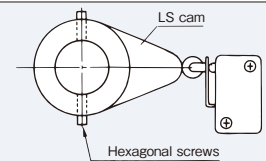

## ② Potentiometer

Potentiometers are programmed to activate within effective angles.

Do not rotate the input shaft before installing the screw shaft to your equipment. This can shift the stroke phase.

Note that the output resistance value varies depending on each frame No. and each stroke.

Total resistance value is 1.0 kΩ, however, depending on the stroke, approximately 1/3 of the total resistance value may be output according to the rotation angle, therefore, confirm it before use.

Model No.	CP-30 Equivalent
Maker	Sakae Tsushin Kougyou
Maximum Resistance	1.0kΩ
Rated Power	0.75W
Dielectric Strength Voltage	1000V AC (1min)
Effective Electrical Angle	355°
Effective Mechanical Angle	360° Endless

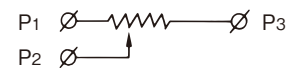

### Potentiometer Control Option 1

#### Stroke Display Meter

Displays stroke in % by receiving signals from the Printed Circuit Board.

Jack models with a potentiometer should be used.

Model No.	RM-80B (100μA DC) Equivalent
Class	JIS C 1102 2.5
Exterior	Black Frame
Scale Used	Maximum Stroke 100%

\* A separate printed board is also required.

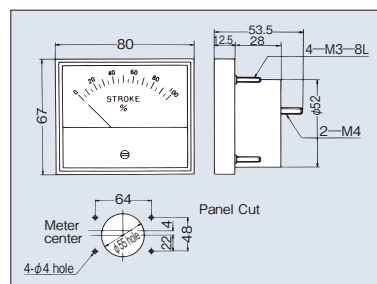

#### Printed Circuit Board

Converts power signals from potentiometer into currents.

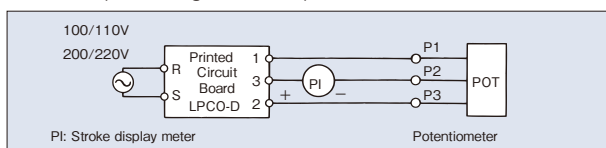

In order to adjust the meter, adjust the volume on the printed circuit board. Do not confuse - and +. When adjusting the meter to 100% while stroke is at MIN, replace the terminal 1.2 of the printed circuit board.

Model no. LPCO-D1 (voltage 100/110V 50/60Hz)  
LPCO-D2 (voltage 200/220V 50/60Hz)

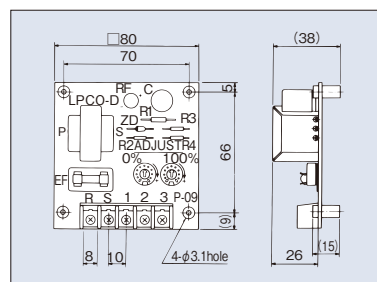

## Potentiometer Control Option 2

### Meter Relay

Easy stroke adjustment is possible using the display panel.

( Standard model comes with a metal panel.  
 Aluminum panels are available upon request. )

Note) For using 4 – 20mA output, designate as "for 4 – 20mA output."

\* A separate printed board is also required.

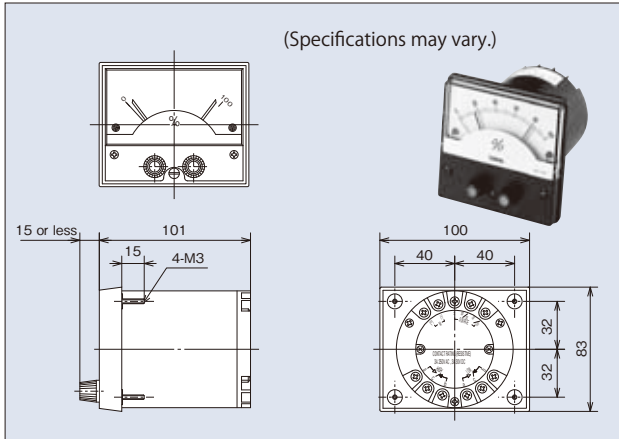

Model No.	NRC-100HL (TSURUGA) or Equivalent
Class	JIS C1102 2.5
Exterior	Black Frame
Scale	Maximum Stroke 100%
Power	100/100V AC 200/220V AC 50/60 Hz
Input	Maximum 100 $\mu$ A DC
Output Contact Composition	High, Low both 1C (see graph below)
Contact Capacity	250V AC 3A ( $\cos \phi = 1$ )

Use Linipower Jack models with a potentiometer. Take caution so that the input shaft does not rotate while the shaft and the potentiometer are not fully connected. This can shift the phase of the stroke.

Once the maximum and minimum stroke positions are roughly set using the LS, use the meter relay thereafter.

### <Relay> (Brake Contact)

Wiring is the same as that for a stroke display meter. However, a separate power source is necessary for the relay. Supply power from the main source used for operation and connect brakes contact in series rather than arranging them in a parallel method.

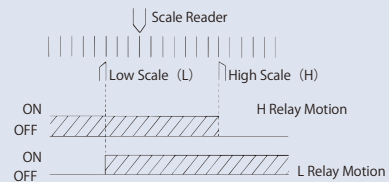



### ③ Rotary Encoder

Rotary encoder specifications	
Model	TS5305N251
Manufacturer	Tamagawa Seiki Co., Ltd.
Output pulse number	600P/R
Output waveform	90° phase difference two-phase square wave + home position output
Output voltage	H — Note 1)
	L 1V or less Note 1)
Power supply	5 to 24V DC

The output signal of the standard specification is of an incremental type, however, an absolute type is also available.

The output type in standard specifications is open collector.

If voltage output type is required, see (Note 1) below.

If the specification of line driver output is required, contact us.

Note 1) Due to the open collector output, output signals are obtained when the pull-up resistor is connected.  
 Signal 1 and signal 2 are output voltages of H "(power supply voltage - 1)V or more" and L "1V or less."  
 For the Z-phase, negative logic applies.  
 <Reference resistance values> 5V: 220Ω, 12V: 470Ω, 24V: 1kΩ

#### Output connection

Signal 1	Signal 2	Signal Z	+5V to 24V	0V	Case
(9)	(10)	(11)	(12)	(13)	(14)

Figures in parentheses indicate terminal No.

#### Output waveform

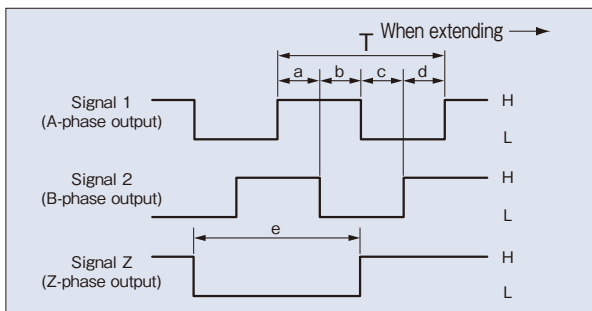

a. b. c. d =  $T/4 \pm T/8$      $T/2 \leq e \leq 3T/2$

#### Output circuit

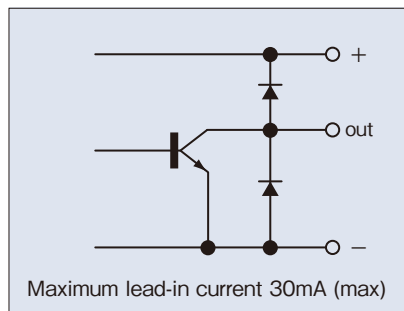

\* Best suited to controlling the stroke by a sequencer or programmable controller, etc.

More accurate positioning control is possible in combination with motor speed control by an inverter, etc.

- ① The standard products incorporate an incremental type encoder.
- ② It has been set to output 300 pulses per revolution of the input shaft.
- ③ It is possible to set an accurate home position of the machine in combination with a limit switch because home position output is read out every 600 pulses.
- ④ Do not apply vibration or impact to the rotary encoder because it is precision equipment.
- ⑤ Use shield wire for wiring to the rotary encoder.
- ⑥ As a guide for the distance between the rotary encoder and control panel, a collector current of 20mA should be able to be transmitted approximately 50m (12V pull-up).

For distances other than the above, consult with us.

# Clevis and Trunnion Mounting Adapters

## 1. Clevis Mounting Adapter

Convenient for use with opening/closing or tilting devices.

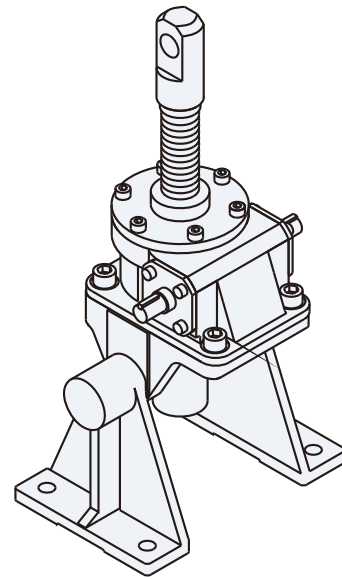
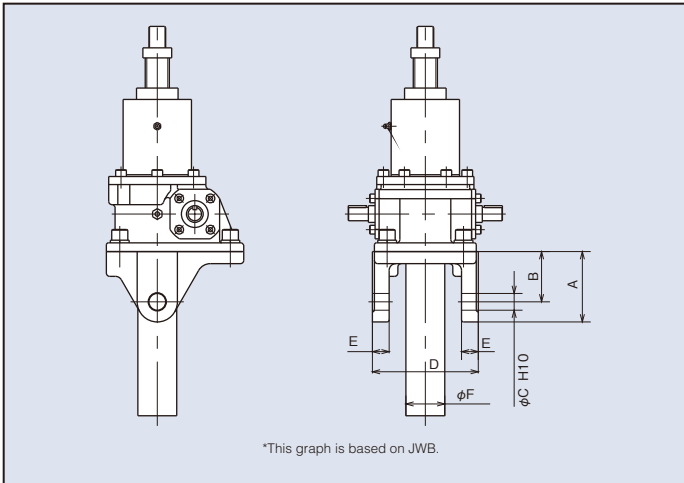

### Clevis Measurements

Unit: mm

Frame No.	A	B	C	D	E	φF
002	75	60	15	64	12	25
005	75	60	15	64	12	25
010	77.5	60	15	86	15	35
025	100	75	20	115	20	45
050	105	75	25	158	25	58
100	145	100	40	201	30	76.3
150	155	105	50	224	44	76.3
200	173	110	63	244	50	89.1

Note) Although standard clevis mounting adapters are for lifting, suspending types are also available.  
 Note) Clevis mounting adapters for rotation prevention are also available in different configurations.

## 2. Trunnion Mounting Adapter

This trunnion mounting adapter is the same as those for power cylinders.

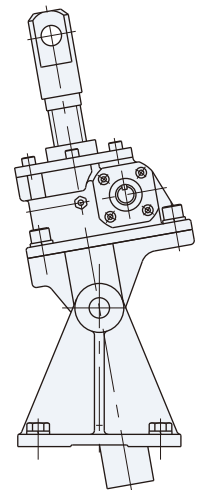
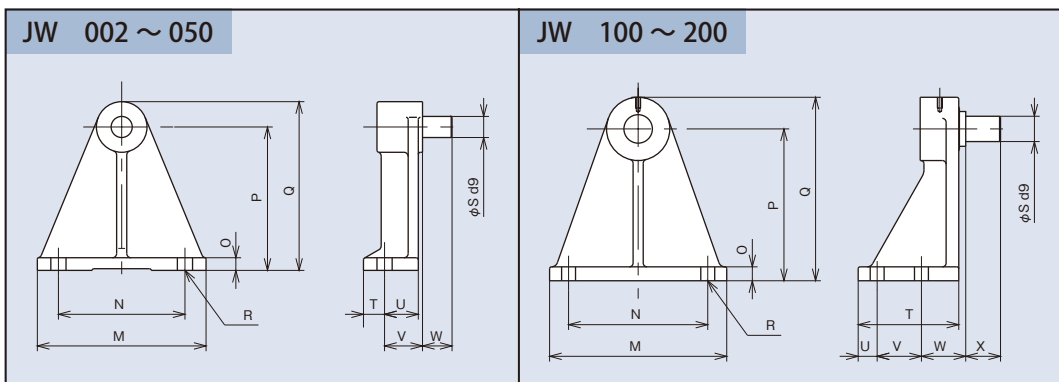

### Trunnion Measurements

Unit: mm

Frame No.	Trunnion Model No.s	M	N	O	P	Q	R	S	T	U	V	W	X
002	LPD300KT-T	130	100	12	100	118.5	2-φ12	15	15	28	30	15	—
005	LPD300KT-T	130	100	12	100	118.5	2-φ12	15	15	28	30	15	—
010	LP500L-T	180	130	15	150	178	2-φ18	15	25	40	45	17	—
025	LPTB1000-T	180	130	15	150	178	2-φ18	20	25	40	45	30	—
050	LPTB2000-T	200	150	15	170	200	2-φ18	25	25	40	45	35	—
100	LPTB6000-T	280	220	22	240	290	4-φ22	40	159	30	70	70	55
150	LPTB12000-T	360	280	27	300	360	4-φ33	50	195	40	85	85	70
200	LPTB16000-T	400	320	30	380	450	4-φ33	63	210	40	90	90	75

# Hand Wheel and Fitting

## 1. Hand Wheel

Hand wheels are available for Linipower Jack so that it can be easily used for manual operation.

Types of hand wheels and applicable jack frame No. are as follows.

Hand wheels are used for self-lock equipped JWM (Machine Screw Type) only.

Hand wheels are not available for JWB (ball screw type) and JWH (high lead ball screw type) because they are not equipped with a self-lock with the result that the input shaft may be reversed by a load, where it is dangerous to use the hand wheel. Hand wheel efficiency is determined by the required torque for a specified load and the diameter of the hand wheel via the following equation.

$$\text{Hand Wheel Efficiency} = \frac{\text{Required Input Torque}}{\text{Hand Wheel Radius}}$$

Hand wheel efficiency equivalent to or below 49N {5kgf} is recommended.

Also, vibration and shock may cause self-lock failure, in which case a brake unit is recommended.

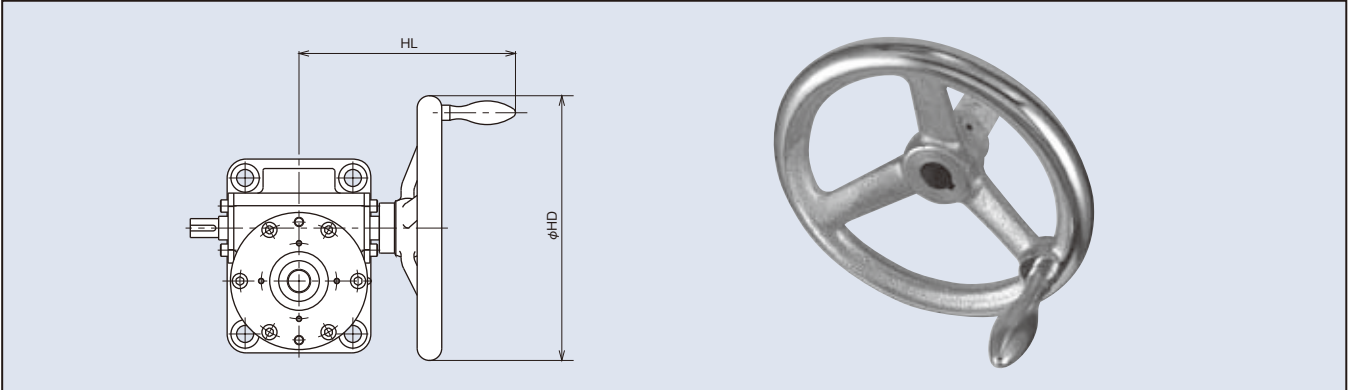

## Hand Wheel Measurements

Example model No. for order placement: JWM010-NV100

Unit: mm

Handle Size Frame No.	NV80-005		NV80-010		NV100-010		NV100-025		NV200-025		NV200-050		NV280-050*		NV280-100*		NV450-100*		
	HD	HL	HD	HL	HD	HL	HD	HL	HD	HL	HD	HL	HD	HL	HD	HL	HD	HL	
JWM002	80	108	—	—	—	—	—	—	—	—	—	—	—	—	—	—	—	—	—
JWM005	80	108	—	—	—	—	—	—	—	—	—	—	—	—	—	—	—	—	—
JWM010	—	—	80	122	100	125	—	—	—	—	—	—	—	—	—	—	—	—	—
JWM025	—	—	—	—	—	—	100	140	200	198	—	—	—	—	—	—	—	—	—
JWM050	—	—	—	—	—	—	—	—	—	—	200	221	280	229	—	—	—	—	—
JWM100	—	—	—	—	—	—	—	—	—	—	—	—	—	—	280	242	450	295	—
JWM150	—	—	—	—	—	—	—	—	—	—	—	—	—	—	280	247	450	300	—
JWM200	—	—	—	—	—	—	—	—	—	—	—	—	—	—	—	—	450	304	—

Note) When using in combination with hand wheels marked with an \* and crevice fitting, trunnion fitting, hand wheel interferes with trunnion fitting. Separately contact TSUBAKI E&M.

## 2. Fitting

This can be used with Open/Close, Reverse Rotation, Positioning and other devices.

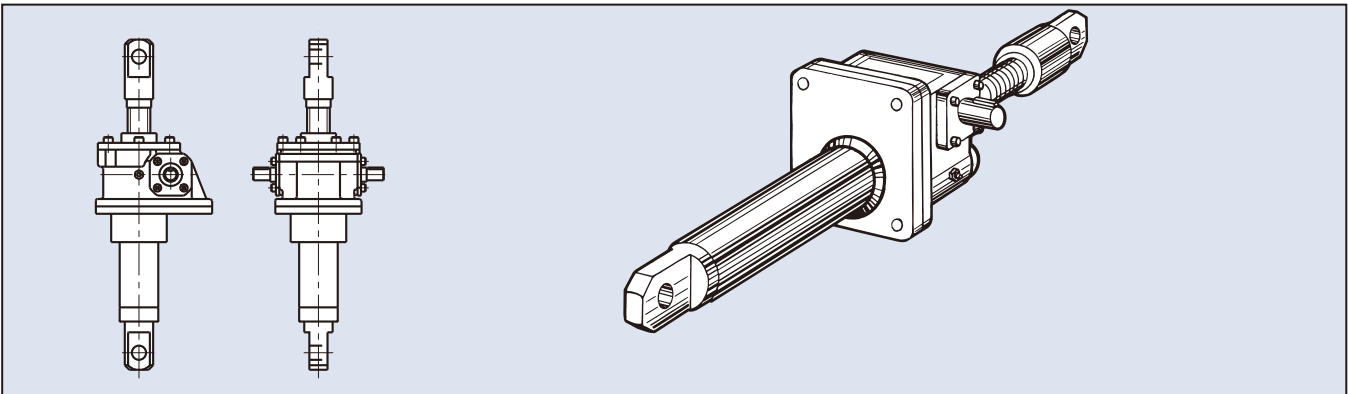

## Safety Cap

The cap is attached to the jack input shaft, on the other side of the motor unit.

By covering the shaft, a safety cap can prevent accidents and even prevent dust generation for clean room operations.

It is compatible with any of the three jack models: JWM (Machine Screw Type), JWB (Ball Screw Type) and JWH (High Lead Ball Screw Type).

Even if the jack body has already been purchased, safety caps can be installed subsequently.

### Cap structure

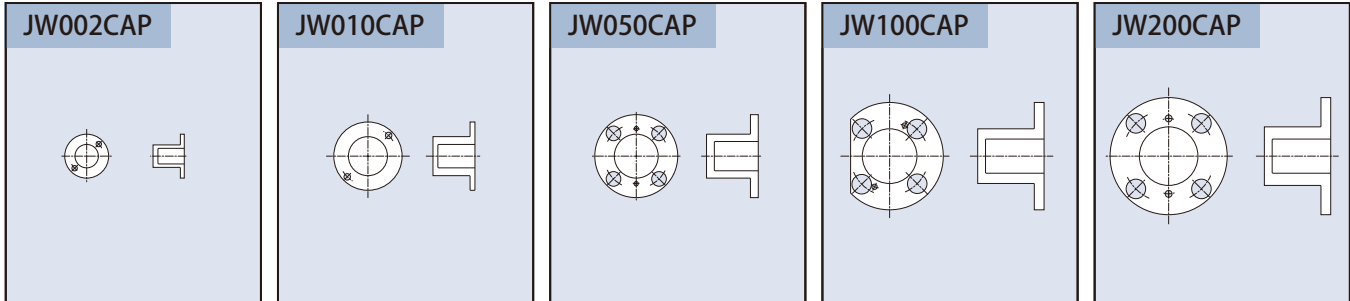

### Dimensional drawing

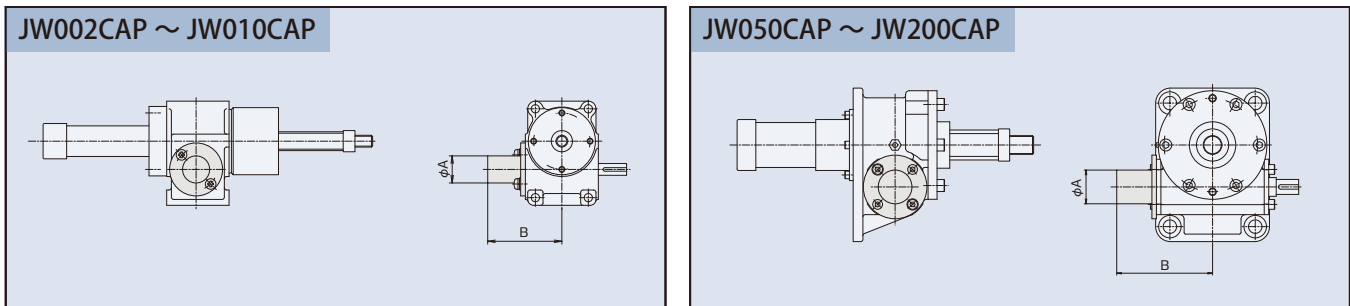

Unit: mm

Safety Cap Model No.	Suitable Jack Model No.	A	B
JW002CAP	JW002	φ22	63
	JW005		
JW010CAP	JW010	φ40	87
	JW025		100
JW050CAP	JW050	φ45	128
JW100CAP	JW100	φ52	155
	JW150		159
JW200CAP	JW200	φ60	163

\*All of the above are in stock. Installation screws are provided.

Material : MC Nylon Color : Black

Safety caps made from other materials are also available.

## Bellows

Use to protect jack components from liquid, chips, dirt, dust and other debris.

### Bellows Below JW010

Sizes below JW010 with bellows are as follows.

Take caution in jack sizing, especially when using for suspension.

Jack Models { JWM002 • 005 • 010  
 JWB005 • 010  
 JWH010

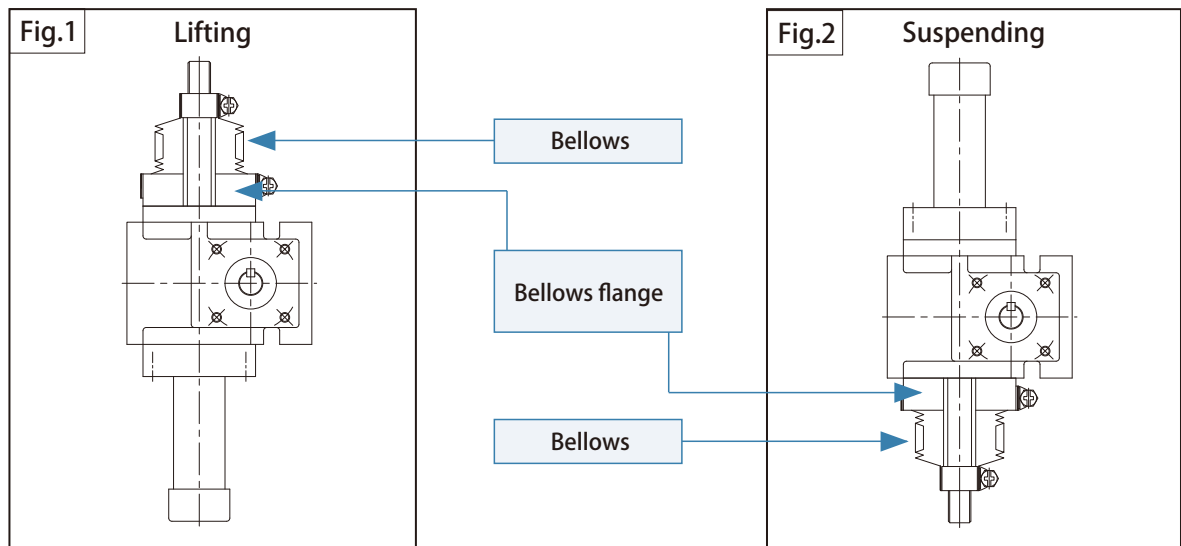

A flange is provided for jacks under JW010 with bellows. When using for suspension, avoid the bellows interfering with machine parts, including the bellows band.

Unit: mm

Frame No.	A	B
JW002	28	42
JW005	28	42
JW010	28	47

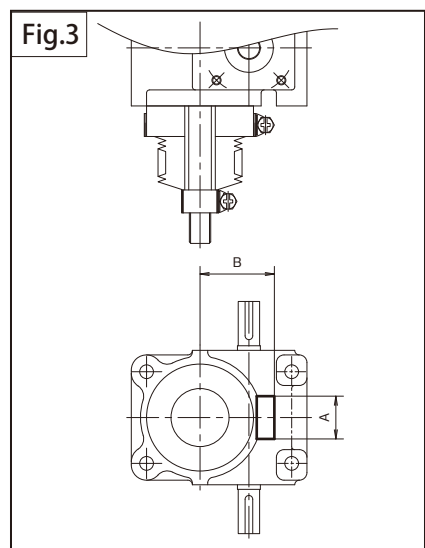

### High Lead Ball Screw

Bellows for High Lead Ball Screw Types are specially designed for specific shaft rpm. Contact TSUBAKI E&M to select the most suitable bellows for your High Lead Ball Screw.

# Bellows Inquiry Form for Travel Nut Type

Select bellows for use with travel nuts based on the diagrams below. Select from band or flange type bellows.

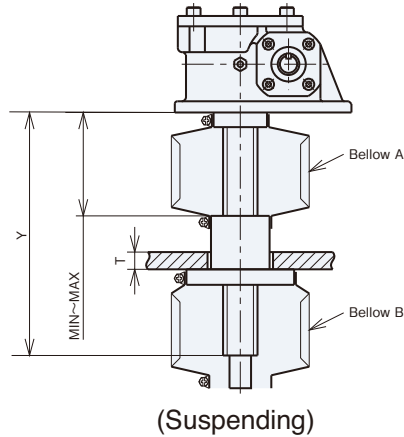
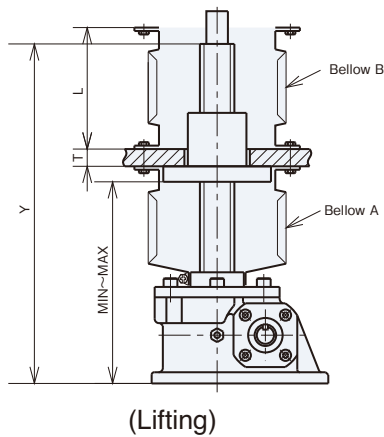

① Jack model No. \_\_\_\_\_

② Actual stroke \_\_\_\_\_ mm  
MIN \_\_\_\_\_ mm ~ MAX \_\_\_\_\_ mm

③ Type of bellows  
Bellows A Band-band, band-flange, flange-flange  
Bellows B Band-band, band-flange, flange-flange

④ Jack screw shaft length limited yes / no  
Y = \_\_\_\_\_ mm

⑧ Bellows L measurements L  
L<sub>MIN</sub> \_\_\_\_\_ mm ~ L<sub>MAX</sub> = \_\_\_\_\_ mm (bellows A)  
L<sub>MIN</sub> \_\_\_\_\_ mm ~ L<sub>MAX</sub> = \_\_\_\_\_ mm (bellows B)

⑤ Base measurements  
T = \_\_\_\_\_ mm

⑨ Bellows attachment opening  $\phi C$   
 $\phi C_{A1}$  = \_\_\_\_\_ mm     $\phi C_{A2}$  = \_\_\_\_\_ mm (bellows A)  
 $\phi C_{B1}$  = \_\_\_\_\_ mm     $\phi C_{B2}$  = \_\_\_\_\_ mm (bellows B)

⑥ Maximum outer diameter of bellow  $\phi J$   
No Limit,  $\phi J_A$  = \_\_\_\_\_ mm     $\phi J_B$  = \_\_\_\_\_ mm

⑦ Flange type and structure (Record only if flange type was selected in ③).

$\phi D_{A1}$ = _____ mm	$\phi d_{A1}$ = _____ mm	bolt mounting part	M <sub>1</sub> = _____ Pcs	$\phi N_1$ = _____ mm	(bellows A)
$\phi D_{A2}$ = _____ mm	$\phi d_{A2}$ = _____ mm	bolt mounting part	M <sub>2</sub> = _____ Pcs	$\phi N_2$ = _____ mm	
$\phi D_{B1}$ = _____ mm	$\phi d_{B1}$ = _____ mm	bolt mounting part	M <sub>1</sub> = _____ Pcs	$\phi N_1$ = _____ mm	(bellows B)
$\phi D_{B2}$ = _____ mm	$\phi d_{B2}$ = _____ mm	bolt mounting part	M <sub>2</sub> = _____ Pcs	$\phi N_2$ = _____ mm	

## ● Bellows Types

### Band - Band Type

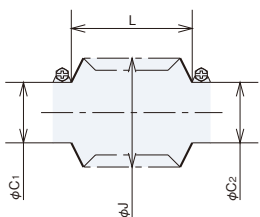

### Band - Flange Type

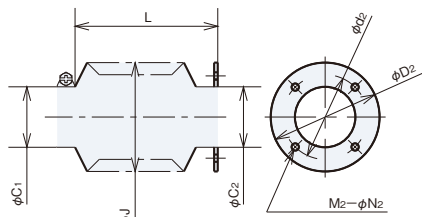

### Flange - Flange Type

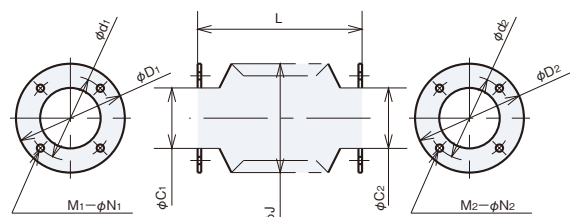

# Notes on Installation

Installation	P251•252
Maintenance and Inspection	P253
General Notes	P254
Glossary	P255



# Installation

## 1. Orientation

Jacks can be installed horizontally, perpendicularly or inclined. Before installing, however, be sure to select the correct (lifting or suspending) jack type.

Since jacks have an open structure, grease or oil separated from grease may splatter or drop. Prepare oil pans or the like. Especially in the case of using a jack for suspending, grease may run down the screw shaft.

## 2. Installation Method

Tighten bolts into the 4 mounting holes in the gear case (mounting bolts are not provided). See Table 1 for bolt sizes. Strength class 8.8 or 10.9 bolts are usually used for mounting. Use 10.9 when load applies directly to the mounting bolts as in Fig. 1.

Table 1. Bolt Sizes

Frame No.	Mounting Hole	Bolt Size
JW002	4-φ7	M6
JW005	4-φ7	M6
JW010	4-φ9	M8
JW025	4-φ11	M10
JW050	4-φ18	M16
JW100	4-φ22	M20
JW150	4-φ22	M20
JW200	4-φ26	M24
JW300	4-φ33	M30
JW500	4-φ42	M39
JW750	4-φ42	M39
JW1000	6-φ42	M39

Fig. 1

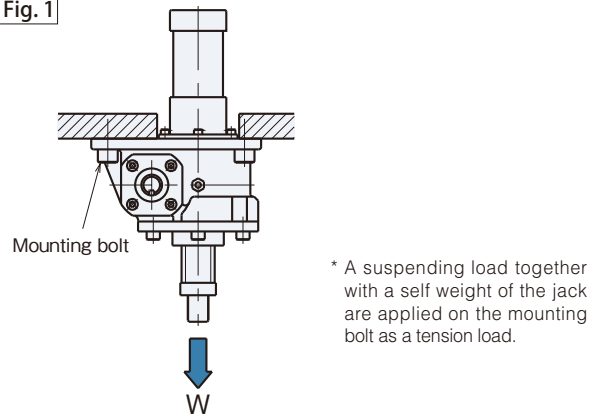

## 3. Installing Motor, Reducer

When installing a motor and reducer unit in addition to the jack body, prepare a robust counter making allowance for a safety factor to prevent alignment accuracy at installation from being reduced even if the maximum load is applied. Make sure that the transmission shaft connected to the input shaft is aligned accurately (Fig.2). Using a floating shaft may result in malfunction due to vibration depending on rotation speed, therefore, sufficiently consider rigidity of the shaft and backlash of the coupling.

Fig. 2

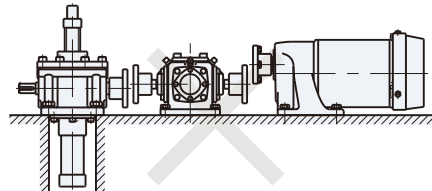

## 4. Rotation Prevention

The jack's thrusting force may cause the screw shaft (nut in the case of ravel nut type) to rotate, in which case a rotation prevention is required. Screw rotation torque at the basic capacity is described in the standard specification list. When operating with the end connected, and pulling the rope or chain with a sheave or sprocket installed, use the rotation prevention type (symbol M).

## 5. Shaft End

Attach shaft end by applying an adhesive agent to its setscrew. It is possible for the shaft end to become detached by the rotational torque applied to the shaft. To avoid this, use one of the following adhesives:

### <Tightening Agents>

Use the following brands or their equivalent.

Read instructions and safety precautions provided with each product before applying.

### Tightening Agents

Maker	Brand
Nihon Lock Tight	# 262, 271
Three Bond	# 1307N

### <Fixing with set screw>

After tightening the end fitting, fix with the attached set screw (hexagon socket head screw) as a locking device.

## 6. Setting the Limit Switch

Consider maximum possible inertia before setting the limit switch. This means calculating the maximum coasting distance affected by specific load and installation conditions. Also, install a mechanical stopper within the stroke range in case of emergencies.

## 7. Setting the Position Detection Unit

An optional position detection unit (internal LS, potentiometer or rotary encoder) is not factory adjusted for its stroke. Make sure to adjust stroke prior to use. Control units such as the potentiometer and rotary encoder generate various signals by measuring the rotation number of the input shaft. Do not allow the screw shaft (nut in the case of the travel nut) to rotate after adjustment because the setting will deviate if the screw shaft is rotated with the input shaft fixed. When adjusting the internal LS, operate the jack manually or by inching with sufficient care so as not to exceed the stroke range of the jack. If the jack exceeds its stroke limit, the screw shaft may fall off or the bellows may be damaged.

## 8. Horizontal use of jack with bellows

When using a jack with bellows in the horizontal direction (including use with swing), the screw shaft may catch the bellows, and damage the bellows, or result in failure of the jack. Please contact TSUBAKI E&M.

## 9. Caution

- ⚠ (1) Jacks that range under the standard capacity of 49.0kN {5tf} are provided with screw covers made of hard vinyl chloride pipe. Never suspend or carry a jack by its cover.
- ⚠ (2) Be certain that the jack rating exceeds the maximum possible stroke. If the stroke capacity is exceeded, the shaft may disengage from the unit or fail to function. Preventative devices for such situations are not provided for JWMs (Machine Screw Type) so over stroke must be avoided. Shaft protection provided for JWBs (Ball Screw Type) and JWHs (High Lead Ball Screw Type) is solely for the purpose of preventing shaft rotation during installation. When installing, be sure that the shaft does not rotate or move. When rotation cannot be avoided, use a rotation prevention type.
- ⚠ (3) Do not operate input shaft manually while loaded. Load pressure will rotate the shaft.
- ⚠ (4) Do not use mechanical stops. This will cause major internal damage.
- (5) Provide oil pans for food manufacturing machines to prevent oil from leaking into food products.
- (6) To install a screw shaft or cover to the base, avoid drilling large holes so as not to reduce the surface area of contact between the jack and the base.
- (7) Apply load in the same direction as that of the screw shaft. Load from inappropriate angles can bend the shaft (Fig. 3). For side load, make sure to use guides so the load or bending momentum do not apply directly to the jack.

Fig. 3

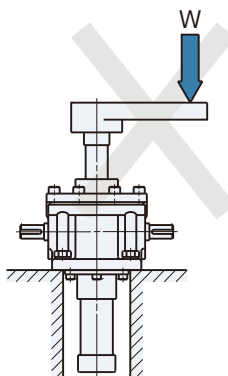

## Maintenance and Inspection

1. Screw shaft and reducer unit are factory greased. See Table 1 for the type of grease used.
2. Regular lubrication intervals for the shaft screw are as recommended in Table 2. For the amount of grease, see Table 3. To regrease, expand the shaft to full stroke, remove old grease and apply using a grease gun or brush. Grease for maintenance is also available. Contact TSUBAKI E&M.
3. Reducer units should be greased based on the lubrication intervals shown in Table 2. However, these intervals may vary depending on operation frequency and conditions. Reducer units of JW025 or greater are provided with grease nipples and hexagon socket head plug. When greasing, remove the hexagon socket head plug and pour grease until grease seeps from the hole for the hexagon socket head plug. After greasing, firmly rewind the seal tape on the hexagon socket head plug to tighten so as to prevent grease from leaking.

Table 1. Recommended Grease

Part	Maker	Grease
Shaft	TSUBAKI E&M	JWGS100G
	Idemitsu	* Daphne Eponex Grease SR No.1
	Nippon Grease	Niglube EP-1K
Reducer Unit	Exxon Mobil	Mobilux EP No.1
	Cosmo Lubricants	Cosmo Grease Dynamax EP No.1
	Showa Shell	Shell Alvania EP Grease 1

\* Factory filled with this grease.

Note) JWGS100G is separately sold in a 100g container. (See page 262.)

Table 2. Lubrication Intervals

Operation Frequency	Lubrication Intervals		
	Machine screw shaft	Ball screw shaft	Reducer unit
50~100/day	1 month	3 months	3 months
10~50/day	3 months	3 months~6 months	3 months~6 months
1~10/day	6 mo.s~1 yr.	6 mo.s~1 yr.	6 mo.s~1 yr.

\* Numerical values described above do not indicate the life of screws and reducer units.

Table 3. Amount of Grease

Frame No.	Application quantity	Initial enclosed quantity
	Shaft (Stroke 100mm)	Reducer Unit
JW002	5g	35g
JW005	5g	35g
JW010	5g	80g
JW025	10~15g	170g
JW050	10~15g	370g
JW100	20~30g	470g
JW150	20~30g	700g
JW200	40~50g	830g
JW300	40~50g	2600g
JW500	50~100g	5500g

4. Grease upper bearings for JWB (Ball Screw Type) and JWH (High Lead Ball Screw Type) using the grease nipple set attached to their housings, at 6-month intervals. Not necessary for jacks JWB/JWH010 and below.
5. Inspect regularly for general backlash and screw unit condition. Jack life and replacement timing are determined by the following:
  - JWM···Backlash in the direction of screw shaft and nut hits 1/4 of the screw pitch.
  - JWB · JWH···Visible particles due to wear and tear of the screw unit.
  - All types···Replace gear when its input shaft exceeds 30 rpm with backlash at H speed, or exceeds 60 rpm at L speed.

 Generally, continuous use without lubrication at recommended intervals may cause inefficiency of shafts and failure of travel nuts.
6. Adjust brake gaps for brake and gearmotors before their gaps reach their maximum capacities. Gap adjustment is not possible for gearmotors with outputs 25W or 40W. For details, see respective instruction manuals.

## General Notes

1. Carefully consider jack ratings before making a selection. Make sure that all anticipated loads, whether static, dynamic or shock, fall within the rated capacity of the jack at reasonable safety levels.
2. Carefully consider the combination of screw shaft rpm and rated load. Also, take extra care in verifying rated buckling load, overhang load and shaft rpm. Exceeding the data provided in this catalog can cause major damage to the system.
3. Confirm that the operating temperature of the jack is within  $-15\sim 80^{\circ}\text{C}$ . To measure, check the surface temperature of input shaft (or nut, if used). Make sure that all rotating parts are completely stopped before proceeding to measure.
4. Do not exceed the maximum rpm of 1800/min.
5. Continuous operation is not possible. Duty cycle at 30 minute intervals for JWM is within 20% ED, JWB and JWH are within 30% ED.

$$\text{Duty cycle (\%ED)} = \frac{1 \text{ Duty cycle}}{1 \text{ Duty cycle} + 1 \text{ Rest cycle}} \times 100\%$$

6. Be sure not to exceed the maximum input torque for multiple jack systems by verifying the rated input torque for each jack.
7. Activating torque should be maintained at 200% above the required torque.
8. If operating in freezing temperatures, a change in viscosity may reduce the efficiency of the grease. Set the drive unit so as to accommodate this change.
- ⚠ 9. Although JWM is equipped with a self-locking device, vibration and shock may affect its efficiency, in which case a brake unit is required. Because of their extremely high efficiencies, JWB and JWH must have sufficient brake units that over power their holding torques.
- ⚠ 10. Evaluate operating environment based on the following:

Location	Indoors where rain and moisture are not present
Room Condition	Dust Volume - Normal
Ambient Temperature	$-15^{\circ}\text{C}$ to $80^{\circ}\text{C}$ (See General Notes No.3)
Relative Humidity	85% or less (no dew condensation)

11. When dust level is high, protect shaft with a bellows.  
 The bellows, which are not water-proof, do not prevent external water from entering and grease in the jack from penetrating to the outside.  
 (For outdoor use, place a cover to protect jack from factors such as rain and wind).

## Glossary

### ① Basic Capacity :

The maximum possible load sustained or lifted by a jack.  
Must be calculated by using the safety rate Sf.

### ② Outer Screw Diameter / Minor Screw Diameter:

As illustrated below.

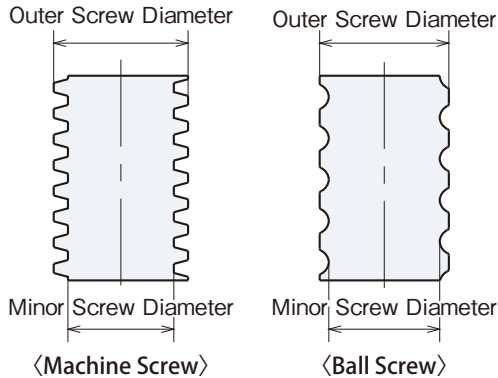

### ③ Screw Lead :

Distance the shaft (or nut, if used) advances in one revolution of worm wheel.

### ④ Stroke :

Possible distance traveled by screw shaft (or nut). Derived from  $X_{MAX} - X_{MIN}$ .

### ⑤ Worm Ratio :

Number of input shaft revolutions required to complete one worm wheel revolution. (Gear ratio of input shaft and worm wheel.)

### ⑥ Overall Efficiency :

Total efficiency of the jack including those of the screw and the worm wheel.

### ⑦ Maximum Allowable Input Capacity :

Input capacity that can regulate the balance between load and screw shaft speed or input rpm.  
Operate within the rated capacity of duty cycle (%ED) and reducer unit surface temperature (max.80°C).

### ⑧ Tare Drag Torque :

Torque required to rotate the input shaft of an unloaded jack.

### ⑨ Holding Torque :

Input torque required for sustaining basic load capacity.

### ⑩ Allowable Input Shaft Torque :

Maximum possible torque allowed for input shaft only. For multiple jack systems, it is the sum of total torque required for synchronous drive, and the actual amount of torque transferred from one jack to another.

### ⑪ Required Input Torque of Basic Capacity :

Input torque required at the input shaft to lift load of basic capacity.

### ⑫ Screw Movement Per Revolution of Input Shaft :

Distance the screw shaft (or nut) advances in one revolution of the input shaft.

### ⑬ Maximum Input rpm for Basic Capacity :

Maximum possible rpm applied to the input shaft to lift load of basic capacity.

### ⑭ Screw Shaft Rotational Torque for Basic Capacity :

Torque generated when the screw (or nut) auto-rotates to lift load of basic capacity. Rotation prevention must be installed either on the machine or the jack to prevent screw and nut from rotating simultaneously.

### ⑮ Rated Load :

Load derived from the maximum allowable input capacity once the input screw shaft rpm is determined.

### ⑯ Buckling :

Buckling is produced when the jack rapidly bends from excessive thrusts. Buckling load varies depending on installation condition and/or position.

### ⑰ Rated Screw Shaft rpm :

Screw shaft may resonate and vibrate when its rpm comes close to the eigen frequency. It is important that the rpm is lower than the resonance point or the rated screw shaft rpm. Must confirm this for travel nut types.

### ⑱ Coasting Distance (Inertia) :

Distance traveled after the motor is switched off. System inertia results in over travel depending on the load, brake size and operation circuit.

### ⑲ Stopping Accuracy :

Range of positions where the screw shaft stops after each operation.

### ⑳ Self-lock :

The ability to maintain load with no brake unit. Self-lock applies to all frame numbers for JWM (Machine Screw Type) 002~1000.

### ㉑ Duty Cycle :

The ratio of run time to total cycle time.

$$\text{Duty cycle (\%ED)} = \frac{1 \text{ Duty cycle}}{1 \text{ Duty cycle} + 1 \text{ Rest cycle}} \times 100 (\%)$$

### ㉒ Thrust :

Power converted from rated torque that is used to lift maximum loads for motored or geared jacks. Motors must be selected carefully when used to run a jack with another motored jack. Also, select thrust for motored jacks with care.

### ㉓ Ball Screw Wear Life :

Ball screw wear life is determined by the distance advanced by the screw nut until the ball "flakes" from friction and fatigue. This distance varies even when operated under similar conditions. If the system runs without this "flaking" of the nut for more than 90% of the time, this is considered B10 or the rated ball screw wear life.

Linipower Jack

# Product Information

Linipower Jack Compact Type	P257~260
Linipower Jack LD Type	P261
Linipower Jack Bevel Gear Type	P262
Mechatro Center	P263•264
Quick Delivery	P265

# Linipower Jack Compact Type

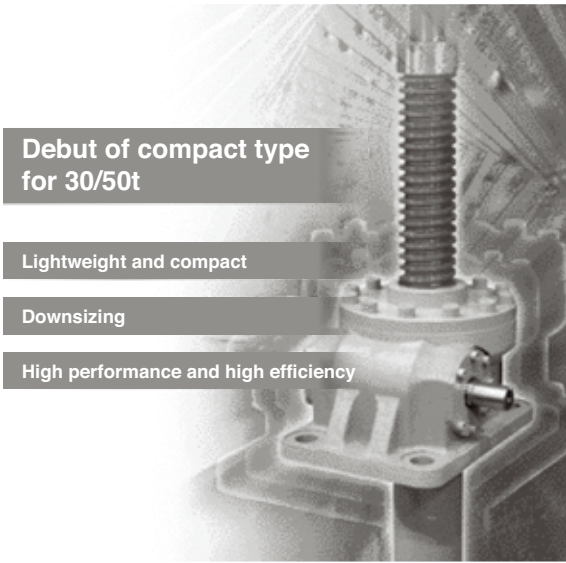

Debut of compact type for 30/50t

Lightweight and compact

Downsizing

High performance and high efficiency

## ● Features

Technology is concentrated in a compact size.  
Best suited for downsizing as it is lightweight and compact.  
High performance and high efficiency

### Comparison with conventional product

Mass ratio (max): 73% (30t type), 85% (50t type)  
Installation area ratio: 77% (30t type), 63% (50t type)

■ Mass ratio

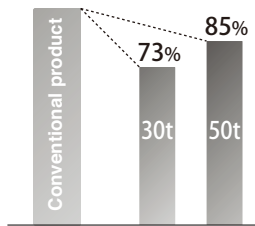

■ Installation area ratio

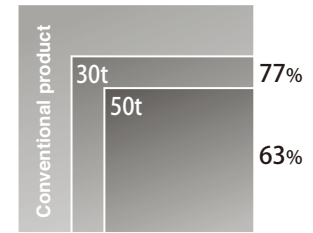

## Model No. designation

# JW M C 300 US H 10 JM - TK

Linipower jack

Compact type

Stroke (mm)

1 : 100  
3 : 300  
6 : 600  
10 : 1000

\* The above shows examples.

Output option

No symbol: Screw shaft end (standard)  
J: Bellows  
B: Rod type end fitting  
I: I-type end fitting  
M: Table type end fitting

Note) Output options are the same as conventional products.  
However, contact us for installation of position detecting unit to 50t type.

Jack type

Basic capacity

Installation type

M: Trapezoidal screw  
B: Ball screw

300: 294kN {30tf}  
500: 490kN {50tf}

US: Standard model for lifting  
DS: Standard model for suspending

Worm gear ratio

Symbol	H	L
Frame No. 300	10 2/3	32
500	10 2/3	32

## Basic specifications list

		JWMC300	JWBC300	JWMC500	JWBC500
Basic capacity	kN {tf}	294 {30}	294 {30}	490 {50}	490 {50}
Major diameter of screw	mm	85	85	120	100
Minor diameter of screw	mm	67	74.8	102	87
Screw lead	mm	16	20	16	24
Worm gear ratio	H	10 2/3	10 2/3	10 2/3	10 2/3
	L	32	32	32	32
Overall efficiency	%				
		H: 20 L: 12	H: 59 L: 37	H: 15 L: 9	H: 59 L: 36
Maximum allowable input capacity	kW				
		H: 6.0 L: 2.8	H: 6.0 L: 2.8	H: 10.6 L: 5.4	H: 11.8 L: 5.1
Drag torque in no-load idling	N·m {kgf·m}	9.8 {1}		19.6 {2}	

		JWMC300	JWBC300	JWMC500	JWBC500
Allowable input shaft torque *1	N·m {kgf·m}	735.0 {75}		912.0 {93}	
Required input torque for basic capacity *2	N·m {kgf·m}				
		H: 361.0 {36.8}	L: 159.0 {16.2}	H: 800.0 {81.6}	L: 318.0 {32.4}
Screw movement per revolution of input shaft	mm				
		H: 1.50 L: 0.50	H: 1.88 L: 0.63	H: 1.50 L: 0.50	H: 2.25 L: 0.75
Maximum input rpm for basic capacity	r/min				
		H: 160 L: 140	H: 380 L: 340	H: 130 L: 120	H: 380 L: 300

\*1 The allowable torque is for a jack input shaft only. (Reconfirm for linkage operation.)

\*2 The values include drag torque in no-load idling.



## Screw shaft speed (elevation speed) and allowable load related graphs

These graphs show the relationship between screw shaft speed and allowable load. Since these graphs have been prepared in consideration of the maximum allowable input capacity of each jack frame No., check the allowable load with these graphs to determine the frame No.

If detailed consideration is required, confirm by calculation (page 149).

### JWMC (trapezoidal screw type)

#### ■ H speed

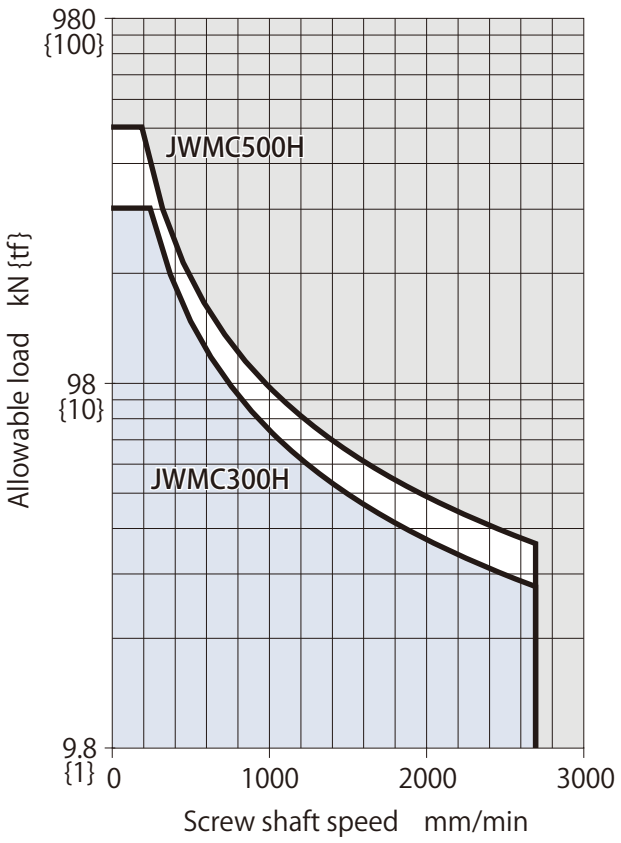

#### ■ L speed

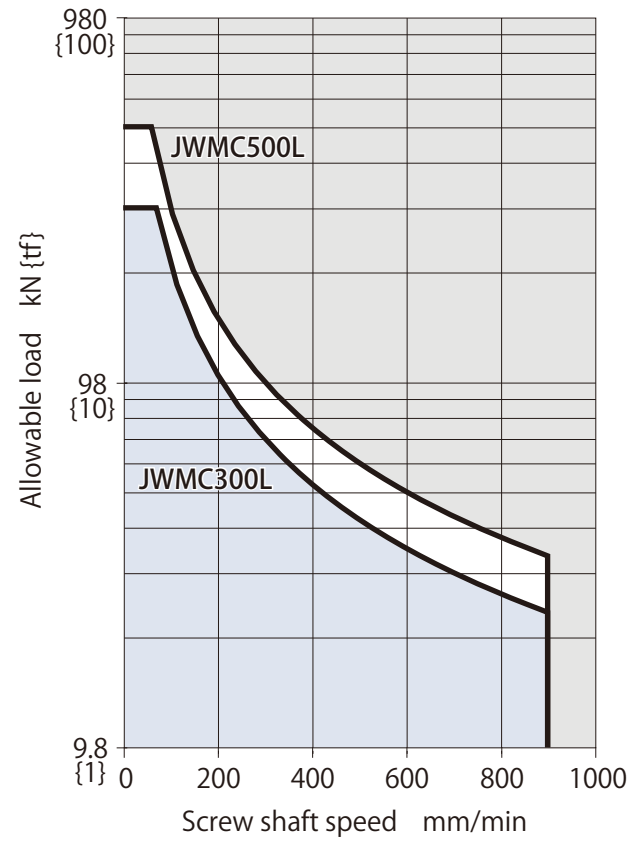

### JWBC (ball screw type)

#### ■ H speed

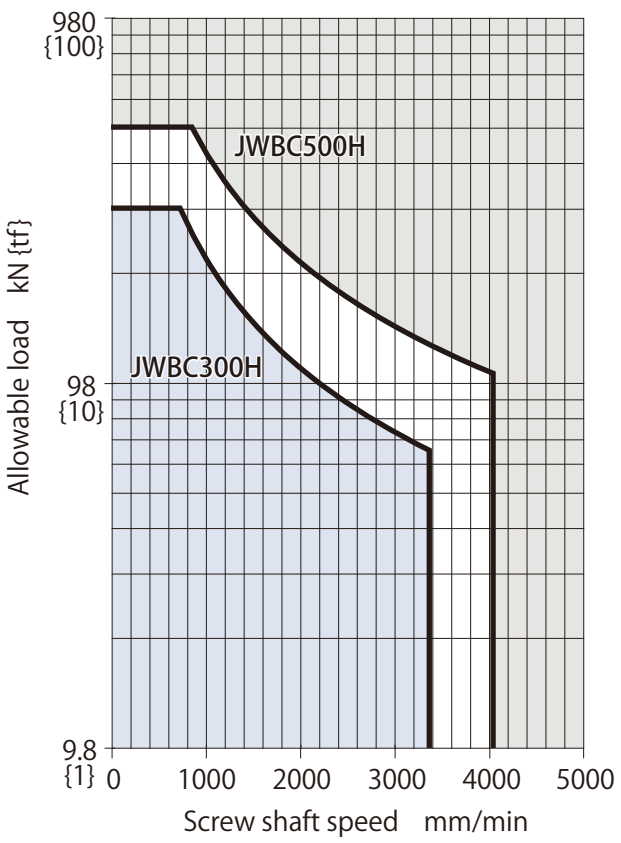

#### ■ L speed

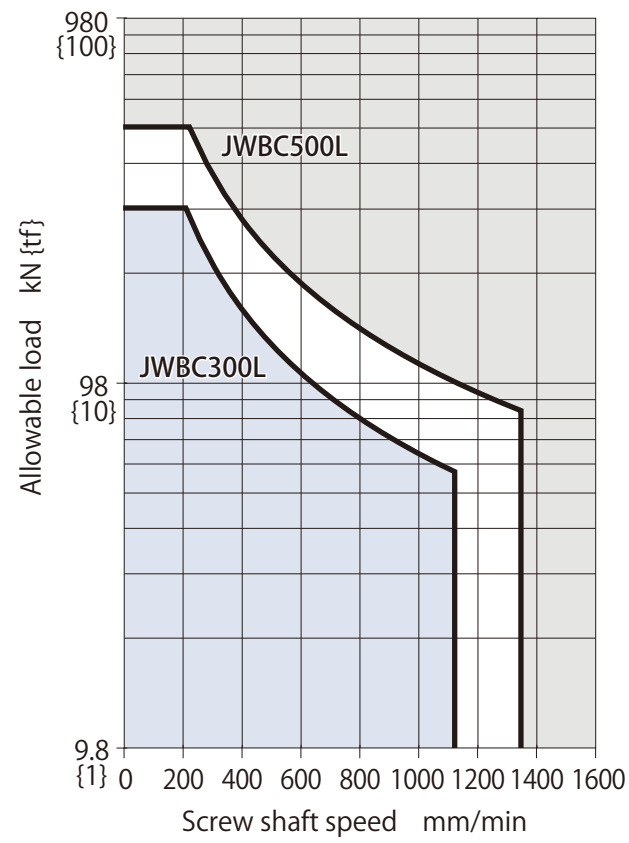

## Allowable buckling load

- For use with compression loads, determine the jack frame No. with respect to buckling load from these graphs. The buckling selection graphs assume the safety rate  $S_f=4$ .
  - ① From the installation conditions A and C shown below, select stroke distances  $L_A$  and  $L_C$ . (For installation conditions other than the following, see page 160.)
  - ② Select a jack frame No. from the intersection point of the load  $W$  (vertical shaft) and stroke distance (horizontal shaft) per jack.
- Lateral load should not be applied. No lateral load is considered in the following buckling selection graphs.
- In an installed condition, if the equipment is devised so that the screw shaft becomes a tensile load, it will be economical having no buckling.

### A Fixed base – Shaft end free

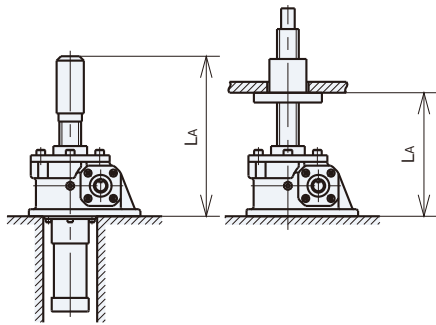

### C Fixed base – Guided shaft end/Fixed shaft end

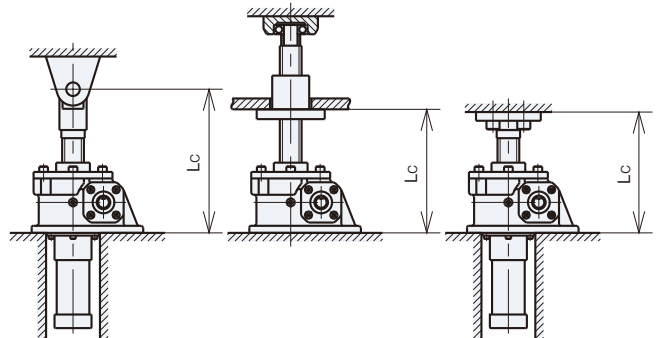

### JWMC (trapezoidal screw type)

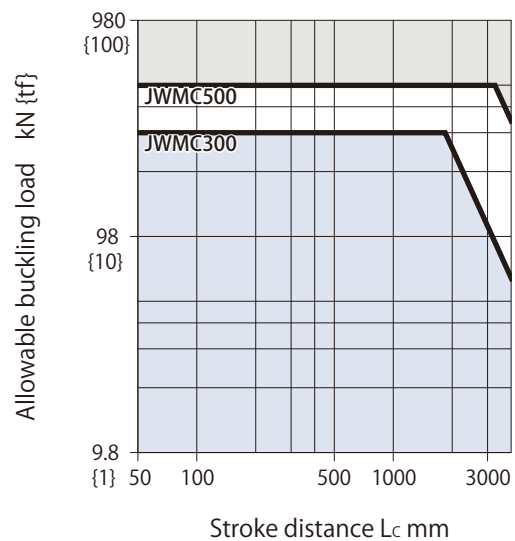
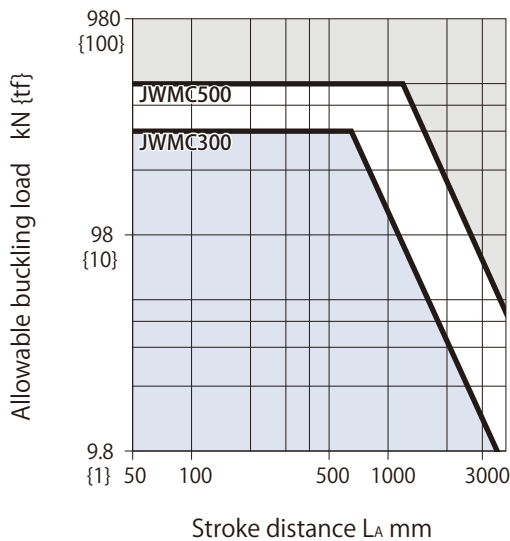

### JWBC (ボールネジタイプ)

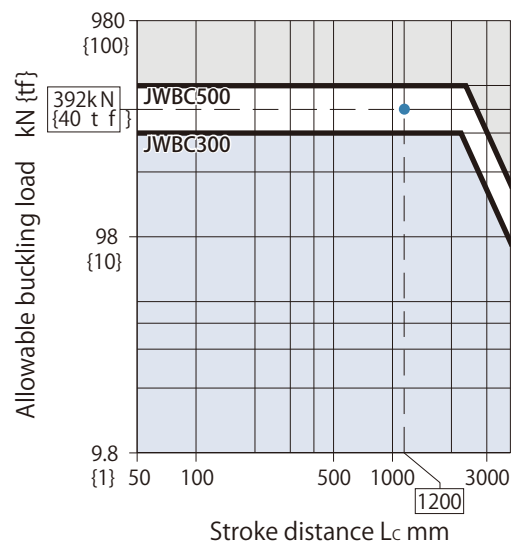
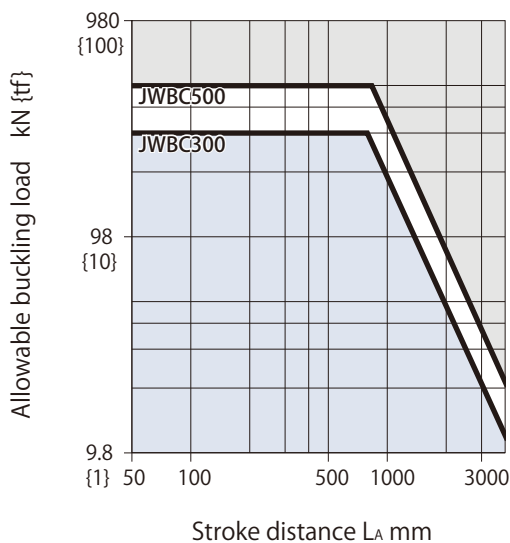

Note)1. The dotted lines on the above graph show an example in which the load is  $W_{392\text{kN}}$   $\{40\text{tf}\}$  and the stroke distance is 1200mm in the installation condition C with the buckling safety rate  $S_f=4$ . In this case, jack JWBC500 that satisfies the intersection point of the vertical axis and horizontal axis can be selected.

2. If detailed consideration is required, confirm by calculation (page 160).

Dimensions table; trapezoidal screw type

**JWMC300**

**For lifting**

**For suspending**

Stroke	US standard model for lifting					DS standard model for suspending					Approximate mass kg
	X		X		L	X		X		L	
	Without bellows	With bellows	Without bellows	With bellows		Without bellows	With bellows	Without bellows	With bellows		
MIN	MAX	MIN	MAX		MIN	MAX	MIN	MAX			
100	255	355	265	365	135	55	155	65	165	135	86
200	255	455	265	465	235	55	255	65	265	235	92
300	255	555	280	580	350	55	355	80	380	350	97
400	255	655	280	680	450	55	455	80	480	450	102
500	255	755	295	795	565	55	555	95	595	565	108
600	255	855	295	895	665	55	655	95	695	665	113
800	255	1055	310	1110	880	55	855	110	910	880	124
1000	255	1255	330	1330	1100	55	1055	130	1130	1100	136
1200	255	1455	340	1540	1310	55	1255	140	1340	1310	146
1500	255	1755	365	1865	1635	55	1555	165	1665	1635	163
2000	255	2255	400	2400	2170	55	2055	200	2200	2170	190

**JWMC500**

**For lifting**

**For suspending**

Stroke	US standard model for lifting					DS standard model for suspending					Approximate mass kg
	X		X		L	X		X		L	
	Without bellows	With bellows	Without bellows	With bellows		Without bellows	With bellows	Without bellows	With bellows		
MIN	MAX	MIN	MAX		MIN	MAX	MIN	MAX			
100	310	410	315	415	137	55	155	60	160	137	211
200	310	510	315	515	237	55	255	60	260	237	222
300	310	610	335	635	357	55	355	80	380	357	236
400	310	710	335	735	457	55	455	80	480	457	247
500	310	810	345	845	567	55	555	90	590	567	259
600	310	910	345	945	667	55	655	90	690	667	271
800	310	1110	360	1160	887	55	855	105	905	887	295
1000	310	1310	375	1375	1097	55	1055	120	1120	1097	320
1200	310	1510	385	1585	1307	55	1255	130	1330	1307	344
1500	310	1810	405	1905	1627	55	1555	150	1650	1627	379
2000	310	2310	440	2440	2167	55	2055	185	2185	2167	440

Dimensions table; Ball screw type

**JWBC300**

**For lifting**

**For suspending**

Stroke	US standard model for lifting					DS standard model for suspending					Approximate mass kg
	X		X		L	X		X		L	
	Without bellows	With bellows	Without bellows	With bellows		Without bellows	With bellows	Without bellows	With bellows		
MIN	MAX	MIN	MAX		MIN	MAX	MIN	MAX			
100	495	595	505	605	168	77	177	87	187	146	132
200	495	695	505	705	268	77	277	87	287	246	138
300	495	795	520	820	383	77	377	102	402	361	145
400	495	895	520	920	483	77	477	102	502	461	151
500	495	995	535	1035	598	77	577	117	617	576	157
600	495	1095	535	1135	698	77	677	117	717	676	163
800	495	1295	550	1350	913	77	877	132	932	891	176
1000	495	1495	570	1570	1133	77	1077	152	1152	1111	189
1200	495	1695	580	1780	1343	77	1277	162	1362	1321	205
1500	495	1995	605	2105	1668	77	1577	187	1687	1644	221
2000	495	2495	640	2640	2203	77	2077	222	2222	2181	253

**JWBC500**

**For lifting**

**For suspending**

Stroke	US standard model for lifting					DS standard model for suspending					Approximate mass kg
	X		X		L	X		X		L	
	Without bellows	With bellows	Without bellows	With bellows		Without bellows	With bellows	Without bellows	With bellows		
MIN	MAX	MIN	MAX		MIN	MAX	MIN	MAX			
100	580	680	585	685	172	87	187	92	192	140	280
200	580	780	585	785	272	87	287	92	292	240	289
300	580	880	605	905	392	87	387	112	412	360	300
400	580	980	605	1005	492	87	487	112	512	460	309
500	580	1080	615	1115	602	87	587	122	622	570	319
600	580	1180	615	1215	702	87	687	122	722	670	328
800	580	1380	630	1430	917	87	887	137	937	885	348
1000	580	1580	645	1645	1132	87	1087	152	1152	1100	368
1200	580	1780	655	1855	1342	87	1287	162	1362	1310	386
1500	580	2080	675	2175	1662	87	1587	182	1682	1630	415
2000	580	2580	710	2710	2197	87	2087	217	2217	2165	464

## Linipower Jack LD Type

Excellent choice for clean room systems such as FDP (Liquid Crystal/PDP). This model regulates dust generation caused by wear as well as rust produced from the screw. Factory tested for dust volume, it is highly reliable for clean room operations.

### 1. Basic Specifications

**RAYDENT® Treatment on the screw shaft** Rust prevention

**Feature 1** Special anti-rust element is processed into the surface of the screw shaft.  
\* RAYDENT® Treatment is a registered trademark of RAYDENT INDUSTRIAL CO., LTD.

**Grease for clean room applied to the screw shaft** Dust prevention

**Feature 2** Special grease for clean room is factory applied to screw shafts. This grease is effective in preventing dusting.

**Urethane resin painting** Cleanliness

**Feature 3** Urethane resin painting is applied to the jack housing. The painting itself is peel-resistant, and its glossy appearance offers a clean look.

### 2. Dust Emission Comparison Graphs (Our test results)

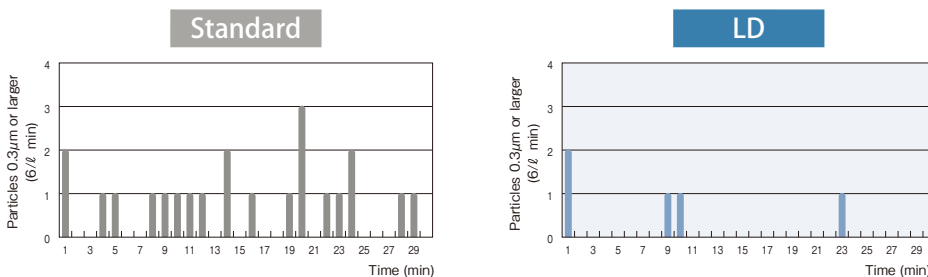

#### [Test Conditions]

Heading	Contents
Frame no.	JWBO25URH5D (Travel nut type)
Speed	40mm/s (Fixed nut, lift/lower repetition, no load)
Location	Clean Room Clean Bench
Portion	Bottom of screw
Equipment	Laser Dust Monitor
Flow	6 l /min
Measured dia. of particles	0.3 µm and larger

\* The above data is based on dust emitted from the screw portion. Use a safety cap to prevent dust from the oil seal in the input shaft portion. Dust is collected in this cap and prevented from entering into the atmosphere.

### 3. Options

The following options are available with Linipower Jack LD Type:  
 (Select according to specific requirements)

- Input shaft.....Electroless nickel plating
- End fitting.....Electroless nickel plating
- Steel pipe.....Metallic screw cover
- Safety cap.....Plastic
- Ball nut.....RAYDENT® treatment.

## Linipower Jack Bevel Gear Type

Bevel gear type released in response to voices demanding high speed and high frequency operation.

### 1. Basic Specifications

**Higher speed is realized by combination with high lead ball screw.** High speed

**Adoption of bevel gear in reducer unit allows for high speed and high frequency operation.** High frequency

**Easy installation by unitization. Assembly man-hours are also reduced.** Reduction in assembly man-hours

**Optimum for use in clean rooms in combination with LD (low dusting) specification.**  
This photo shows bevel gear type LD specification. (Option mounted product)

## Lubrication Grease for Power Cylinder Linipower Jack

**TSUBAKI E&M**  
**Low dusting grease for screw shaft**  
**LD grease**

**Effective for use in clean rooms!**

Model No.: JWGC100G



**TSUBAKI E&M screw shaft**  
**lubrication grease**

**Effective for use in clean rooms!**

Model No.: JWGS100G



## Linipower jack screw set on sale

Sets of screw shafts and nuts for linipower jacks are on sale. For screw specifications (screw diameter and screw lead), see the following pages.

- |                   |                 |
|-------------------|-----------------|
| Trapezoidal screw | P169~170 (~φ85) |
| Ball screw        | P195~196 (~φ85) |

**For use and selection set with coupling and reducer, please feel free to consult with us.**



Technical Notes

JWM

JWB

JWH

Options

Installation Precautions

Product Information

Inquiry Form

# Selection service

## ● Service contents

An optimum jack linkage system is offered according to customer application. Selection of drive part and peripheral equipment, preparation of layout drawing, etc., are flexibly handled.

### Selecting calculation

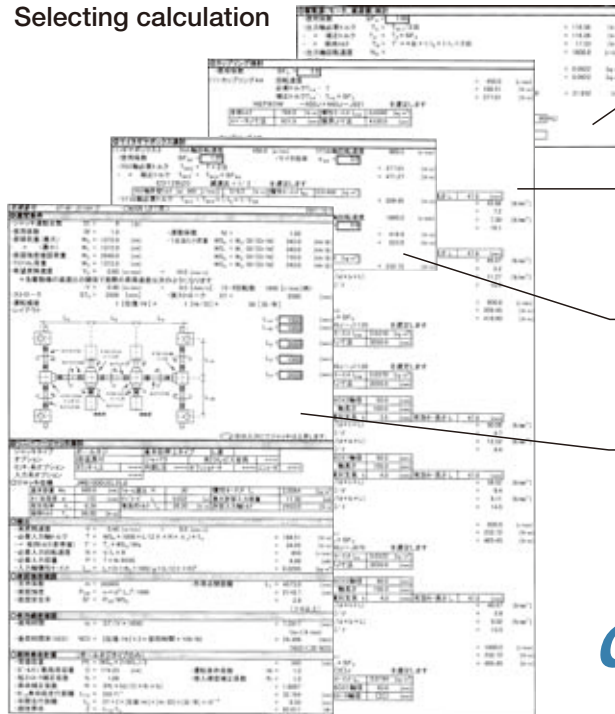

Selection of drive source  
 · Type  
 · Characteristics  
 · Torque

Selection of coupling  
 · Size  
 · Length  
 · Shaft diameter

Selection of gearbox  
 · Capacity  
 · Gear ratio  
 · Shaft arrangement

Selection of jack  
 · Model No.  
 · Buckling  
 · Life

*Quick response!*

*To improve design efficiency!*

Preparation of layout drawing

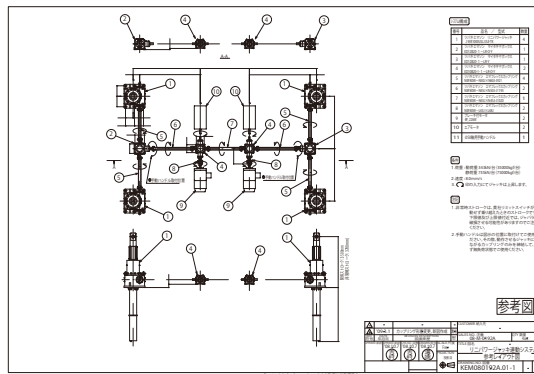

## [Reducers]

### Gearmotor

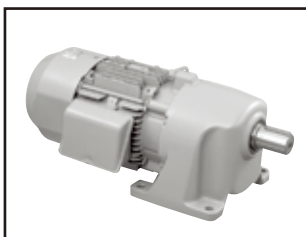

- Low noise, compact, light
- 0.1~5.5 kW  
Gear ratio 1/5~1/1200
- Unique face mount (standard)
- Quiet, high performance brake.

### Hypoid Motor



- Space saver
- 0.1~5.5kW  
Gear ratio 1/5~1/1200
- Face or foot mounting and hollow shaft (all standard).
- Quiet, high performance brake.



Cosult with Mechatronics Center

TEL : +81-790-47-1801 FAX : +81-790-47-1939

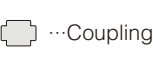
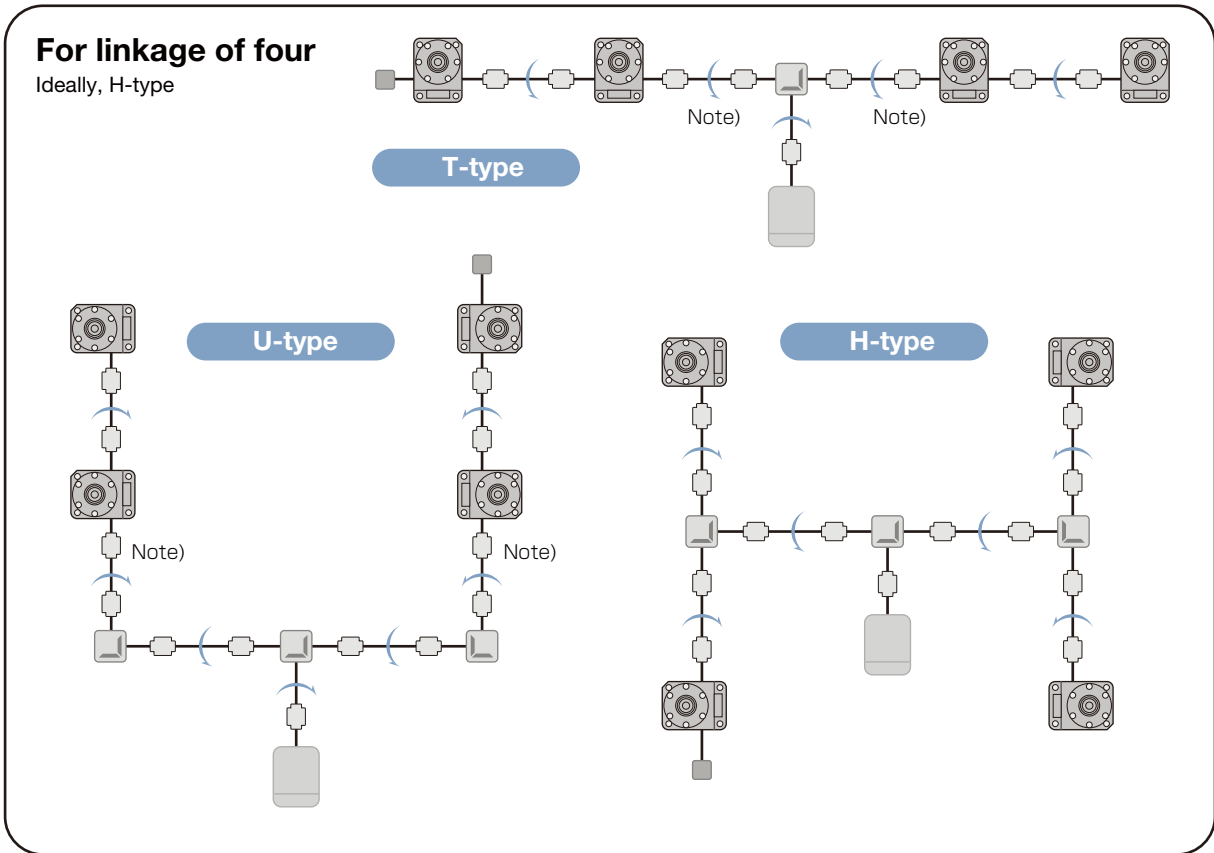
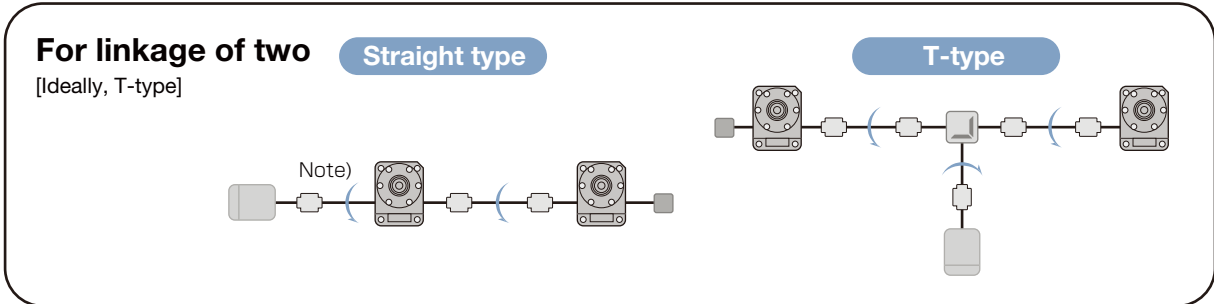

Jack's lift as rotational input is applied in the direction of each arrow.  
Note) Consider allowable input torque when driving in series.

## [Gear Boxes]

### Miter Gear Box

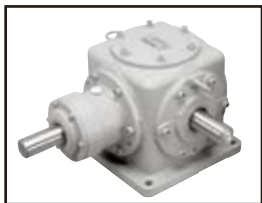

- Gear ratio 1 : 1 size 10
- Gear ratio 1.5 : 1 size 5
- Gear ratio 2 : 1 size 9
- Gear ratio 2.5 : 1 size 5
- Gear ratio 3 : 1 size 5
- Enhanced performance by new AGMA standards.
- Wide variation of models.
- High reliability

## [Coupling]

### ECHT-FLEX coupling

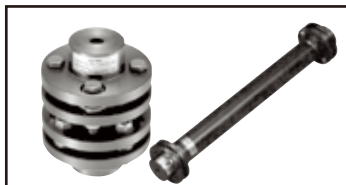

- Torque range : 2.9~176400 N·m
- Bore diameter range : 5~289 mm
- No backlash, high efficiency and servo motor compatible.
- Requires less maintenance, no lubrication and long life.
- Long Spacer Types requiring no bearings available.

### Jaw Flex Coupling



- Compact, light
- Simple
- Easy to un/install

Ask TSUBAKI E&M for other protecting devices such as shock relays, torque limiters, and torque guards.



# SAVE YOUR TIME!!

That is our promise.

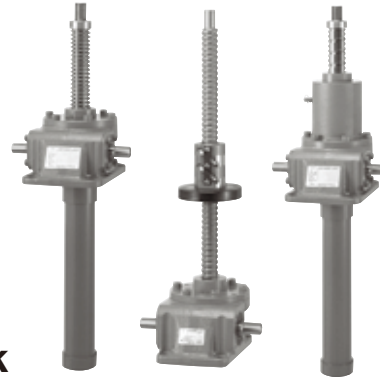
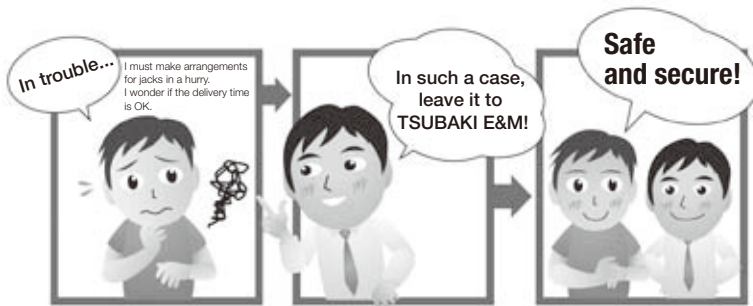

## Delivery chart for standard Linipower Jack

	Type	Installation type	Basic Capacity	Stroke (mm)	Delivery
Standard Model	JWM (Machine Screw Type)	US DS	002	100~400	<b>5</b> days
	JWB (Ball Screw Type)		005~200	100~600	
	JWH (High Lead Ball Screw Type)		010~200	100~600	
Rotation Prevention Type	JWM (Machine Screw Type)	UM DM	002	100~400	<b>1</b> week
	JWB (Ball Screw Type)		005~050	100~600	
	JWB (Ball Screw Type)		005~050	100~600	
Travel Nut Type	JWM (Machine Screw Type)	UR DR	002	100~400	<b>1</b> week
	JWB (Ball Screw Type)		005~200	100~600	
	JWB (Ball Screw Type)		005~200	100~600	
Compact Jack Type	JWMC (Machine Screw Type)	US DS	300~500	100~1000	<b>2</b> months
	JWBC (Ball Screw Type)				

\* Contact us for a lot of 5 units or more regarding the above.

# *Inquiry Form*

# Power Cylinder Inquiry Form

Inform TSUBAKI E&M of the following items when making an inquiry.

Company name: \_\_\_\_\_

Your name: \_\_\_\_\_

TEL : \_\_\_\_\_

FAX : \_\_\_\_\_

(〒       -       )

Address: \_\_\_\_\_

Standard Specification	1. Application load (thrust)	Normal operation	N{kgf}	Max	N{kgf}
	2. Speed	mm/s (at 50Hz, 60Hz)			
	3. Stroke	Actual stroke	mm	Max stroke	mm
Electric Motor	4. Power	3-phase 200V/50Hz, 200V/60Hz, 220V/60Hz 3-phase 400V/50Hz, 400V/60Hz, 440V/60Hz			Others
	5. Special Specification	Brake,      Outdoors,      Explosion-proof			Others
Operating Environment	6. Operation	times/min x	min/hrs. x	hrs./day x	days/yr.
	(Back and forth count as 2)				
	7. Ambient Temperature	°C			
	8. Mounting Location	Indoor,      Outdoors,      Explosion-proof			Others
	9. Dust	Average,      High			
	10. Control Device	Stroke adjustment external LS,      Thrust detection LS, Internal LS,      Potentiometer,      Rotary Encoder			Others
11. Others	Trunnion fitting, crevice fitting, I-shape end fitting			Others	

Layout    Other information

## Servo Type Inquiry Form

Inform TSUBAKI E&M of the following items when making an inquiry.

Company name: \_\_\_\_\_ Your name: \_\_\_\_\_

TEL : \_\_\_\_\_ FAX : \_\_\_\_\_

( 〒                      -                      )

Address: \_\_\_\_\_

**[Equipment standard condition]** Description of equipment used

Type and property of load	<input type="checkbox"/> Horizontal <input type="checkbox"/> lift <input type="checkbox"/> suspension <input type="checkbox"/> tilt <input type="checkbox"/> others extent of shock, inertia and vibration <input type="checkbox"/> Small <input type="checkbox"/> Middle <input type="checkbox"/> Large			
Transfer mass	kg	kg		
Necessary thrust	Normal operation	N (kgf)	Max.	N (kgf)
Speed	Normal operation	mm/s	Max.	mm/s
Stroke	Normal operation	mm	Max.	mm
Operating frequency <small>(Back and forth count as 2)</small>	times/min x	min/hrs. x	hrs./day x	days/yr.
Power cylinder expected life	(                      ) years operating schedule			

**[Power cylinder operation cycle]**

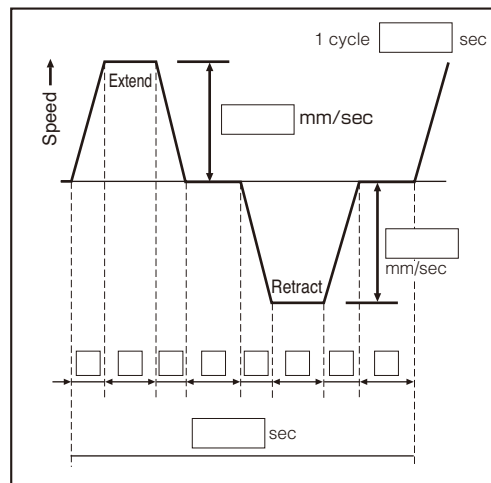

**[Servomotor used]**

Servomotor manufacturer		Servomotor model No.	
-------------------------	--	----------------------	--

**[Other conditions]**

Operating Environment	Ambient temperature	°C
	Installing place	<input type="checkbox"/> Indoor <input type="checkbox"/> Others (                      )
	Dust	<input type="checkbox"/> Nearly average <input type="checkbox"/> Others (                      )
	Power source	<input type="checkbox"/> 3-phase 200/200 220V AC 50/60/60Hz <input type="checkbox"/> Others (                      )
	Others	<input type="checkbox"/> Trunnion fitting <input type="checkbox"/> U-shape fitting <input type="checkbox"/> Magnetic sensor <input type="checkbox"/> Bellows <input type="checkbox"/> Others (                      )

Layout    Other information

# Linipower Jack Inquiry Form

Inform TSUBAKI E&M of the following items when making an inquiry.

Company name: \_\_\_\_\_

Your name: \_\_\_\_\_

TEL : \_\_\_\_\_

FAX : \_\_\_\_\_

(〒       -       )

Address: \_\_\_\_\_

Operating condition	Equipment or Load Condition	Equip. Description _____ • No Shock • Moderate Shock • Severe Shock Light Load • Medium Load • Heavy Load
	Overall Equip. Weight/No.of Jacks	Equip. Max load _____ kN { _____ tf}/Jack (Equip. Min. load _____ kN { _____ tf}/Jack)
	Installation form	Standard specification (Lift/Suspend) With/Without Rotation prevention Travel Nut (Lift/Suspend)
	Installation Condition (Buckling Safety Rate Sf)	A. Fixed Base Shaft end free B. Crevice-Both End C. Fixed Base Fixed Shaft End (Sf= _____ ) Leave open if no buckling load applies to screw shaft.
	Screw Type	Machine Screw Type Ball Screw Type High Lead Screw Type

Three specifications	1. Load Requirement	Load /Jack based on the above the information _____ kN { _____ tf}
	2. Speed	_____ ~ _____ mm/s ( _____ ~ _____ mm/min)
	3. Stroke	Actual Stroke _____ mm Max. stroke _____ mm

Operating condition	Operation	_____ times/min x _____ min/hrs. x _____ hrs./day x _____ days/yr. (Back and forth count as 2)
	Reducer Unit	Motor with brake (Gearmotor with brake) _____ kW (1/ _____ ) Others _____
	Power	_____ V _____ Hz
	Input R.P.M	_____ r/min
	Ambient Temperature	_____ °C
	Equipment Condition	Mounting Location _____ with/without guides
	Dust	Average High with / without bellows Others
	Control Device	Counter LS • Internal LS • Potentiometer • Rotary Encoder • Others K2•K4
Others	Shaft end (B•I•M type end fitting) • Hand wheel • Clevis • Others _____	

Layout Other information

# SAFETY



## Warning Observe the following safety precautions to prevent serious injuries.

- Do not release the brake while jack is loaded. If the brake is released under loaded conditions, suspended objects may fall and lead to accidents.
- Make sure the jack is not loaded when manually operated. Operate jack according to the instruction manual.
- During suspending operations, provide safety guards to prevent load from falling and never stand under the jack.
- Observe the Labor Safety & Hygiene Regulations, General Criteria, Paragraph 1, Chapter 1, Edition 2, or your local regulations.
- Installation, removal, maintenance and inspection:
  - Carry out operation according to the instruction manual.
  - While performing electrical wiring, observe laws and regulations such as Electricity Equipment Criteria and Extension Rules, as well as the cautions (e.g. direction, space, operating conditions, etc.) indicated in the manual. Be especially careful in following the instructions on grounding to prevent electric shocks.
  - Turn off the power and make sure that it does not reconnect accidentally.
  - Wear appropriate clothing and protective gears (safety glasses, gloves, safety shoes, etc.).



## Caution Observe the following safety precautions to prevent accidents.

- Always operate within the allowable stroke range. Operating a jack outside its allowable stroke range may result in accidents.
- Before switching on the jack, make sure the limit switches have been wired correctly and the stroke has been adjusted appropriately.
- The motor must be driven within the correct electrical voltage range to prevent motor burnout or fire.
- Efficiencies of parts may decrease with wear and age. Carry out periodic inspections as set forth in the manual.  
When the parts are no longer functioning or are ineffective, please contact a TSUBAKI E&M distributor for repair.
- Read the manual provided with the product thoroughly before operating and refer to it as necessary. If the instruction manual is misplaced, request a replacement copy from TSUBAKI E&M or your TSUBAKI E&M distributor, indicating the product name, series, and model number.
- The instruction manual must be delivered to the final user.

## Warranty

### 1. Warranty period without charge

18 months effective the date of shipment or 12 months effective the first use of Goods, including installation of Goods to Buyer's equipment or machine - whichever comes first.

### 2. Warranty coverage

Should any damage or problem with the Goods arise within the warranty period, given that the Goods were operated and maintained according to the instructions provided in the manual, Seller will repair and replace at no charge once the Goods are returned to the Seller. This warranty does not cover the following:

- 1) Any costs related to removal of Goods from the Buyer's equipment or machine to repair or replace parts.
- 2) Cost to transport Buyer's equipment or machine to the Buyer's repair shop.
- 3) Costs to reimburse any profit loss due to any repair or damage and other consequential losses caused by the Buyer.

### 3. Warranty with charge

Seller will charge any investigation and repair of Goods caused by:

- 1) Improper installation by failing to follow the instruction manual.
- 2) Insufficient maintenance or improper operation by the Buyer.
- 3) Incorrect installation of Goods to other equipment or machine.

4) Any modifications or alterations of Goods by the Buyer.

5) Any repair by engineers other than the Seller or those designated by the Seller.

6) Operation in an inappropriate environment not specified in the manual.

7) Force Majeure or forces beyond the Seller's control such as natural disasters and injustices done by a third party.

8) Secondary damage or problem incurred by the Buyer's equipment or machine.

9) Defected parts supplied, or specified by the Buyer.

10) Incorrect wiring or parameter setting by the Buyer.

11) The end of life cycle of the Goods under normal usage.

12) Loss or damage not liable to the Seller

### 4. Dispatch service

Service to dispatch a Seller's engineer to investigate, adjust or trial test Seller's Goods is at the Buyer's expense.



**Caution** This catalog does not include operating instructions. Read the actual manual thoroughly before installing or operating the product.



## TSUBAKIMOTO CHAIN CO.

### Headquarters

Nakanoshima Mitsui Building  
3-3-3 Nakanoshima, Kita-ku  
Osaka, 530-0005, Japan  
Phone : +81-6-6441-0011  
URL : <http://tsubakimoto.com>

### Chain & Power Transmission Sales

1-3 Kannabidai 1-chome  
Kyotanabe,  
Kyoto, 610-0380, Japan  
Phone : +81-774-64-5022

### Group companies

#### NORTH and SOUTH AMERICA

**U.S. TSUBAKI POWER TRANSMISSION, LLC**  
301 E. Marquardt Drive, Wheeling, IL 60090, U.S.A.  
Phone : +1-847-459-9500  
URL : <http://www.ustsubaki.com>

**TSUBAKI of CANADA LIMITED**  
1630 Drew Road, Mississauga, Ontario, L5S 1J6, Canada  
Phone : +1-905-676-0400  
URL : <http://tsubaki.ca>

**TSUBAKI BRASIL EQUIPAMENTOS INDUSTRIAIS LTDA.**  
R. Pamplona, 1018, CJ. 73/74, Jd. Paulista  
CEP 01405-001, São Paulo, S.P. Brazil  
Phone : +55-11-3253-5656  
URL : <http://tsubaki.ind.br>

#### EUROPE

**TSUBAKIMOTO EUROPE B.V.**  
Aventurijn 1200, 3316 LB Dordrecht, The Netherlands  
Phone : +31-78-620-4000  
URL : <http://tsubaki.eu>

**TSUBAKIMOTO U.K. LTD**  
Osier Drive, Sherwood Park, Annesley, Nottingham  
NG15 0DX, United Kingdom  
Phone : +44-1623-688-700  
URL : <http://tsubaki.eu>

**TSUBAKI DEUTSCHLAND GmbH**  
ASTO Park Oberpfaffenhofen, Friedrichshafener Straße 1  
D-82205, Gilching, Germany  
Phone : +49-8105-7307100  
URL : <http://tsubaki.eu>

**OOO "TSUBAKI KABELSCHLEPP"**  
Prospekt Andropova 18, Building 6  
115432 Moscow, Russia  
Phone : +7-499-418212  
URL : <http://tsubaki.eu>

#### ASIA and OCEANIA

**TAIWAN TSUBAKIMOTO CO.**  
No. 33, Lane 17, Zhiciang North Road  
Gueishan Township Taoyuan County Taiwan R.O.C.  
Phone : +886-3-3293827/8/9  
URL : <http://tsubakimoto.com.tw>

**TSUBAKIMOTO SINGAPORE PTE. LTD.**  
25 Gul Lane, Jurong, Singapore 629419  
Phone : +65-6861-0422/3/4  
URL : <http://tsubaki.sg>

**TSUBAKI AUSTRALIA PTY. LTD.**  
Unit E, 95-101 Silverwater Road  
Silverwater NSW 2128, Australia  
Phone : +61-02-9704-2500  
URL : <http://tsubaki.com.au>

**TSUBAKIMOTO CHAIN (SHANGHAI) CO. LTD.**  
Room 601, Urban City Centre, 45 Nanchang Road  
Huangpu District, Shanghai 2000020,  
People's Republic of China  
Phone : +86-21-5396-6651/2  
URL : <http://chunben.com>

**TSUBAKIMOTO (THAILAND) CO. LTD.**  
388 Exchange Tower, 19th Floor Unit 1902  
Sukhumvit Road, Klongtoey, Bangkok 10110, Thailand  
Phone : +66-2-262-0667/8/9  
URL : <http://tsubaki.co.th>

**New Zealand Branch**  
Phone : +64-275-082-726

**TSUBAKI INDIA POWER TRANSMISSION PTE. LTD.**  
Chandrika Chambers No.4, 3rd Floor, Anthony Street  
Royapettah, Chennai, Tamil Nadu 600014, India  
Phone : +91-44-4231-5251  
URL : <http://tsubaki.sg>

**PT. TSUBAKI INDONESIA TRADING**  
Wisma 46 - Kota BNI, 24th Floor, Suite 24.15  
Jl. Jend. Sudirman, Kav. 1, Jakarta 10220, Indonesia  
Phone : +62-21-571-4230/31  
URL : <http://tsubaki.sg>

**TSUBAKI POWER TRANSMISSION (MALAYSIA) SDN. BHD.**  
No. 22, Jalan Astaka U8/84A, Bukit Jelutong Industrial Park  
Section U8, 40150 Shah Alam, Selangor, Malaysia  
Phone : +60-3-7859-8585  
URL : <http://tsubaki.sg>

Distributed by: